

Service Manual

Video Projection System

TX-47PT1F

EURO5-VP Chassis



Specifications

Power Source:

220-240V AC, 50Hz

Power Consumption:

239W

Aerial Impedance:

75Ω unbalanced, Coaxial Type

Standby Power Consumption:

1.1W

Receiving System:

PAL-I, B/G, H, D/K, PAL-525/60
 SECAM L/L, B/G, D/K
 M.NTSC
 NTSC (AV only)

Receiving Channels:

UHF E21-E69
 CATV (S01-S05)
 CATV S1-S10 (M1-M10)
 CATV S11-S20 (U1-U10)
 CATV S21-S41 (HYPERBAND)

Intermediate Frequency:

Video	38.9MHz, 34MHz
Sound	32.9MHz, 33.4MHz, 33.16MHz 32.4MHz, 40.4MHz, 33.05MHz 32.66MHz
Colour	34.47MHz (PAL) 34.5MHz, 34.65MHz (SECAM)

Video/Audio Terminals:

AV1 IN	Video (21 pin) Audio (21 pin) RGB (21 pin)	1V p-p 75Ω 500mV rms 10kΩ
AV1 OUT	Video (21 pin) Audio (21 pin)	1V p-p 75Ω 500mV rms 1kΩ
AV2 IN	Video (21 pin) Audio (21 pin) S-Video IN (21 pin)	1V p-p 75Ω 500mV rms 10kΩ Y: 1V p-p 75Ω C: 0.3V p-p 75Ω

AV2 OUT	Video (21 pin) Audio (21 pin) Selectable Output (21 pin)	1V p-p 75Ω 500mV rms 1kΩ
AV3 IN	S-Video IN (4-pin) Audio (RCAX2) Video (RCAX1)	Y: 1V p-p 75Ω C: 0.3V p-p 75Ω 500mV rms 10kΩ
AV4 IN	Video (21 pin) Audio (21 pin) S-Video IN (21 pin)	1V p-p 75Ω 500mV rms 10kΩ Y: 1V p-p 75Ω C: 0.3V p-p 75Ω
AV4 OUT	Video (21 pin) Audio (21 pin)	1V p-p 75Ω 500mV rms 1kΩ
Dolby Surround-Out Rear		6 x Dolby Surround Out RCA

High Voltage:

32kV ± 0.5kV

Projection Tube:

TVVAB10EDZ (B-ASSY)
 TVVAG10EDZ (G-ASSY)
 TVVAR10EDZ (R-ASSY)
 90° Deflection

Audio Output:

(Music Power)	2 x 20W 26W 2 x 16W Impedance 8Ω	Front Left/Right Super 3D Bass Surround
---------------	---	---

Headphones:

Impedance 8Ω

Accessories Supplied:

Remote Control
 2 x R6 (UM3) Batteries

Dimensions:

Height:	1211mm
Width:	1093mm
Depth:	560mm
Net Weight:	61kg

Specifications are subject to change without notice.
 Weights and dimensions shown are approximate.

Panasonic

⚠ WARNING

This service information is designed for experienced repair technicians only and is not designed for use by the general public. It does not contain warnings or cautions to advise non-technical individuals of potential dangers in attempting to service a product. Products powered by electricity should be serviced or repaired only by experienced professional technicians. Any attempt to service or repair the product or products dealt with in this service information by anyone else could result in serious injury or death.

Contents

<input type="checkbox"/> Specifications	Cover
<input type="checkbox"/> Safety Precautions	3
<input type="checkbox"/> Chassis Boards Layout	4
<input type="checkbox"/> Disassembly for Service	5
<input type="checkbox"/> Service Hints	9
<input type="checkbox"/> CRT Set up	12
<input type="checkbox"/> Self Check	14
<input type="checkbox"/> Service Mode Function	15
<input type="checkbox"/> Service Adjustment Procedures	19
<input type="checkbox"/> Digital Convergence	22
<input type="checkbox"/> Location of Lead Wiring	26
<input type="checkbox"/> Conductor Views	29
<input type="checkbox"/> Block Diagrams	40
<input type="checkbox"/> Schematic Diagrams	43
<input type="checkbox"/> Parts Location & Mechanical Replacement Parts List	64
<input type="checkbox"/> Replacement Parts List	66

Safety Precautions

General Guide Lines

1. It is advisable to insert an isolation transformer in the AC supply before servicing a hot chassis.
2. When servicing, observe the original lead dress, especially the lead dress in the high voltage circuits.
If a short circuit is found, replace all parts which have been overheated or damaged by the short circuit.
3. After servicing, see to it that all the protective devices such as insulation barriers, insulation papers, shields, and isolation R-C combinations, are properly installed.
4. When the receiver is not be used for a long period of time, unplug the power cord from the AC outlet.
5. Potential, as high as 32.5 kV, is present when this monitor is in operation. Operation of the Projection Monitor without the rear cover involves the danger of a shock hazard from the power supply. Servicing should not be attempted by anyone who is not thoroughly familiar with the precautions necessary when working on high voltage equipment. Always discharge the anode of the projection tube to the Projection Monitor chassis before handling the tube.
6. After servicing make the following leakage current checks to prevent the customer from being exposed to shock hazards.

Leakage Current Cold Check

1. Unplug the AC cord and connect a jumper between the two prongs on the plug.
2. Turn on the Projection Monitor's power switch.
3. Measure the resistance value, with an ohmmeter, between the jumpered AC plug and each exposed metallic cabinet part on the projection monitor, such as screw heads, connectors, control shafts, etc. When the exposed metallic part has a return path to the chassis, the reading should be between 4 M Ω and 20 M Ω .
When the exposed metal does not have a return path to the chassis, the reading must be ∞ .

Leakage Current Hot Check (See Fig.1)

1. Plug the AC cord directly into the AC outlet. Do not use an isolation transformer for this check.
2. Connect a 2k Ω , 10W resistor, in series with an exposed metallic part on the projection monitor and an earth such as a water pipe.
3. Use an AC voltmeter, with high impedance type, to measure the potential across the resistor.
4. Check each exposed metallic part, and measure the voltage at each point.

5. Reverse the AC plug in the AC outlet and repeat each of the above measurements.
6. The potential at any point should not exceed 1.0V rms. In case a measurement is outside of the limits specified, there is a possibility of a shock hazard, and the projection monitor should be repaired and rechecked before it is returned to the customer.

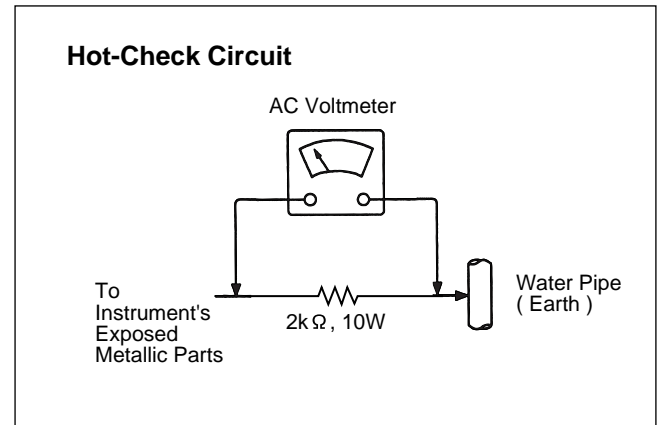

Fig. 1

X-Radiation

Warning :

1. The potential sources of X-Radiation in projection monitor are the High Voltage section and the projection tube.
2. When using a projection tube test jig for service, ensure that jig is capable of handling 32.5kV without causing X-Radiation.

Note: It is important to use an accurate periodically calibrated high voltage meter.

1. Set the brightness to minimum.
2. Set the service switch to the service position.
3. Measure the High Voltage. The meter reading should indicate 31.5 (± 1.0) kV. If the meter indication is out of tolerance, immediate service and correction is required to prevent the possibility of premature component failure.
4. To prevent an X-Radiation possibility, it is essential to use the specified projection tube.

Chassis Board Layout

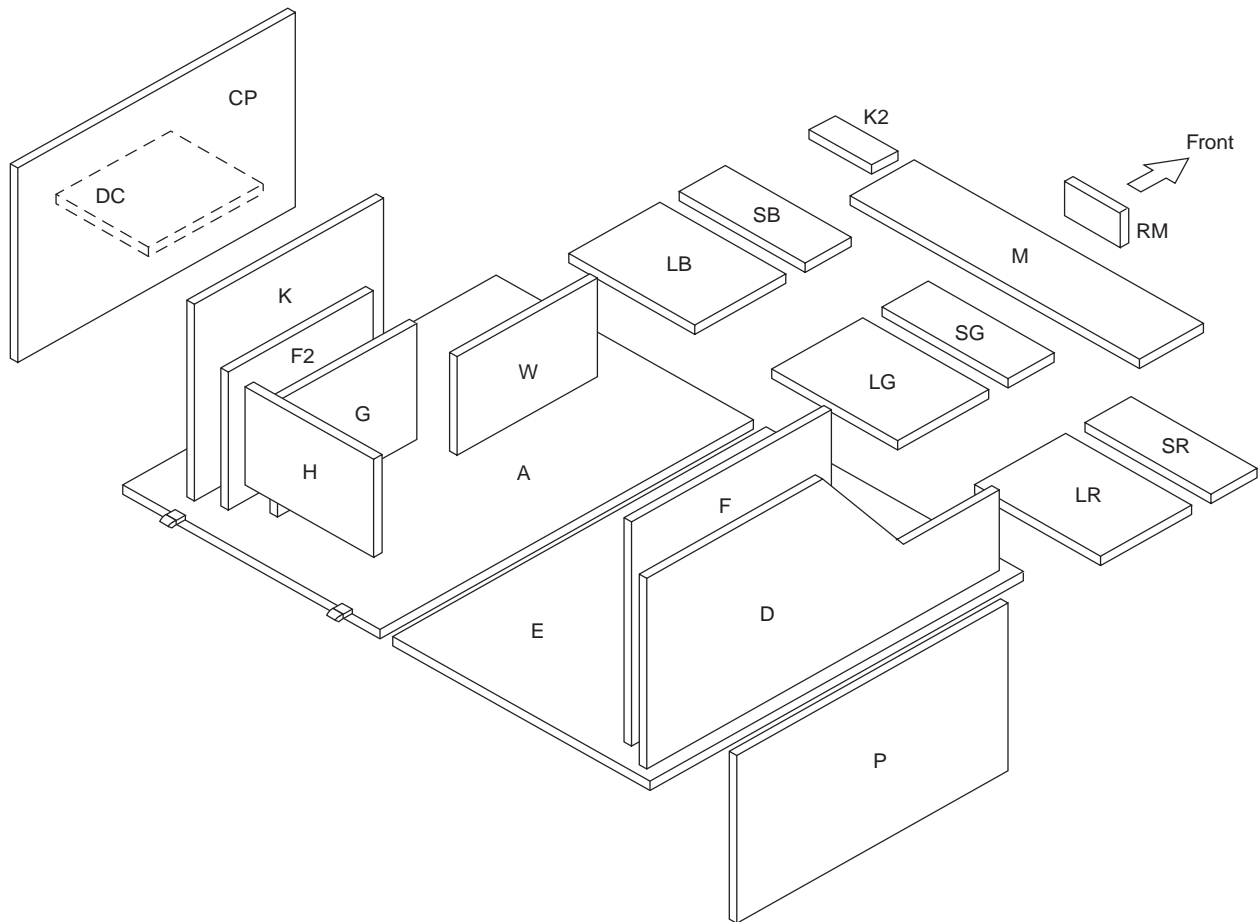

Boad-Name	Function
A-Board	Main Signal, MPU, Audio Output
D-Board	Main Power
P-Board	Remocon Power, Line Filter
M-Board	Control Panel, Front Input, AC Switch
K2-Board	LED Drive
RM-Board	Remote Receiver
E-Board	Horizontal Deflection, High Voltage
F-Board	Jungle, Vertical Deflection
CP-Board	Converter Output, Converter Power
DC-Board	Digital Converter
W-Board	White Balance
LR-Board	CRT Drive (R)
LG-Board	CRT Drive (G)
LB-Board	CRT Drive (B)
SG-Board	VM Output (G)
SR-Board	VM Output (R)
SB-Board	VM Output (B)
F2-Board	Digital Core
K-Board	Dolby Output, Dolby Power
G-Board	PINP, Dolby Signal Process
H-Board	Rear terminal

Disassembly for Service

This flowchart indicates disassembly items of the cabinet parts and circuit boards in order to find the items necessary for servicing, when reassembling, perform the procedures in the reverse order.

Disassembly Flowchart

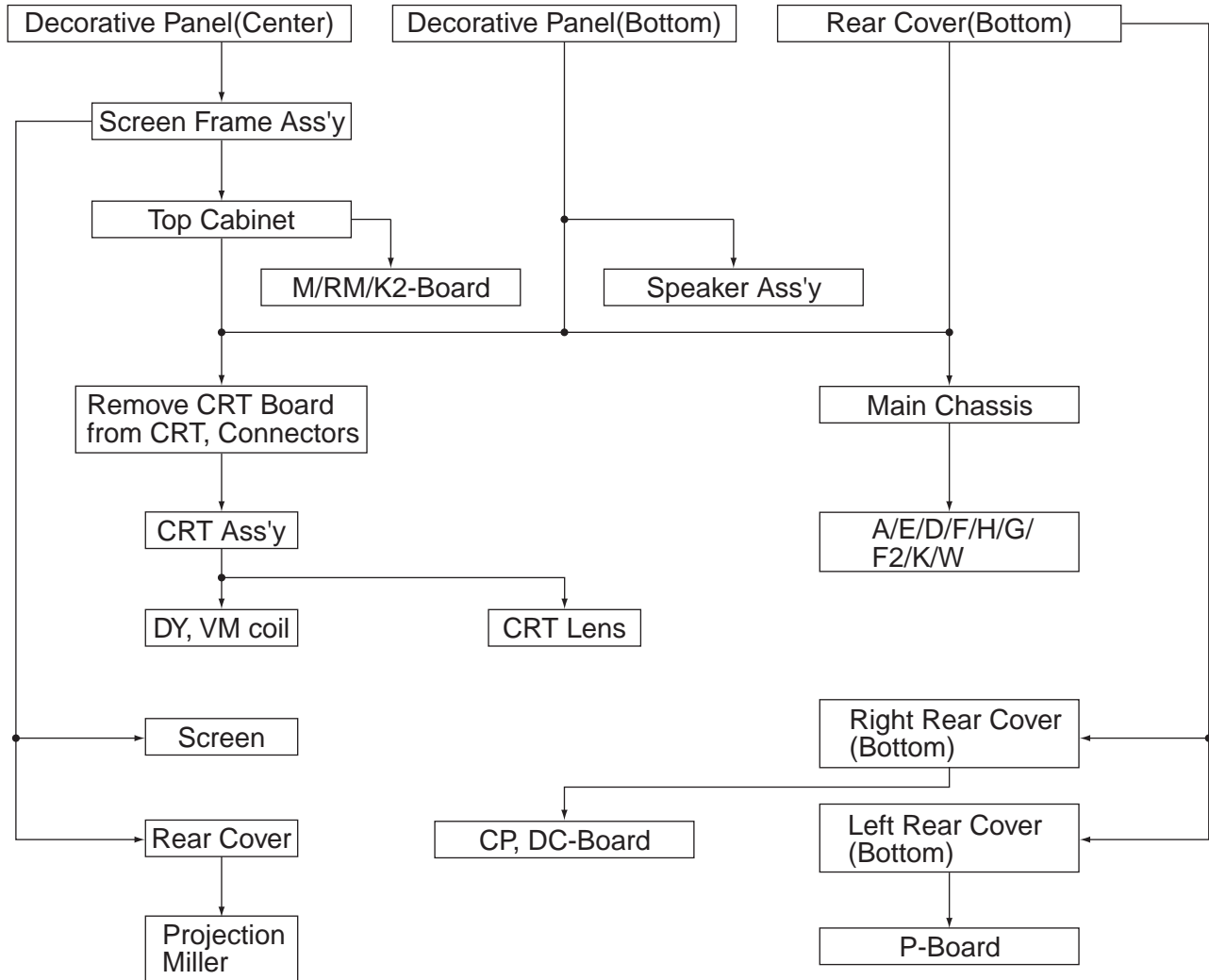

TX-47PT1F

Note: Board ground wires may have to be disconnected to disassemble some boards. All ground wires must be reconnected using jumper leads if necessary before power is applied to Receiver for service.

Front Decorative Panel (Bottom)

1. The front decorative panel is secured by (2) screws.

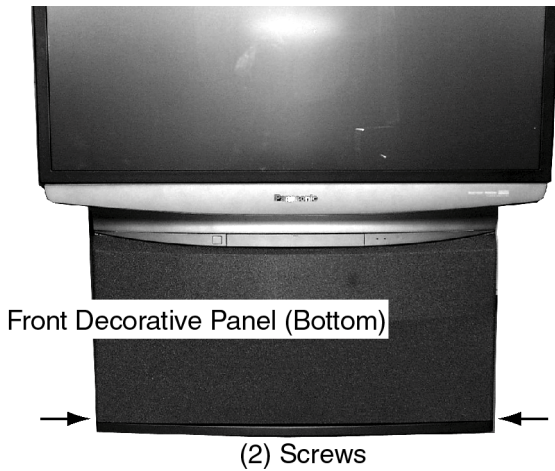

3. Remove (4) screws which secured the Screen Frame Ass'y.
4. Grasp the Screen Frame Ass'y on the sides at the bottom. Pull out on bottom, push up the Screen Frame Ass'y then pull out top edge.

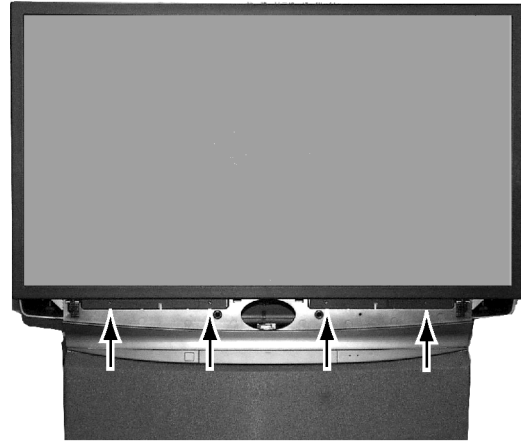

Screen Frame Ass'y

1. Remove (5) screws around rear cover's perimeter.

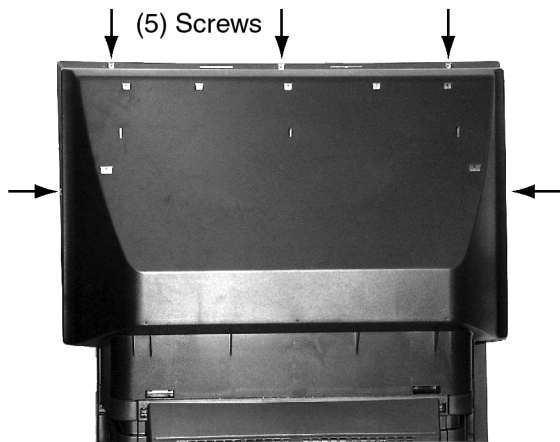

Screen

1. Place frame face down on soft surface.
2. Remove (10) screws.
3. Remove (5) screen fixing Metals.

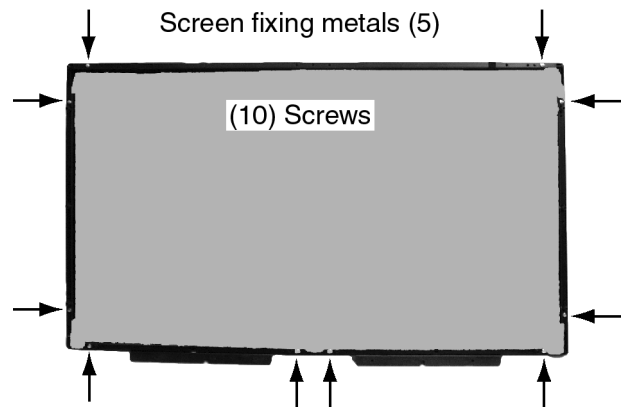

2. The Center Decorative Panel is secured by (4) striker pins. Grip the Center Decorative Panel at the side corner pull to remove.

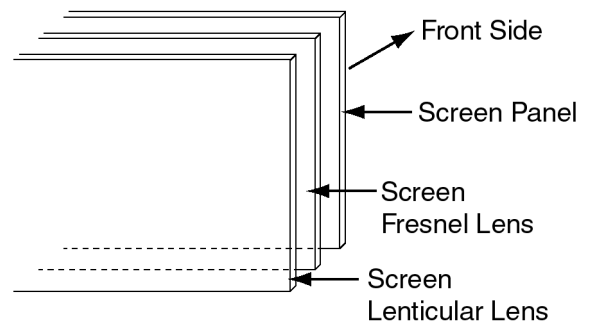
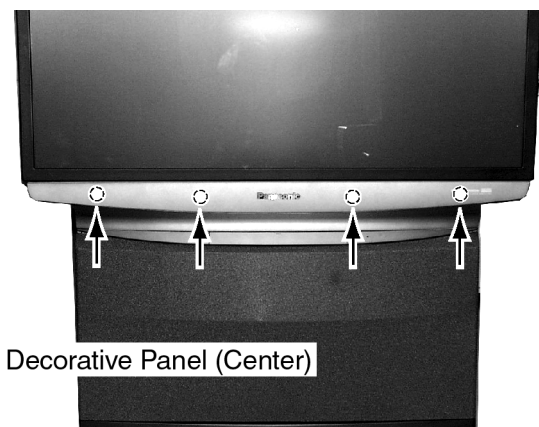

Top Cabinet Ass'y

1. Remove the Screen Frame Ass'y.
2. Remove (2) screws on the Top Rear Cover.



4. Hold the Top Cabinet Ass'y and pull out at the bottom.

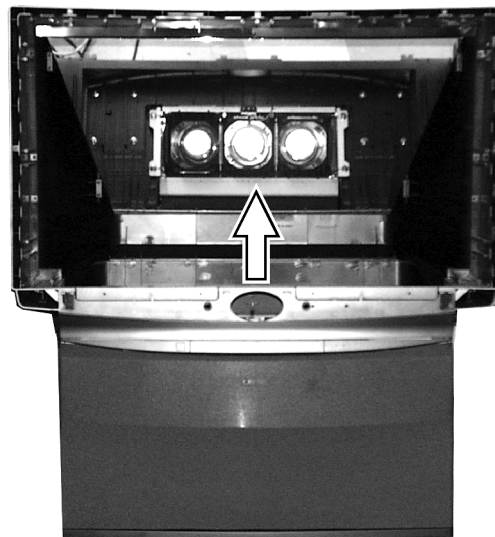

3. Remove the Top Cabinet by removing (8) screws which secured with the Bottom Cabinet Ass'y.

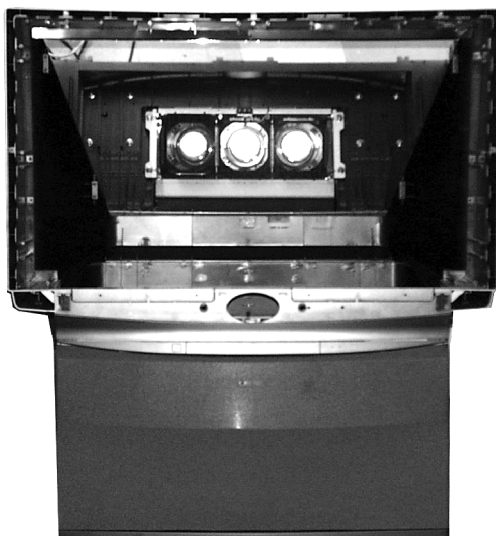

Speaker Units

1. Remove bottom decorative panel located under control panel.
2. Each Left and Right speaker is secured to the cabinet with (3) screws for each bracket.
3. Disconnect the R & L speaker lead connectors from the speaker units.

Top Rear Cover

1. Remove the Screen Frame.
2. Remove (2) screws.

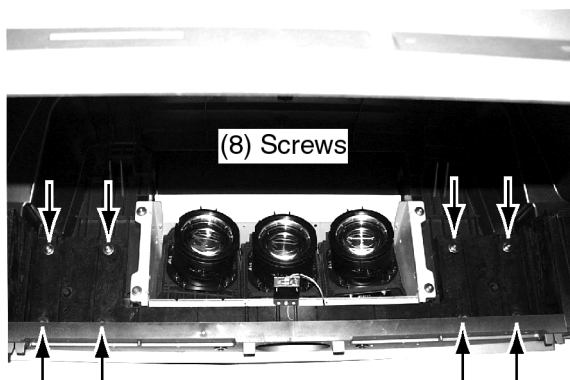

TX-47PT1F

Top Rear Cover (Continued)

3. Remove (10) screws around its perimeter.
4. Slide Bottom Cover up and pull out at the bottom.

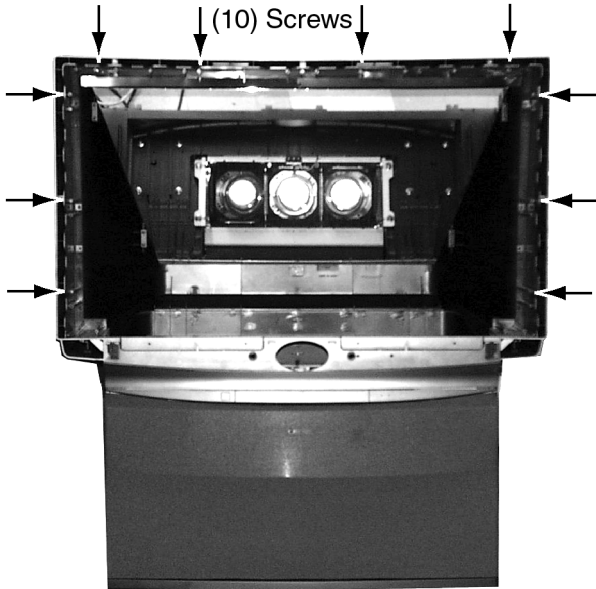

Back Left & Right Bottom Cover

1. The Left Bottom Cover is secured with (7) screws around its perimeter.
2. The Right Bottom Cover is secured with (7) screws around its perimeter.

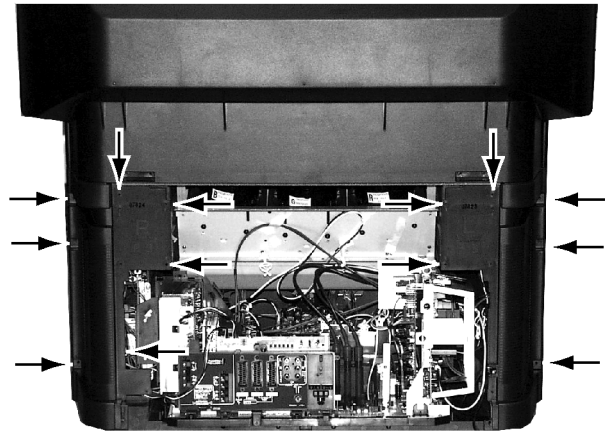

Right Bottom Cover
(7) Screws

Left Bottom Cover
(7) Screws

Bottom Back Cover Ass'y

1. Remove (11) screws around its perimeter.

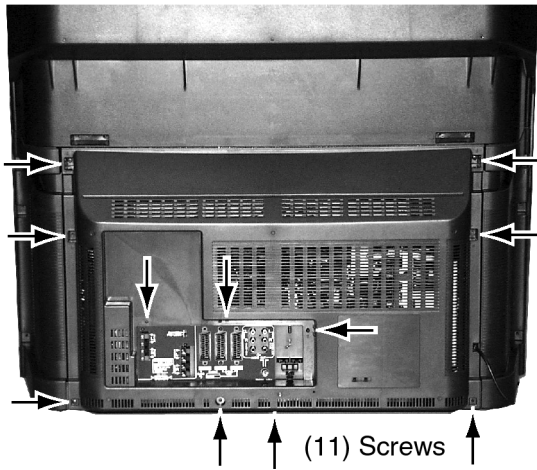

Service Hints

Service position for Main chassis

1. Remove the Bottom Rear Cover by removing (11) screws around its perimeter.
2. Remove lead wires and bundles from holders as necessary.
3. Pull out main chassis and stand it.

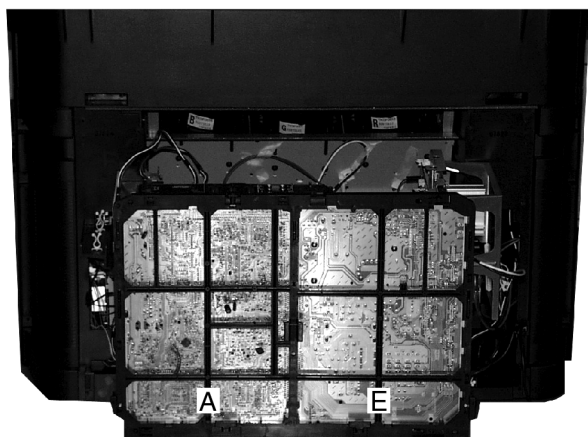

Main chassis

Service Position for CP, DC-Board

1. Remove the Bottom Rear Cover by removing (11) screws around its perimeter.
2. Remove the Right Bottom Cover secured with (7) screws around its perimeter.
3. Remove (2) screws secured the CP and DC Board.
4. Pull out the CP and DC Board.

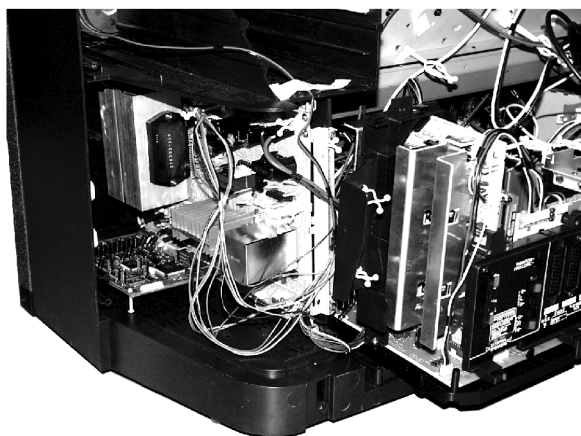

Service Position for D/F/W/G/F2/K-Board

1. Remove the each circuit board from A or E-Board.
2. Connect extension cables between individual circuit board and A or E-Board.

Note: Extension cable kit is supplied as service fixtures and tools. (Part No. TZS709010)

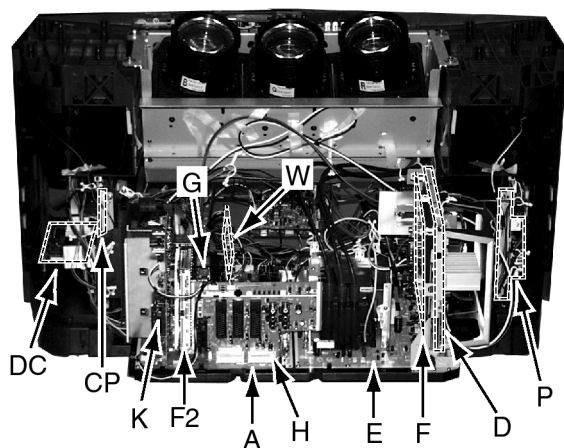

Service Position for P-Board

1. Remove the Bottom Rear Cover by removing (11) screws around its perimeter.
2. Remove the Left Bottom Cover secured with (7) screws around its perimeter.
3. Remove (2) screws secured the P Board.
4. Pull out the P Board.

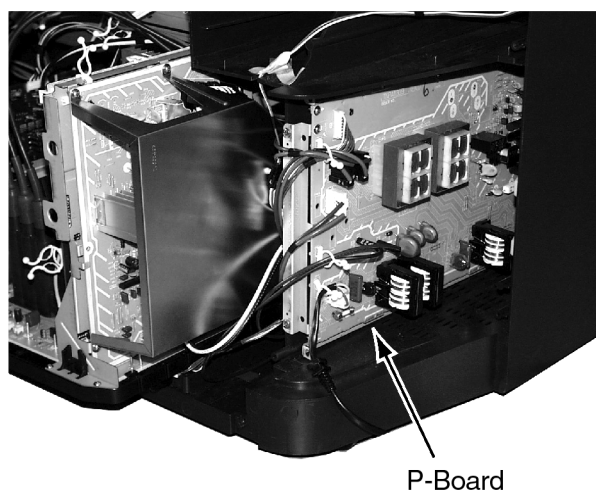

P-Board

TX-47PT1F

Service Position for M/K2/RM-Boards

1. Remove the Top Cabinet Ass'y.
2. Remove M-Board by removing (3) screws.
3. Remove K2-Board by removing (2) screws.
4. Remove RM-Board by removing a screw.

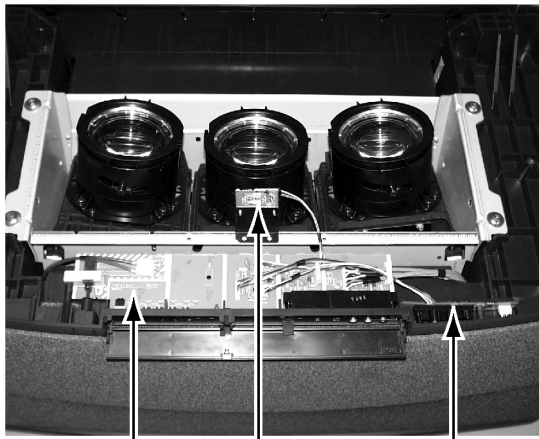

G-Board (3) Screws RM-Board (1) Screw K-Board (2) Screws

Disassembly For CRT Removal

To facilitate CRT replacement, the complete CRT mounting chassis does not need to be removed.

1. Remove the Screen Frame Ass'y, Decorative Panel and the Bottom Rear Cover Ass'y. (See Disassemble for Service).

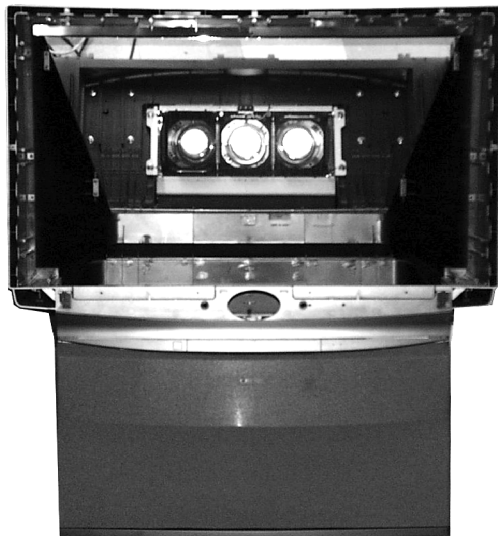

2. From the Rear side, remove the defective CRT's anode lead from the Flyback Transformer block that is mounted secured to the Main chassis E-Board.

3. Grasp the anode lead protective cap body inside, and rotate 1/4 turn counter clockwise and pull anode lead sleeve out of the distributor.
4. **Discharge anode lead to CRT chassis metal frame.**

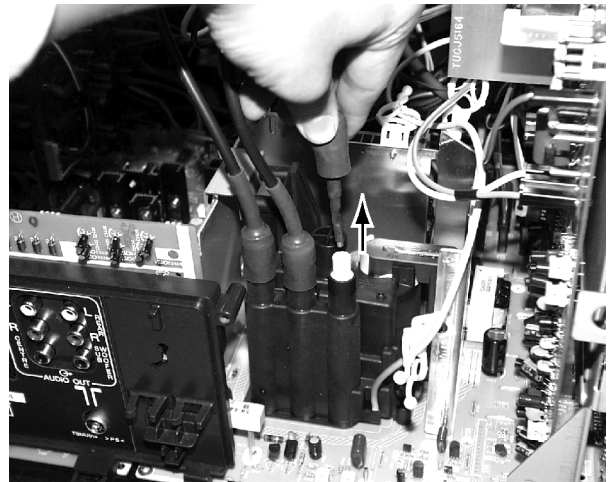

5. Unplug the defective CRT Dag (GND), from the CRT Board, LBGND for LB, LGGND for LG, LRGND for LR.
6. Remove lead wires (DY, VM coil) and anode lead wire from holders as necessary.
7. Remove the CRT Board from the defective CRT neck.
8. Loosen a screw that secured the VM Coil and remove SR/SG/SB Board from CRT neck.
9. Note position of yoke with centering tabs and remove from defective CRT.
10. Remove (4) screws from the defective CRT housing.
CAUTION: Do not remove the 4 CRT lens screws.
11. From the Rear side of the optical block, remove (2) screws from the defective CRT.

(2) Screws (for fixing CRT) x 3

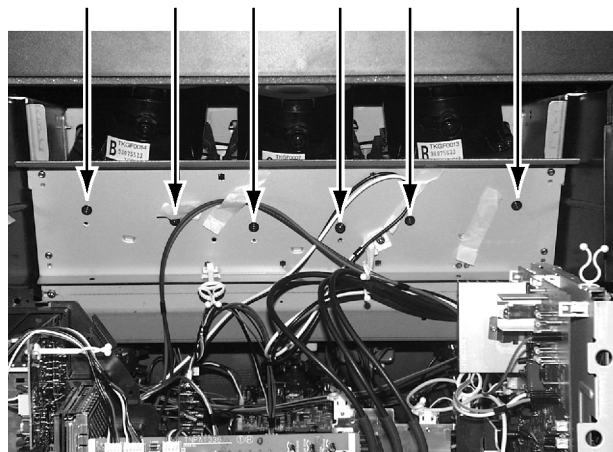

12. From the Top, remove (2) screws from the defective CRT.

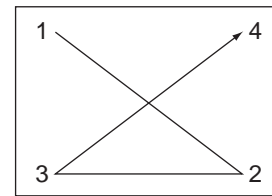
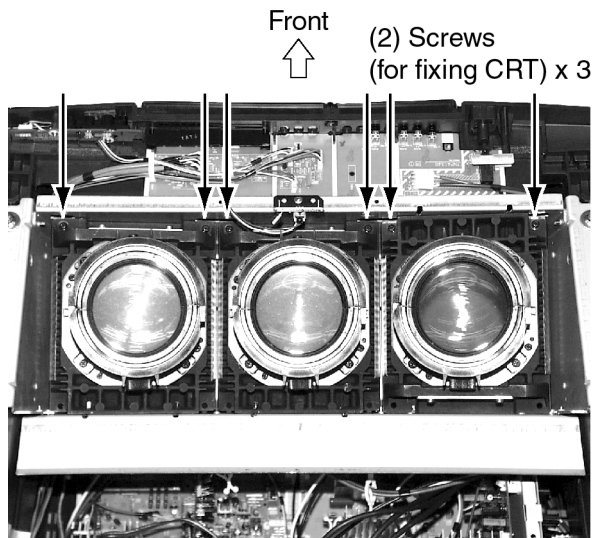

Note: Please assemble with screws in the order shown in detail and tighten with same torque.

13. Release CRT anode lead from CRT chassis wire clamp and all other wires from holders.
14. Wire the anode lead wire.
15. Lift out CRT assembly with lens assembly and other CRT neck assemblies.
16. Lay CRT face down on a soft cloth.
17. Remove CRT lens by removing (4) screws.

(4) Screws (for fixing CRT)

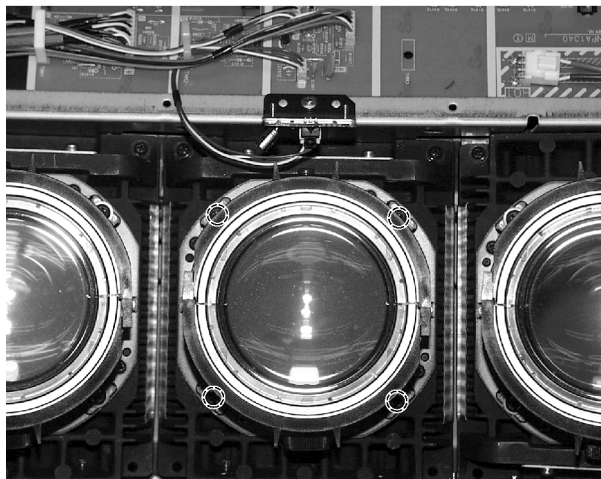

18. Install yoke and VM coil with other CRT neck assemblies on CRT neck in the same order and position as removed from the defective CRT.
19. Push yoke against bell of CRT and tighten the clamp just snug enough so it will not easily shift.
20. Assemble CRT focus lens assembly to new CRT with (4) screws. Make sure focus lens adjustment nut is in the same location as on other CRT focus lens.

CRT Set Up

Caution: Insure yoke plugs on the A-Board are reconnected before turning the Receiver ON to prevent damage to the horizontal output transistor and/or CRTs.

1. Connect test generator to the antenna terminal and set for a monoscope pattern.
2. Loosen yoke clamp, seat yoke against bell of CRT and rotate to correct yoke tile (compare to adjacent CRT). Tighten yoke clamp.
3. Remove adhesive from centering tabs and set centering tabs for zero correction. (Fig. 1)

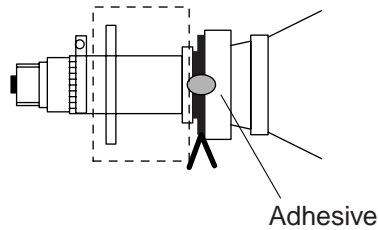

Fig. 1

4. Cover replacement CRT lens and static converge the tubes not replaced, if needed. Check size and linearity of pattern and adjust as required.
5. Uncover replacement CRT lens and cover other two CRT lenses. Adjust electrical and optical focus (lens), if required.
6. Uncover all CRT lenses and use yoke centering magnet to converge replacement CRT (in center area of screen only) with other two CRTs. Disregard non-convergence in areas other than center area.
7. Perform White Balance adjustments.

Dynamic Focus Adjustmenet

1. Focus adjustments should be performed after 1 hour of aging.
2. Use oscilloscope with 100 : 1 probe.
3. Apply monoscope pattern.
4. Adjust the Red, Blue and Green focus VR on the focus block for best focus of overall picture of each CRT. (Fig. 2)

Focus Pack

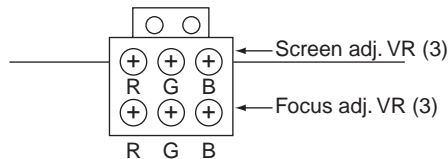

Fig. 2

5. Connect the scope probe to TPF1, GND to TPF2. Scope set at 20V/div & 5m sec/dev.
6. Adjust R741 VR so that waveform (A) is 260V \pm 20V. (Fig. 3)
7. Adjust R726 VR so that waveform (B) is 570V \pm 20V. (Fig. 3)

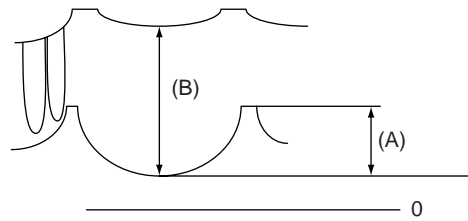

Fig. 3

11. Proceed with Focus Adjustments.

Focus - Electrical Adjustment

1. Cover the Red and Blue CRT, projecting Green only.
The electrical focus controls are located on the front. Adjust the Green Focus VR for best focus of overall picture. (Fig. 2)
2. Repeat for Red focus VR while projecting Red only.
3. Repeat for Blue. (Best focus at bottom left corner of screen)

Focus - Optical Lens Adjustment

Note: This adjustment normally should not require resetting unless the lens has been replaced or adjustment has changed.

1. Optical focus adjustment is located on the top of each CRT lens system. Loosen the adjustment knurled locking knobs. (Fig. 4)

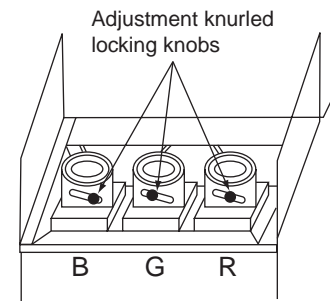

Optical lens focus adjustment

Fig. 4
(Rear view)

2. Turn the Receiver ON apply and view a monoscope pattern.
3. Adjust each lens focus for best focus while viewing each CRT.
4. Cover the Red and Blue CRT, projecting green only. Rotate the Green lens for best focus around screen center area.
5. Do the same for the Red focus lens while projecting Red only.
6. Repeat for Blue.

Horizontal Phase Adjustment

1. Set the Aspect to 16:9.
 2. Set the receiver to Static Convergence mode.
 3. Apply a monoscope pattern.
 4. Press "HELP" key on the remote control so that only the green lens is projecting the monoscope pattern.
 5. In serviceman adjustment mode select the static convergence menu. Adjust all horizontal and vertical RGB data (GV, GH, RV, RH, BV, BH to 0).
 6. Cancel the P-Convergence data.
 7. Set the V-pos data to 41.
 8. Loosen the deflection coil screw on the Green CRT.
 9. Adjust the Green monoscope pattern to be equal on left and right with the grid horizontal center line. Also adjust for horizontal and vertical tilt.
- Note:** Push deflection coil to top of CRT neck, then tighten deflection screw after adjusting each CRT centering and Tilt.
10. Press "HELP" key on the remote control to project Blue only.
 11. Using the red deflection coil, adjust the Blue monoscope pattern center to be the correct mm left from the center of the green monoscope. (see Fig. 5)

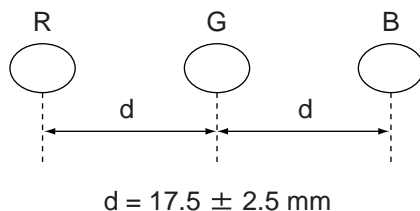

Fig. 5

12. Press "HELP" key on the remote control to project Red only.
13. Using the Blue deflection coil adjust the Red monoscope pattern center to be the correct mm. Right from the center of the Green cross hatch (see Fig. 6).
14. Transfer lens cap to project green.
15. Press remote control TV/Video key 3 times to display the "OSD Pos ADJ" mode.
16. Adjust the "+" position of OSD to be a center of pattern by pressing "CH" keys or "VOL" keys on remote control.
17. Press "SET UP" key on remote control then "N" key.

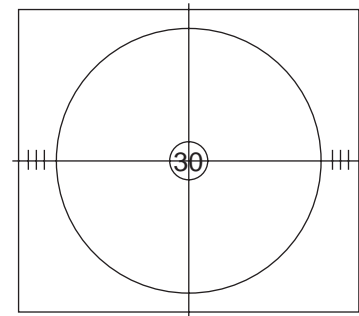



Fig. 6

18. Press "Power" key on remote control then "N" key to exit Digital Convergence adjustment mode.
19. Make sure that all deflection coils are pushed completely toward the CRT cones and that all screws are tightened after each adjustment.

TX-47PT1F

Self Check

1. Self-Check is used to automatically check the bus lines and hexadecimal code of the TV set.
2. To get into the Self -Check mode press the down (-/v) button on the customer controls at the front of the set, at the same time pressing the **STATUS** button  on the remote control, and the screen will show :

VPC	:	O.K.	PCB	:	O.K.
AN5	:	O.K.	Cab	:	O.K.
TUN	:	O.K.	Sum	:	XXXX
E2	:	O.K.			
MSP	:	O.K.	OPTION1	:	B9
DPL	:	O.K.	OPTION2	:	FD
CXA	:	O.K.	OPTION3	:	1F
WB	:	O.K.	OPTION4	:	0D
CI1	:	O.K.	OPTION5	:	FB
CI2	:	O.K.	OPTION6	:	63
VP	:	O.K.			
DFU	:	O.K.			
COL	:	O.K.			
DIP	:	O.K.			
DIS	:	O.K.			
CNV	:	O.K.			

If the CCU ports have been checked and found to be incorrect or not located then " - - " will appear in place of "O.K." .

Service Mode Function

MPU controls the functions switching for each IICs through IIC bus in this chassis. The following setting and adjustment can be adjusted by remote control in Service Mode.

How to enter SERVICE 1

1. In sound menu, set BASS to MAX, and set TREBLE to MINIMUM.
2. Simultaneously press INDEX button on remote control and VOLUME DOWN button [-] on the TV set.

How to enter SERVICE 2

1. Select SUB-BRIGHTNESS in service 1 mode.
2. Set the channel to CH99.
3. Press HOLD button on remote control.

Note: To exit to Service mode, press N button on remote control.

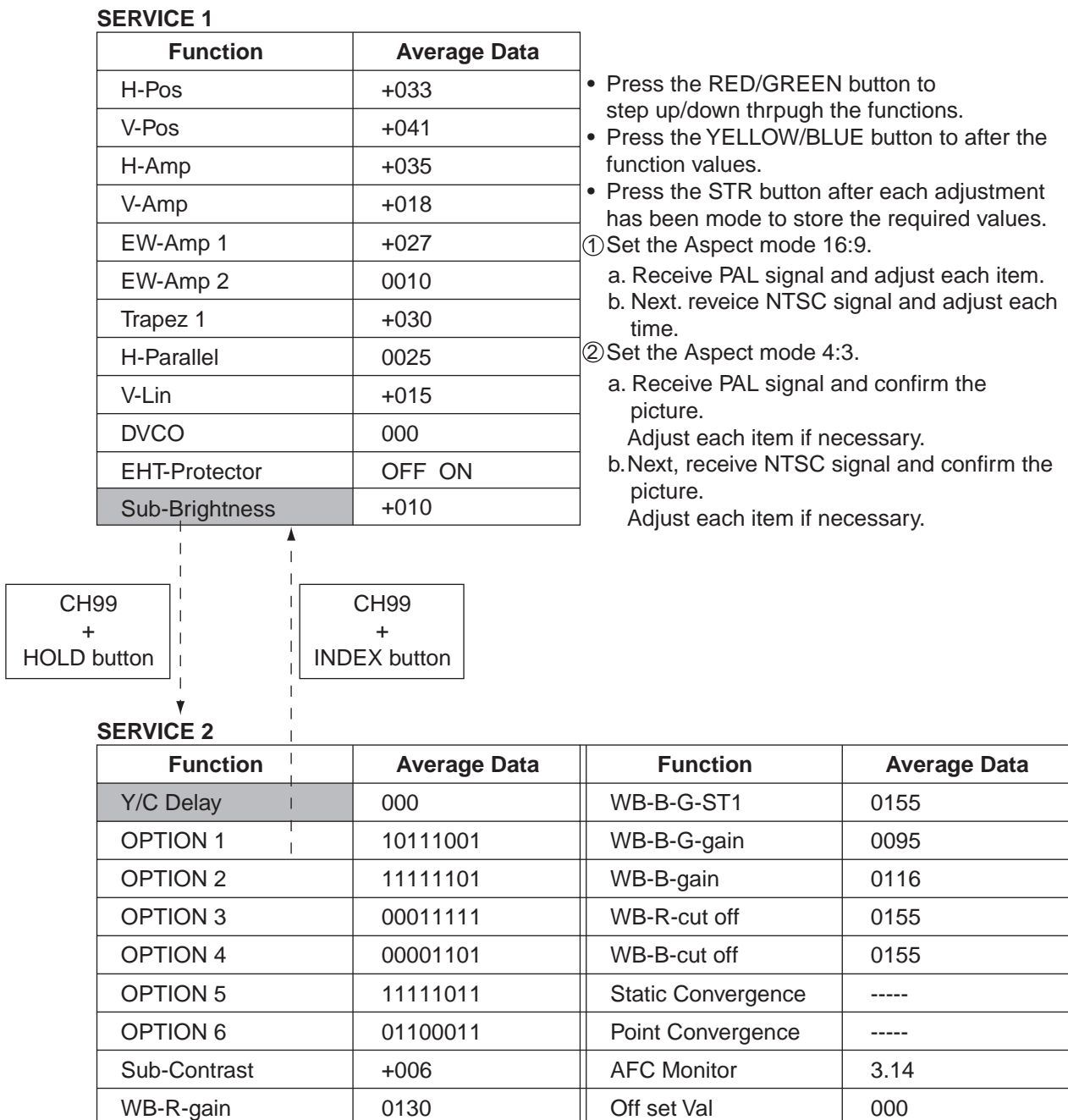

TX-47PT1F**Option Description**

Option 1		Description		
Bit No.	Data			
0	1	Colour System	0 0	Audio Only
1	0		0 1	Auto(PAL/SECAM/NTSC)
			1 0	Auto(PAL/NTSC)
2	0	TV System	0 0	I
3	1		0 1	B/G
			1 0	I, B/G, D/K, L/L
			1 1	B/G, D/K
4	1	Hyper Channel Selection	0	UHF only
			1	UHF/VHF
5	1	Fine Tune	0	Disable
			1	Enable
6	0	Tuner Select	0	Maco
			1	Alps
7	1	Not Used		

Option 2		Description		
Bit No.	Data			
0	1	CRT Size	0	4:3
			1	16:9
1	1	21" CRT	0	Disable
			1	Enable
2	1	Channel BLanking	0	Disable
			1	Enable
3	1	AV Blanking	0	Disable
			1	Enable
4	1	Comb Filter	0	Disable
			1	Enable
5	1	Geomagnetic Correction	0	Disable
			1	Enable
6	1	Auto Aspect	0	Auto Wide only in Auto Aspect
			1	Auto Wide Always Active
7	1	PIP	0	Disable
			1	Enable

Option 3		Description	
Bit No.	Data		
0	1	MPX Display	0 Nicam 1 MPX
1	1	Nicam	0 Disable 1 Enable
2	1	A2 Stereo	0 Disable 1 Enable
3	1	Volume Correction	0 Disable 1 Enable
4	1	Sound AI	0 Disable 1 Enable
5	0	Loudness	0 Disable 1 Enable
6	0	Graphic Equaliser	0 Disable 1 Enable
7	0	Not Used	

Option 4		Description	
Bit No.	Data		
0	1	Dolby	0 Disable 1 Enable
1	0	3D Active (Two Speaker Dolby sets)	0 Disable 1 Enable
2	1	Export Dolby	0 Disable 1 Enable
3	1	3D Woofer	0 Disable 1 Enable
4	0	External Sub-Woofer	0 Disable 1 Enable
5	0	Not Used	
6	0	Not Used	
7	0	Not Used	

Option 5		Description		
Bit No.	Data			
0	1	FLOF Text	0 1	Disable Enable
1	1	TOP Text	0 1	Disable Enable
2	0	Text language	0 1	Western Eastern
3	1	OSD language	0 1	English Multipul
4	1	AV3S	0 1	Disable Enable
5	1	AV3	0 1	Disable Enable
6	1	Power On EC Mode	0 1	Disable Enable
7	1	Q Link	0 1	Disable Enable

Option 6		Description		
Bit No.	Data			
0	1	Child Lock	0 1	Disable Enable
1	1	German TV	0 1	Disable Enable
2	0	French TV	0 1	Disable Enable
3	1	U.K. TV	0 1	Disable Enable
4	1	Irish TV	0 1	Disable Enable
5	1	B.S. Safety Check	0 1	Disable Enable
6	1	OSD Draw	0 1	Disable Enable
7	1	RGB Display	0 1	Disable Enable

Service Adjustment Procedures

Item / preparation	Adjustment Procedure
<p><u>+B Voltage Confirmation</u></p> <p>1. Operate the set.</p> <p>2. Set controls :</p> <p style="padding-left: 20px;">Bright minimum</p> <p style="padding-left: 20px;">Contrast minimum</p> <p style="padding-left: 20px;">Volume minimum</p>	<p>Confirm the following voltages.</p> <p>1. Pin 1 of connector D3 : 207.0 ± 3.0V</p> <p>2. Pin 4 of connector D11 : 130.0 ± 2.0V</p> <p>3. Pin 8 of connector D11 : 26.0 ± 2.0V</p> <p>4. Pin 1 of connector D13 : 15.5 ± 1.5V</p> <p>5. Pin 5 of connector D13 : 15.5 ± 1.5V</p> <p>6. Pin 1 of connector D11 : 9.0 ± 1.5V</p> <p>7. Pin 7 of connector D3 : 6.4 ± 0.24V</p> <p>8. Pin 8 of connector D13 : -15.5 ± 1.5V</p> <p>9. Pin 3 of connector D3 : 12.0 ± 0.5V</p> <p>10. Pin 1 of connector D14 : 40.0 ± 2.0V (open) 32.0 ± 2.0V (short)</p>
<p><u>High Voltage</u></p> <p>1. Remove Red CRT anode lead from Distributor by grasping anode lead protective cap top and squeeze it against the locking cap body under the protective cap. Rotate 1/4 turn and pull anode lead sleeve out of distributor connector. Discharge anode lead to CRT metal chassis. :</p>	<p>1. Receive a PAL monoscope pattern Signal.</p> <p>2. Confirm that high voltage is 32.0 (+0.1, -0.3) kV.</p>

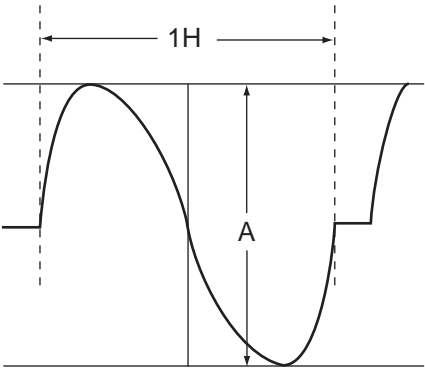
Item / Preparation	Adjustment Procedure	Waveform
<p><u>Shading</u></p> <p>1. Confirm that FOCUS Adjustment was performed.</p> <p>2. Connect an oscilloscope to TPW2(GND) on W-Board.</p>	<p>1. Adjust R7892 on W-Board so that the waveform A is 2.7V ± 0.2V p-p</p>	 <p>A = 2.7V ± 0.2V p-p</p>

TX-47PT1F

Sub Contrast, White Balance and Electrical Focus Adjustment

Preparation

- Colour Balance : Normal
- Picture Menu : Normal AI=OFF
- Signal Generator :
 - Crosshatch Pattern
 - Black Pattern

•Sub Contrast Adjustment

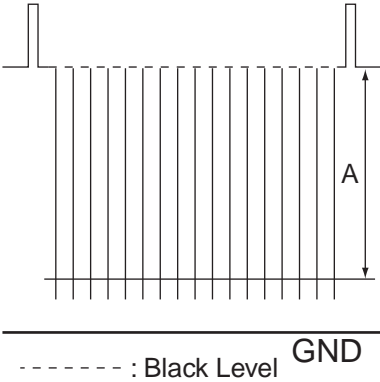
Adjustment Procedure	Waveform
1. Connect Oscilloscope : TPLG1 2. Into Service 2 Sub Contrast 3. Recieve Crosshatch Pattern 4. Adjust Sub Contrast : $A=80 \pm 2V$	 <p>----- : Black Level GND</p>

•CUT OFF Adjustment

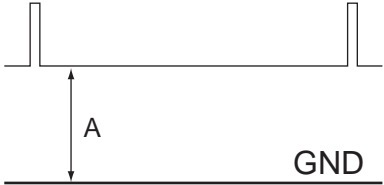
Preparation & ADJ	Adjustment Procedure			Waveform
	Service1	B-CUT OFF3	R-CUT OFF3	
Oscilloscope	TPLG4	TPLB4	TPLR4	Black Pattern  <p>GND</p>
Setting Projector	Into Service mode 2	Into Service mode 2	Into Service mode 2	
Signal generator	Black Pattern	Black Pattern	Black Pattern	
Adjustment	Black Level $A = 200 \pm 2V$	B-CUT OFF3 $A = 185 \pm 2V$	R-CUT OFF3 $A = 185 \pm 2V$	

•White Balance Adjustment

This adjustment requires that the serviceman use skills in observing what a screen without colour should look like.

1. Enter the service mode.
2. Apply a monoscope pattern to one of the video inputs.

•High Light White Balance Adjustment

1. Adjust Red Drive for Red and Blue Drive for Blue adjustment.
2. Make sure the screen is not blue or red.
The screen should be white in all areas.
3. Check the monoscope pattern for a black and white picture with even shades of gray and no colour tint in the picture.

•Low Light White Balance Adjustment

1. Adjust Red cutoff for red and Blue cutoff for blue.
2. Check the screen for even white in all areas, no colour.
3. Check the monoscope pattern for a black and white picture, even shades of gray and no colour tint in the low light areas.
4. Repeat the High Light and Low Light White Balance again until the white balance tracks from high light to low light.

•Colour Check

Again, the serviceman ability to see colour and the balance of colour is important for these adjustments.

Using a clean RF or video signal, set the colour level so that it does not saturate or appear harsh. Make sure that colour is not set so that it appears dull and washed out. Look for natural colours, try to adjust the picture to appear as a normal photograph.

Digital Convergence

The following is a flowchart outlining the procedures for **Digital Convergence**.

KEY OF REMOTE IN DIGITAL CONVERGENCE ADJ. MODE

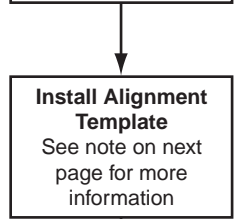
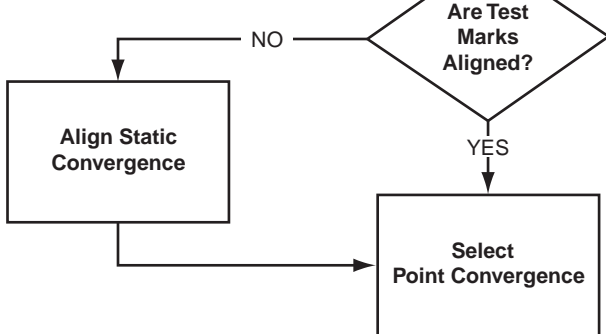
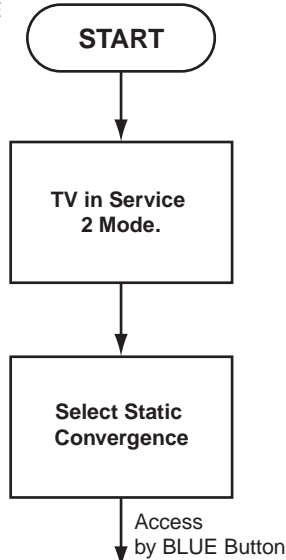
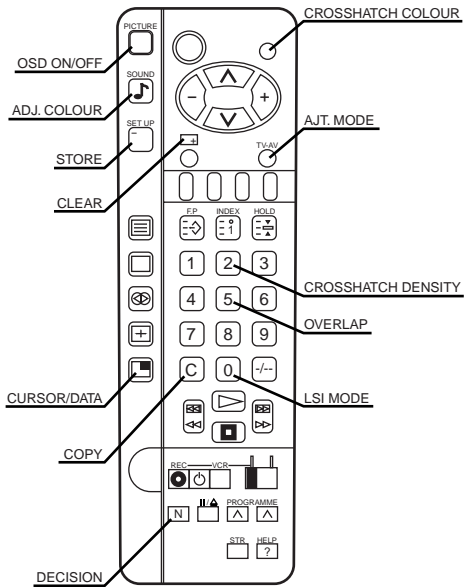

Static Convergence

1. Using the Channel UP/DOWN and Volume LEFT/RIGHT buttons, align the Green Horizontal and Vertical test marks with the Screen Frame mechanical reference marks.
2. Press N button to cycle through options and exit Static Convergence Mode.

- Press **RED/GREEN** button on remote until "Point Convergence" is displayed.
- Press **BLUE** button on remote to enter **Point Convergence Mode**.

Note

When performing a complete convergence alignment, set all data of Static Convergence to 0 (zero). This will create a zero reference when convergence is completed.

Copying Procedures

Point Convergence Mode must be active prior to copying data.

1. Press the Copy Key ("C" on the numeric keypad).
2. Using the **Cursor UP/DOWN** buttons, select the plane that is to be copied. Press Enter key (**N** button).
3. Using the **Cursor UP/DOWN** buttons, select the destination plane. Press Enter key (**N** button).

Helpful Hint

There are four "planes" or storage areas available when adjusting convergence: the Factory Default Plane (P-4/FACT), the Actual Plane (P-1 and P-2), and the Test or Temporary Plane (P-3). **P-4** is the plane that contains the factory baseline and is **only used at the factory**. **P-1** is the plane that is always active during **NTSC**. **P-2** is the plane that is always active during **PAL and SECAM**. **P-3** is a storage bin that can be used to store data safely while P-1 and P-2 is being adjusted. To copy data between the different planes proceed with the steps outlined in the **Copying Procedures**. It is advisable to copy good data from P-1 (or P-2) to P-3 at the start and occasionally during convergence, just in case P-1 (or P-2) gets corrupted during adjustment. Then P-3 can be copied into P-1 (or P-2) and alignment can continue with the uncorrupted data that was last stored.

Digital Convergence (cont.)

Convergence Alignment Template (Parts NO. TZSC07014)

Alignment Template

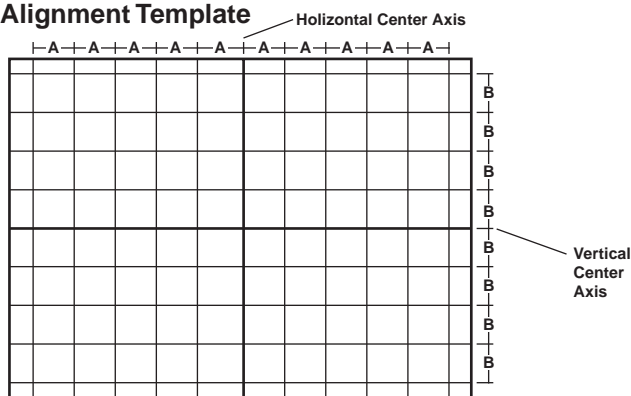

Block Dimensions	
For NTSC	For PAL/SECAM
A=86.02mm	A=87.82mm
B=65.63mm	B=63.81mm

Align the Template's Horizontal and Vertical center lines with the TV's Mechanical Test Marks.

The **Convergence Alignment Template** is a grid approximately the size of the viewing screen used to ensure the proper size and shape of the alignment rasters. It is 10 blocks across by 8 blocks high. The grid dimensions will vary according to the size of the screen.

Apply a Convergence Alignment Template to the viewing screen of the TV. Make sure the center lines are properly aligned. If a template is not available, one can be created by following the instructions below.

Create a Convergence Alignment Template by drawing the pattern to the right in the actual dimensions on transparent film or tracing paper. Start with the Horizontal and Vertical Center Axis and work outwards until the pattern is complete. Pay close attention to the actual dimensions of the pattern.

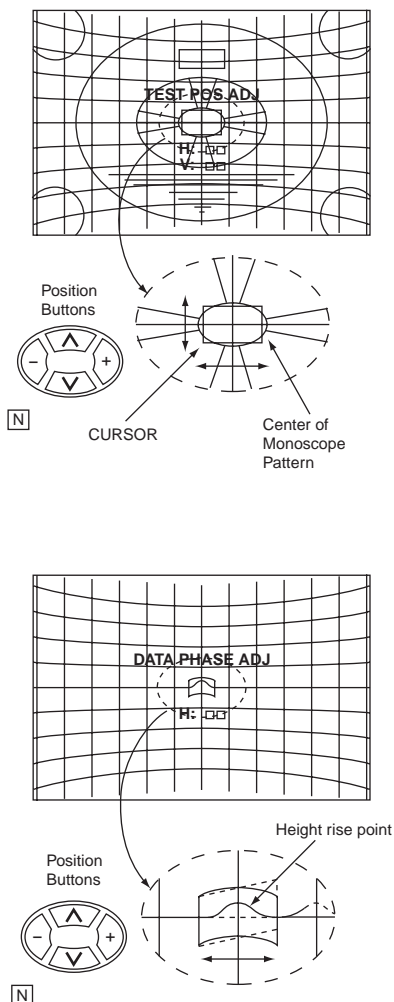

A

Enter "TEST POS ADJ" (LSI MODE)

- Press Initialize (LSI) key (0 button on remote) to enter "TEST POS ADJ" (Test Pattern Phase Adjustment).
- Press Enter key (N button on remote).

Adjust the cursor over the center of a monoscope pattern

- Press the Superimpose key (5 on the remote) to view the injected monoscope pattern.
- Using the Position Keys (Channel UP/DOWN and Volume LEFT/RIGHT), center the cursor over the center of the monoscope pattern.

Enter "DATA PHASE ADJ"

- Press the Superimpose key (5 on the remote) to stop displaying the monoscope pattern.
- Press Mode key (TV/AV button on remote) to cycle through adjustment modes.
- Select "DATA PHASE ADJ" mode

Adjust the Height Rise Point

- Using the Volume LEFT/RIGHT buttons on remote, position the Height Rise Point of the screen center line to the middle of the cursor.
- Press Initialize (LSI) key (0 button on remote) to exit.

B

Digital Convergence (cont.)

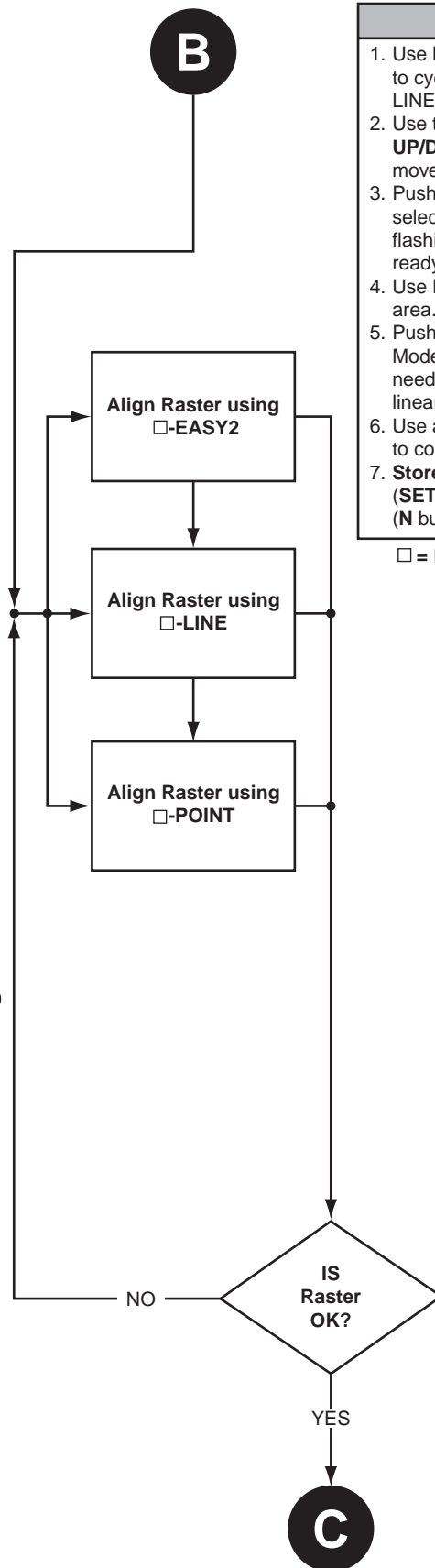
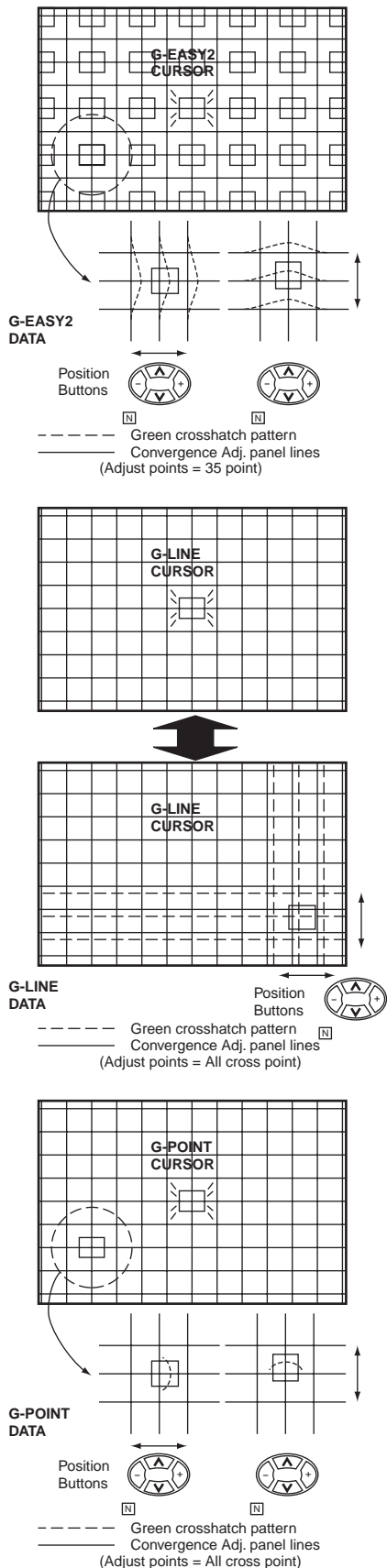

- ### Point Convergence
1. Use Mode Key (TV/AV button on remote) to cycle through adjustment modes: □-LINE, □-EASY2, □-PERI-, □-POINT.
 2. Use the Position Keys (Channel UP/DOWN and Volume LEFT/RIGHT) to move the cursor to the desired area.
 3. Push Data/Cursor Key (PIP button) to select Data Mode. The cursor will stop flashing. This indicates that the system is ready to adjust.
 4. Use Position Keys to adjust the selected area.
 5. Push Data/Cursor key to select Cursor Mode. Repeat steps 2 through 5 as needed to ensure good shape and linearity.
 6. Use any combination of adjustment modes to complete convergence.
 7. **Store Data often**, using the Store Key (SET UP button on remote) and Enter Key (N button).

□ = R (RED), G (GREEN), or B (BLUE)

Digital Convergence (cont.)

Helpful Hint
 The procedures for aligning convergence for each raster mode is identical. First align the Green raster with a Convergence Alignment Template. Then align the Red and the Blue rasters to merge with the Green raster, using the Yellow pattern (for the Red raster), Cyan or White pattern (for the Blue raster). It is highly recommended to store often throughout the convergence procedure.

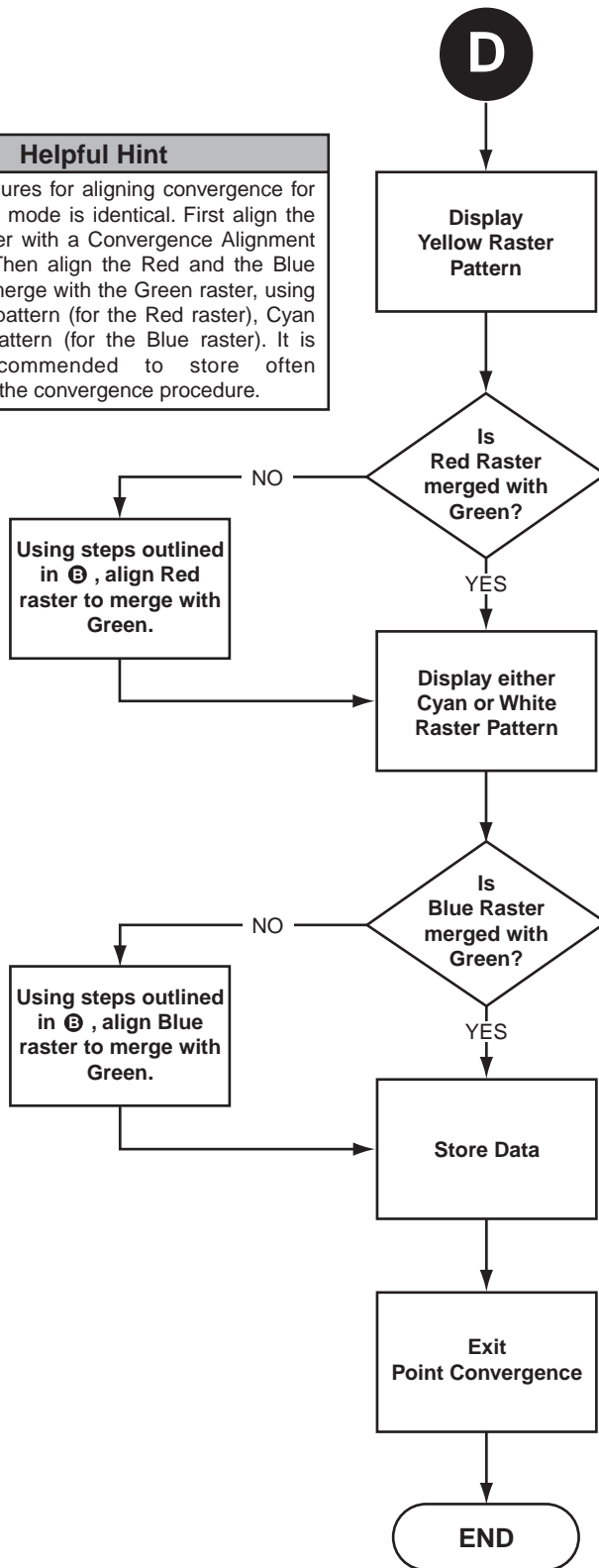

- Press Pattern Keys (MUTE [~~X~~] on remote) as needed to display **Yellow (Red + Green)** raster pattern.

- Press Pattern Keys (MUTE [~~X~~] on remote) as needed to display either the **Cyan (Blue + Green)** or the **White (Red + Green + Blue)** raster pattern.

- Press Store Key (**SET UP** button on remote) to save data in P-1.
- Press Enter Key (**N** button on remote)

- Press Exit Key (**POWER** button on remote)
- Press Enter Key (**N** button on remote)

Reminder
 When completed, if no other alignments are necessary, **exit the Service Mode.**

- Press **N** buttons
- The TV should reset itself and turn itself back on in a few seconds.
- Adjust TV for normal viewing.

Location of Lead Wiring

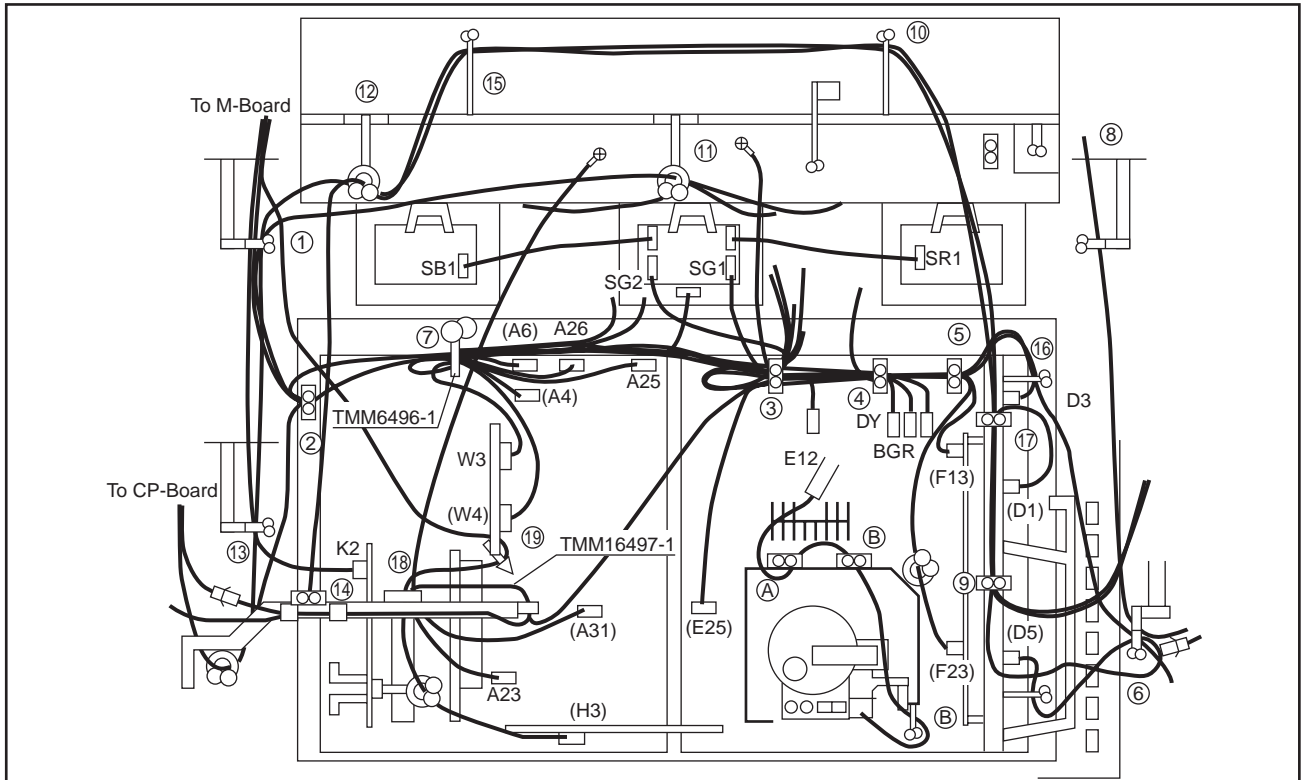

LEAD	CLAMPER																		
	1	2	3	4	5	6	7	8	9	10	11	12	13	14	15	16	17	18	19
M11-A26	●	●					●												
M12-A25	●	●					●												
CP11, 12, 13-CY	●										●		●						
CP8-P4									●	●		●		●	●		●		
CP6-A6, W4		●					●												
CP7-F13		●	●	●	●		●												
M1-P2						●		●											
D5-K2	●					●			●	●		●	●		●		●		
W3-LG1, LB2							●												
W3-LR2			●				●												
A4-SG2		●					○												
E12-LG11			○				○												
DY (R, G, B)			○	●												●			
E25-P24			●	●	●	●										●			
D4-P11							●									●			
D3-LG2, LG3			○	●	●											●			
D2-SG1			●	●	●													●	●
M12-A23																		●	
D1-P3									●							●			
P21-Bottom Optical Plate			●	●	●	●												●	
A31-Bottom Optical Plate																			

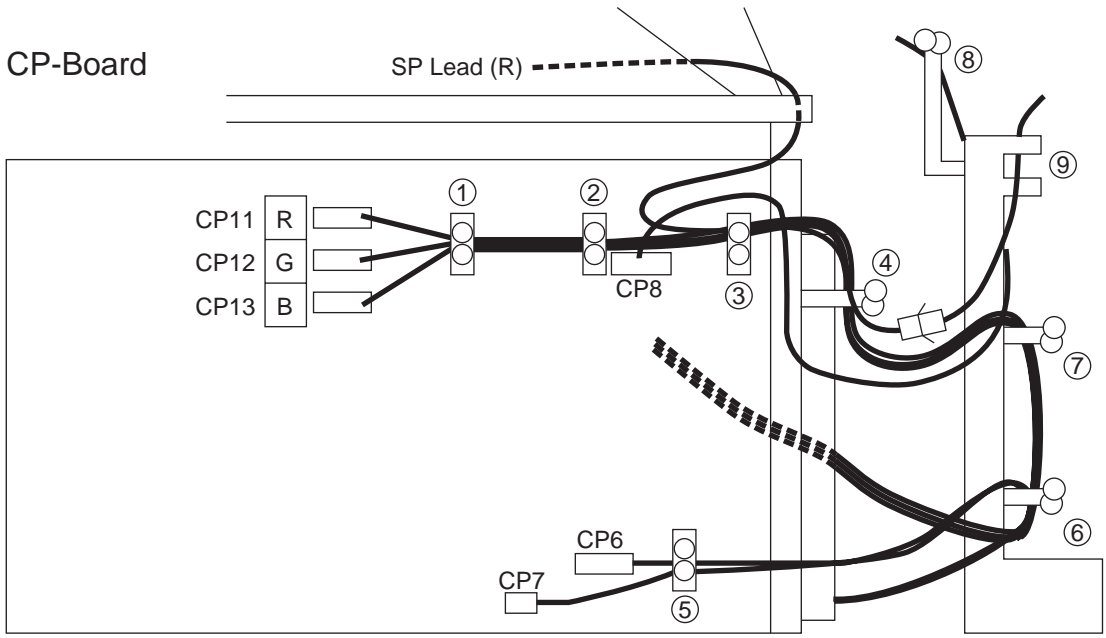

CLAMPER \ LEAD	①	②	③	④	⑤	⑥	⑦	⑧	⑨
CY-CP11, 12, 13	●	●	●	●		●	●		
P4-CP8								●	
F13-CP7					●	●			
SP~ REPLAY CONNECTOR			●	●					
H3~SP CONNECTION LEAD									●
A6, W4-CP6					●	●			

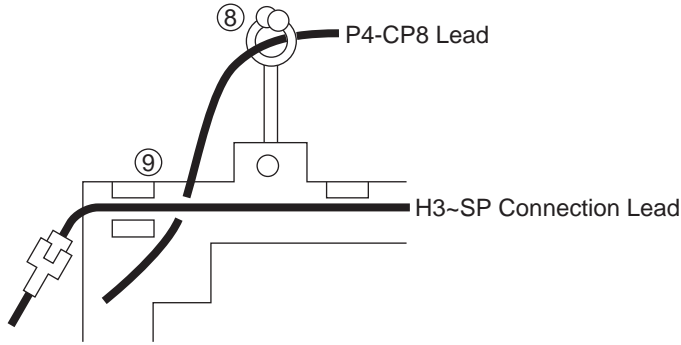

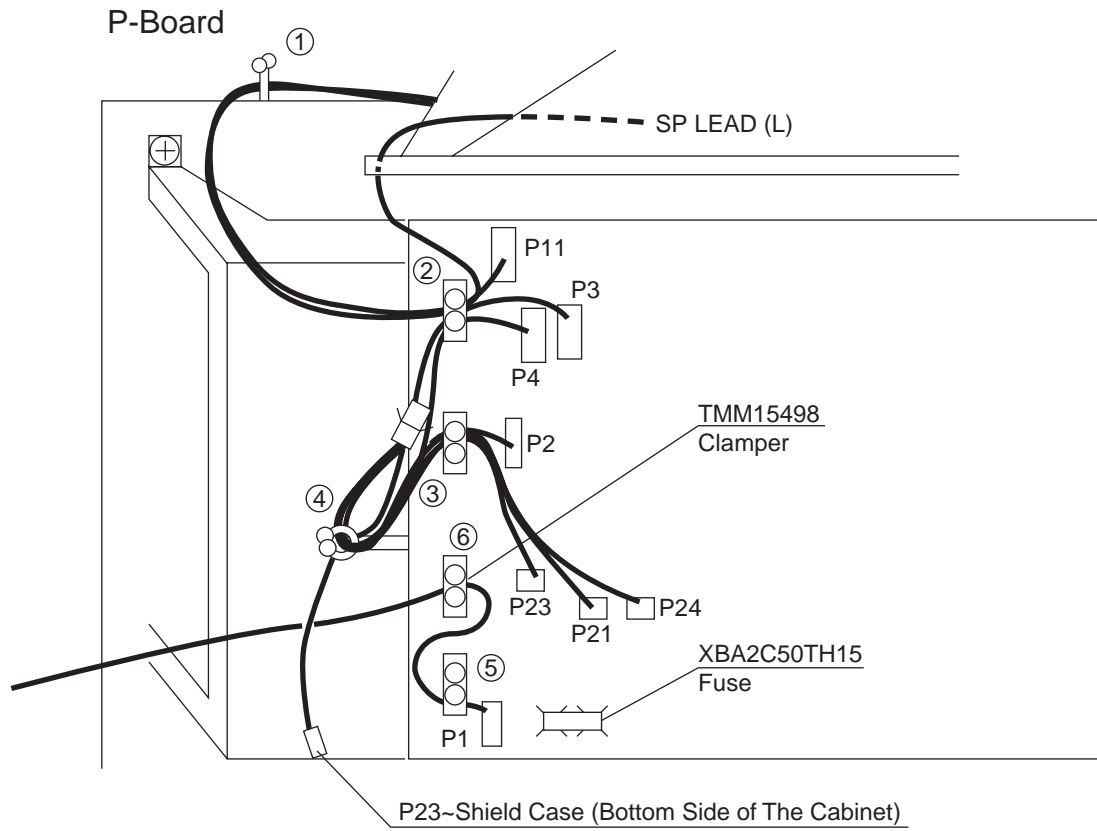

CLAMPER		CLAMPER					
		①	②	③	④	⑤	⑥
LEAD							
P4		●	●				
P3		●	●				
P2				●	●		
P23				●	●		
P24				●	●		
SP(L)~Replay Connector			●				
H3~SP Connector Lead				●			
P11			●	●			
P1 (AC Code)					●	●	
P21			●	●			

Conductor view

P-BOARD
TNPA1339

6
5
4
3
2
1

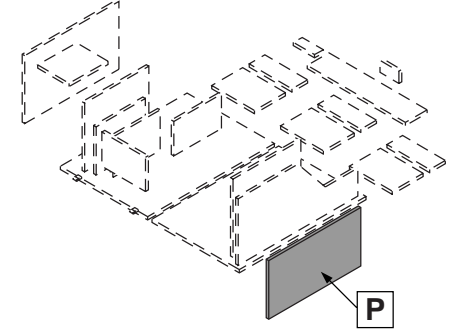
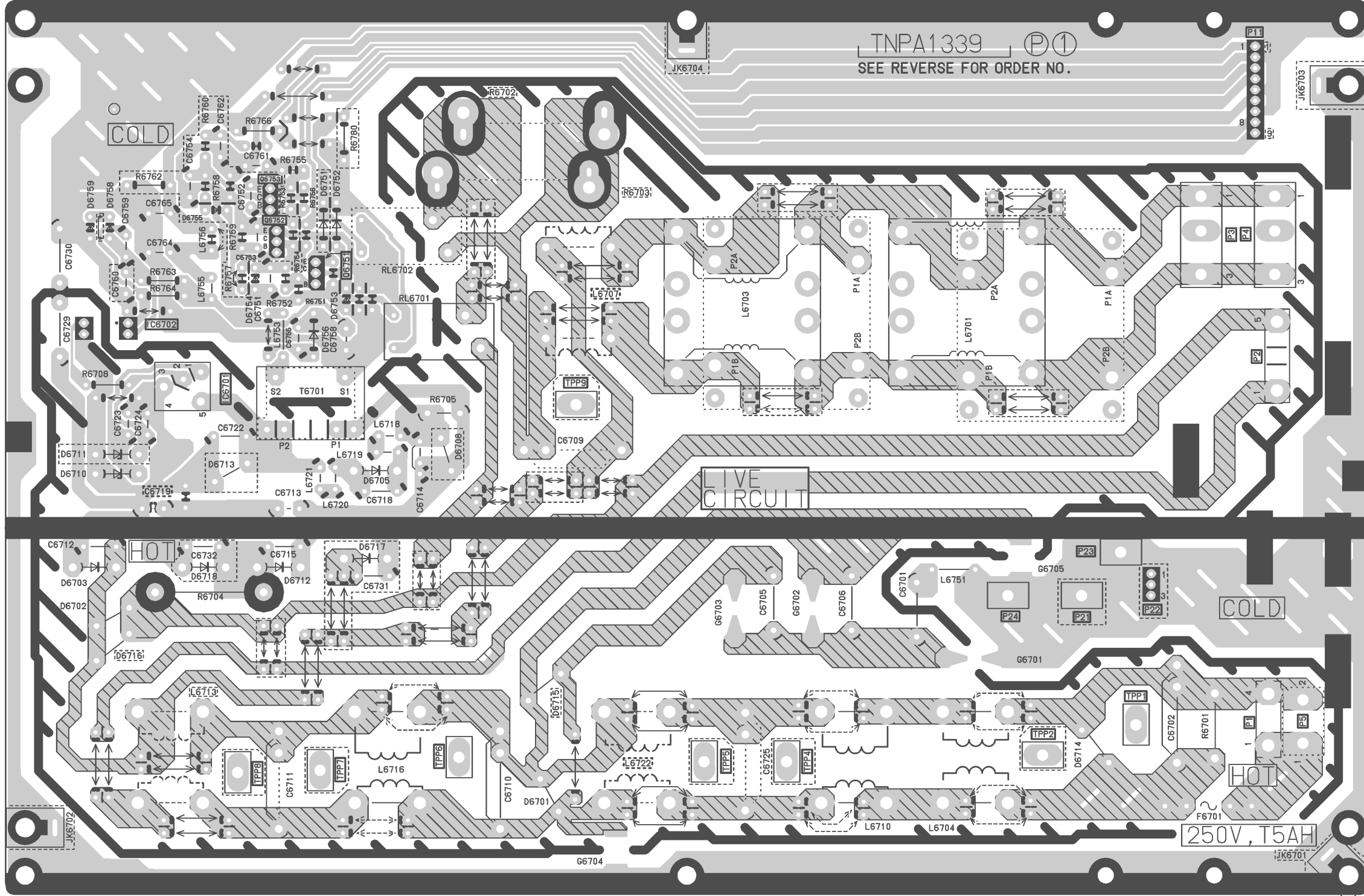

PARTS LOCATION

P-BOARD	
IC	
IC6701	B-4
IC6702	A-4
TRANSISTOR	
Q6751	B-4
Q6752	B-5
Q6753	B-5
TP	
TPP1	G-2
TPP2	G-2
TPP4	E-1
TPP5	E-1
TPP6	C-1
TPP7	C-1
TPP8	B-1
TPP9	D-4

ADDRESS INFORMATION

A B C D E F G H I

CP-BOARD
TNPA1227AB

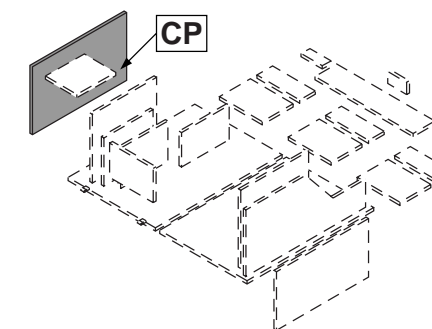

6
5
4
3
2
1

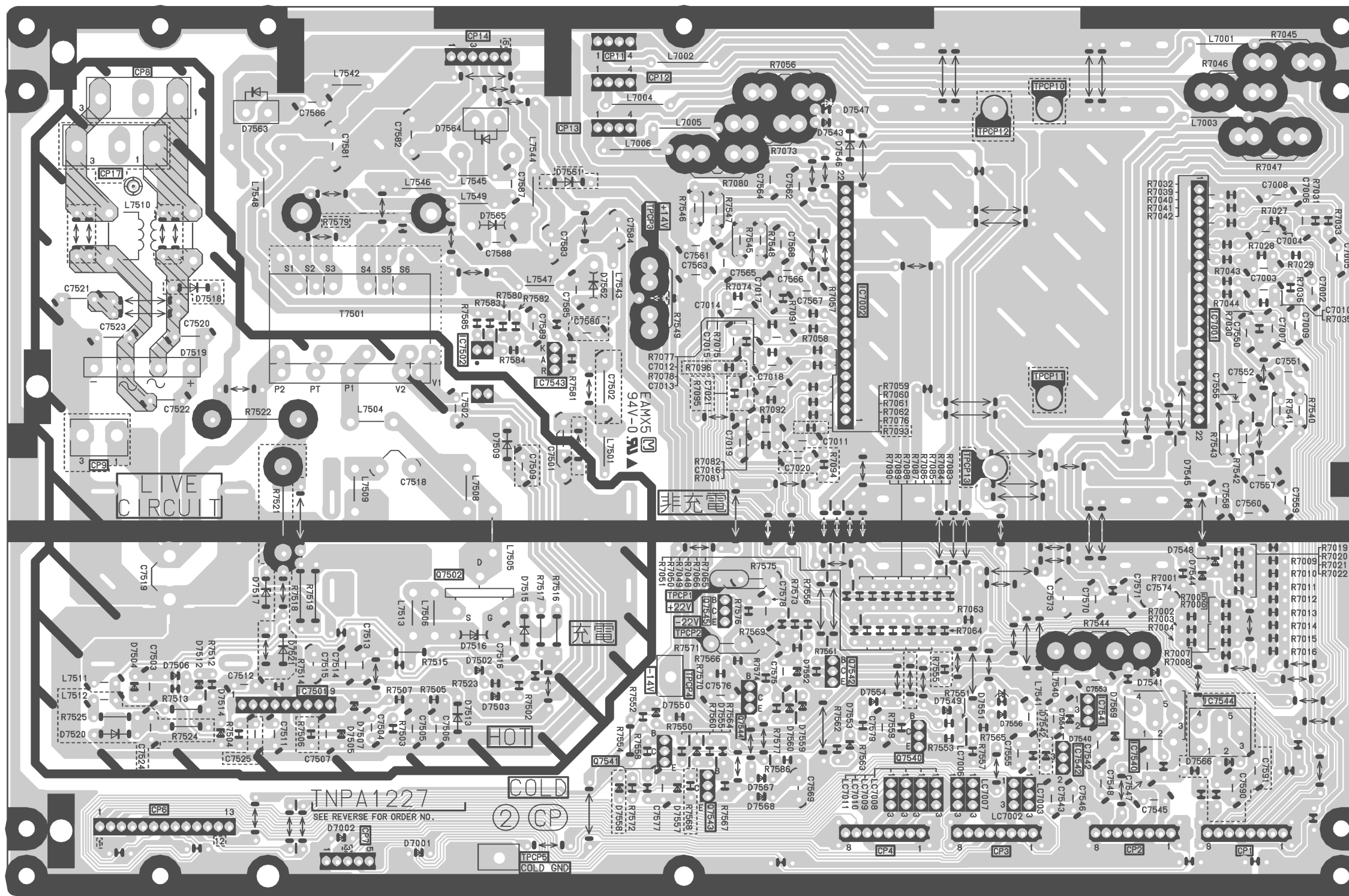

PARTS LOCATION

CP-BOARD	
IC	
IC7001	H-4
IC7002	F-4
IC7501	B-1
IC7502	C-4
IC7540	G-2
IC7541	G-2
IC7542	G-2
IC7543	D-4
IC7544	H-2
TRANSISTOR	
Q7502	C-2
Q7540	F-1
Q7541	D-1
Q7542	F-2
Q7543	E-1
Q7544	E-2
Q7545	E-2
TP	
TPCP4	E-2
TPCP5	D-1
TPCP10	G-5
TPCP11	G-4
TPCP12	F-5
TPCP13	F-3

ADDRESS INFORMATION

A

B

C

D

E

F

G

H

D-BOARD
TNPA1338

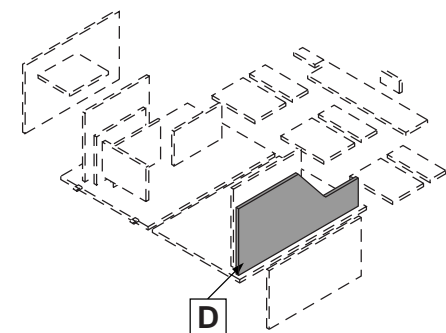
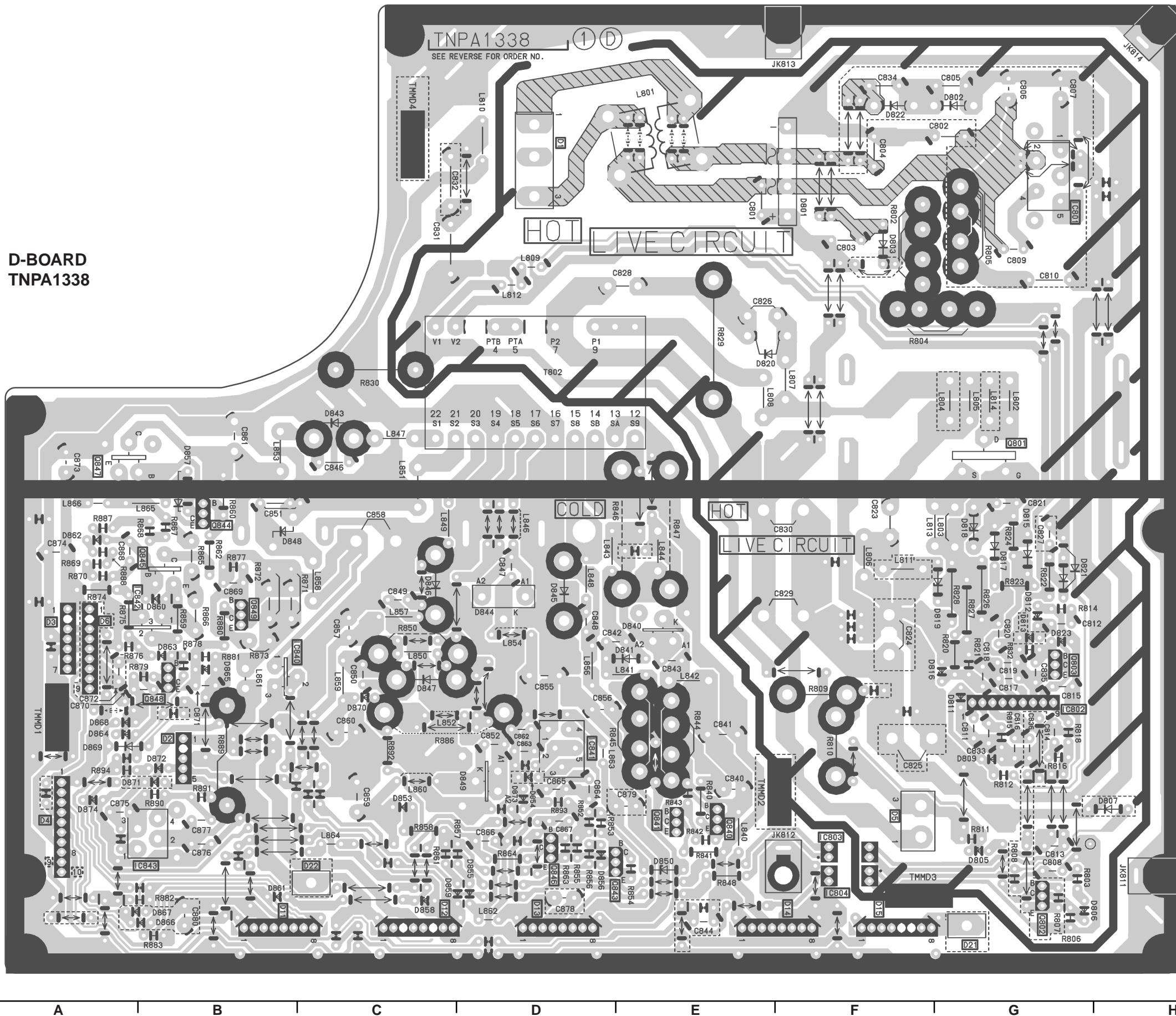

PARTS LOCATION

D-BOARD	
IC	
IC801	G-5
IC802	G-2
IC803	F-2
IC804	F-1
IC840	B-3
IC841	D-2
IC842	B-3
IC843	B-1
TRANSISTOR	
Q801	G-4
Q802	G-1
Q803	G-3
Q840	E-2
Q841	E-2
Q842	B-3
Q843	D-1
Q845	B-3
Q846	D-1
Q847	A-4
Q848	B-2
Q849	B-3

ADDRESS INFORMATION

A-BOARD
TNP0264AB

6

5

4

3

2

1

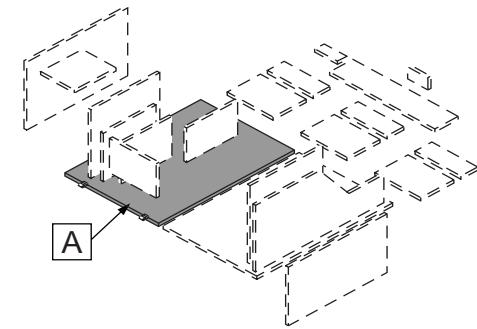
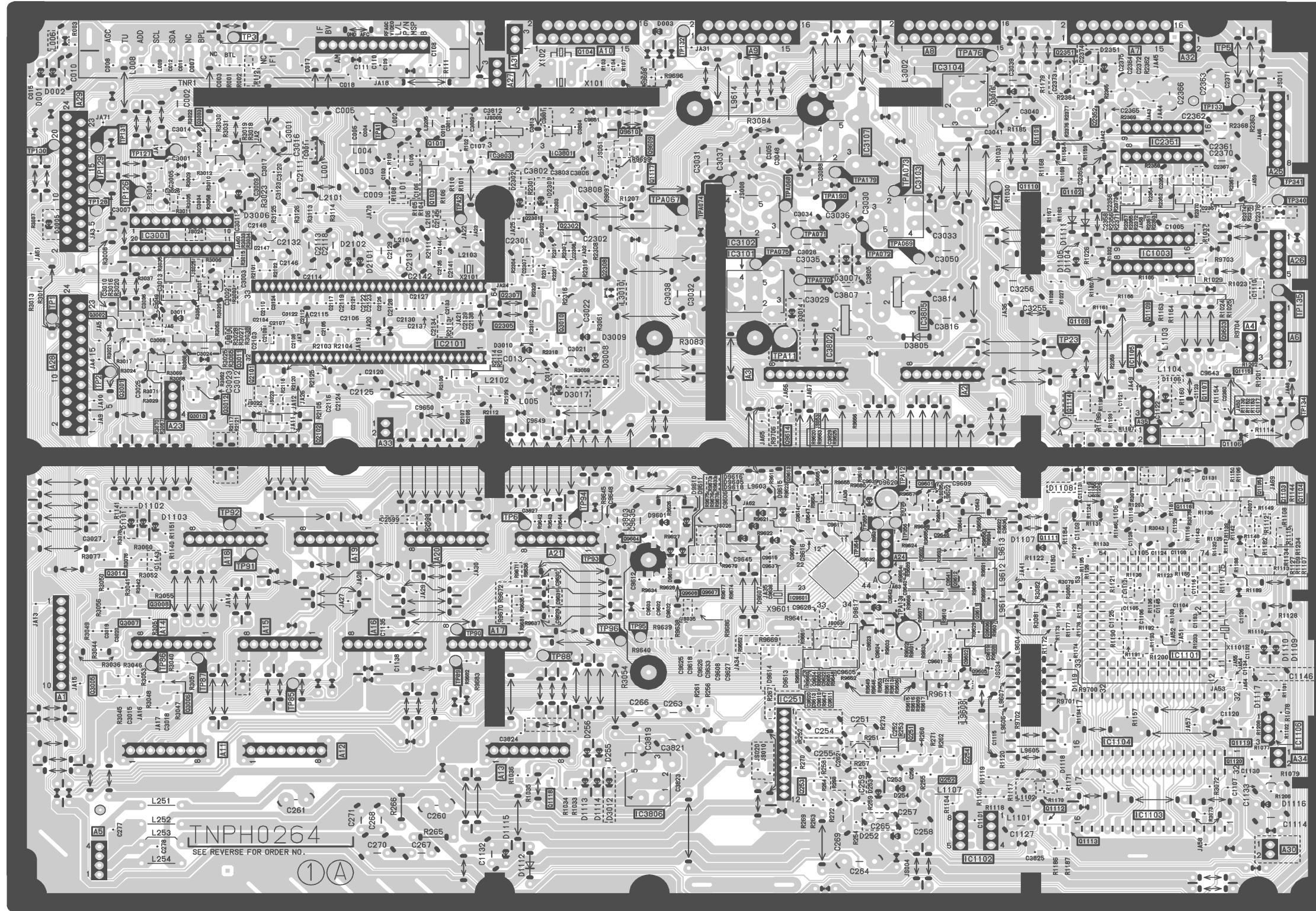

PARTS LOCATION

A-BOARD			
IC			
IC251	D-2	Q2301	C-4
IC1003	F-4	Q2302	C-4
IC1101	E-2	Q2305	C-4
IC1102	E-1	Q2307	C-4
IC1103	F-1	Q2308	C-4
IC1104	F-2	Q2351	F-5
IC1105	F-3	Q2352	F-5
IC1106	G-2	Q3001	A-4
IC2101	C-4	Q3002	A-4
IC2351	F-5	Q3003	B-5
IC3001	A-4	Q3005	A-2
IC3101	D-4	Q3006	A-2
IC3102	D-4	Q3007	A-2
IC3103	E-4	Q3008	A-2
IC3104	E-5	Q3010	C-4
IC3107	E-5	Q3012	B-3
IC3801	C-5	Q3013	B-3
IC3802	E-4	Q3014	A-2
IC3803	C-5	Q9601	E-3
IC3805	E-4	Q9602	E-2
IC3806	D-1	Q9603	G-4
IC9601	E-2	Q9604	D-3
		Q9605	E-2
		Q9606	E-2
		Q9607	D-2
		Q9608	D-2
		Q9609	D-5
		Q9610	D-5
		Q9611	E-2
		Q9612	E-2
		Q9613	E-3
		Q9614	E-3
TRANSISTOR			
Q101	C-5		
Q103	C-4		
Q104	C-5		
Q251	E-2		
Q252	E-1		
Q253	E-1		
Q254	E-1		
Q1101	F-5		
Q1102	F-4		
Q1103	G-3		
Q1104	G-3		
Q1105	G-3		
Q1106	G-3		
Q1107	G-3		
Q1108	F-4		
Q1109	F-4		
Q1110	F-4		
Q1111	F-3		
Q1112	F-1		
Q1113	F-1		
Q1114	F-3		
Q1115	G-4		
Q1116	F-3		
Q1117	D-5		
Q1118	C-1		
Q1119	G-2		
Q1120	G-1		
Q2101	B-3		
Q2102	B-3		
TP			
TPA1	C-5		
TPA2	C-4		
TPA11	E-4		
TPA12	E-3		
TPA13	E-2		
TPA67	D-4		
TPA68	E-4		
TPA69	E-4		
TPA70	E-4		
TPA71	E-4		
TPA72	E-4		
TPA73	E-5		
TPA74	D-4		
TPA75	D-4		
TPA76	E-5		
TPA179	E-5		
TPA190	E-4		

ADDRESS INFORMATION

A B C D E F G H I

D-BOARD/A-BOARD

E-BOARD
TNP0243AB

6

5

4

3

2

1

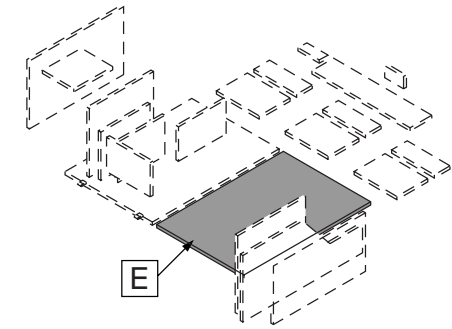
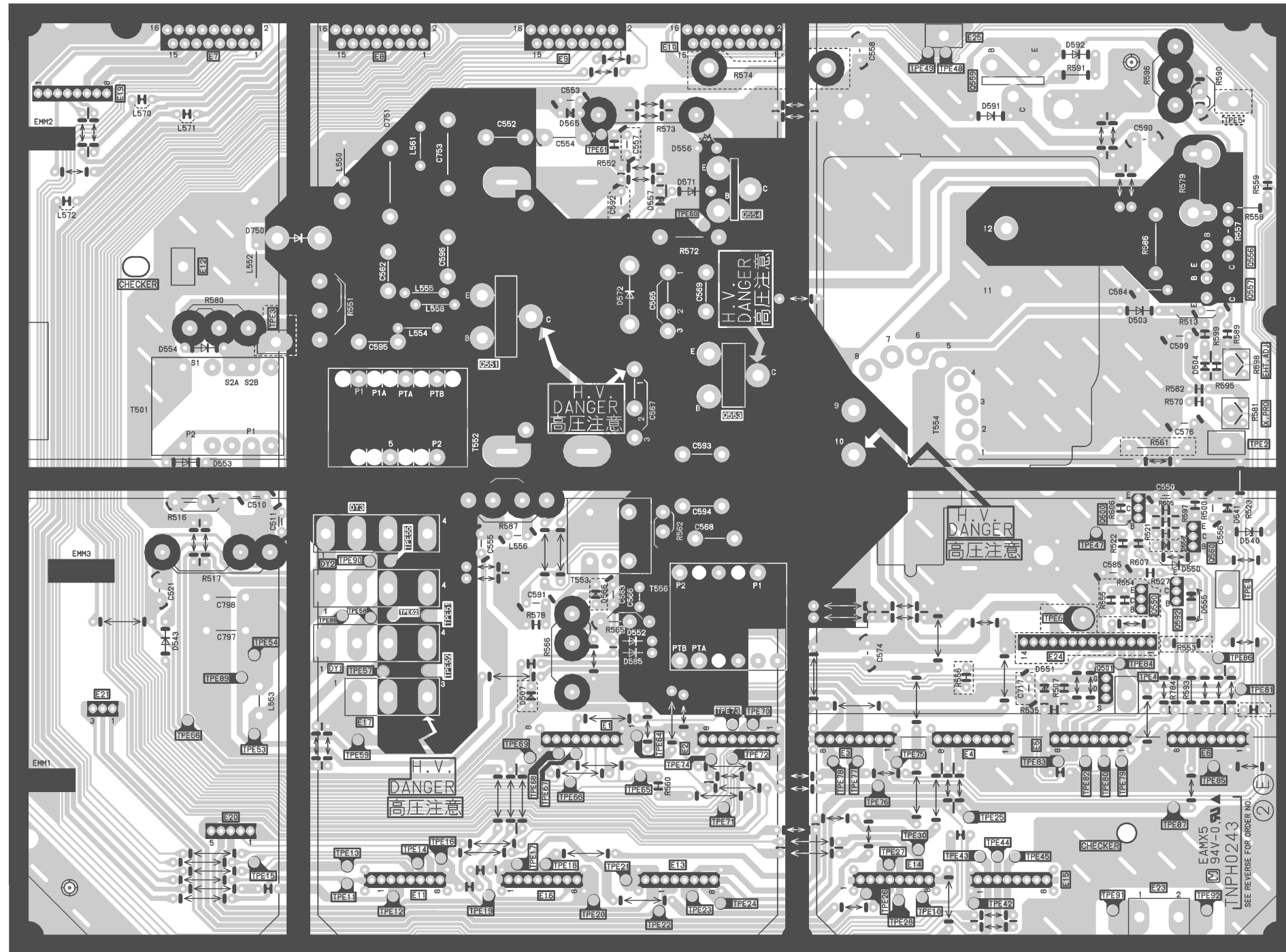

PARTS LOCATION

E-BOARD			
TRANSISTOR		TPE47	F-3
Q501	F-2	TPE48	E-5
Q550	F-2	TPE49	E-5
Q551	C-4	TPE51	C-2
Q553	D-3	TPE52	C-2
Q554	D-4	TPE53	B-2
Q556	G-4	TPE54	B-2
Q557	G-4	TPE55	C-2
Q559	F-5	TPE56	B-3
Q560	G-3	TPE57	B-2
Q592	G-2	TPE58	B-2
Q600	F-3	TPE59	B-2
		TPE60	D-4
TP		TPE61	D-5
TPE1	G-2	TPE62	C-2
TPE2	G-3	TPE64	D-2
TPE3	B-4	TPE65	D-2
TPE4	F-2	TPE66	C-1
TPE5	G-5	TPE67	C-1
TPE6	F-2	TPE68	C-1
TPE10	E-1	TPE69	C-2
TPE11	B-1	TPE70	D-2
TPE12	C-1	TPE71	D-1
TPE13	B-1	TPE72	D-2
TPE14	C-1	TPE73	D-2
TPE15	B-1	TPE74	D-2
TPE16	C-1	TPE75	E-2
TPE17	C-1	TPE76	E-1
TPE18	C-1	TPE77	E-2
TPE19	C-1	TPE78	E-2
TPE20	D-1	TPE79	F-2
TPE21	D-1	TPE80	F-2
TPE22	D-1	TPE81	G-2
TPE23	D-1	TPE82	F-2
TPE24	D-1	TPE83	F-2
TPE25	F-1	TPE84	F-2
TPE26	E-1	TPE85	G-1
TPE27	E-1	TPE86	G-2
TPE28	E-1	TPE87	G-1
TPE30	E-1	TPE88	B-2
TPE42	F-1	TPE89	B-2
TPE43	E-1	TPE90	B-3
TPE44	F-1	TPE91	F-1
TPE45	F-1	TPE92	G-1

ADDRESS INFORMATION

PARTS LOCATION

G-BOARD	
IC	
IC1801	C-2
IC1802	B-2
IC2501	C-3
TRANSISTOR	
Q1801	B-2
Q1802	C-2
Q1803	C-1
Q1804	C-3
Q1805	C-2
Q1806	C-2
Q2502	B-3
Q2505	B-4
Q2506	B-3
Q2507	B-4

ADDRESS INFORMATION

PARTS LOCATION

H-BOARD	
IC	
IC2401	H-2
IC2402	I-2
TP	
Q3405	F-1
Q3406	F-2
TRANSISTOR	
Q2401	H-3
Q2407	H-1
Q2408	H-1
Q2409	H-1
Q2410	H-1
Q2411	H-1
Q2412	H-1
Q3401	G-3
Q3402	F-4
Q3403	G-3
Q3404	F-4
TPH1	E-4
TPH2	H-2
TPH3	E-4

ADDRESS INFORMATION

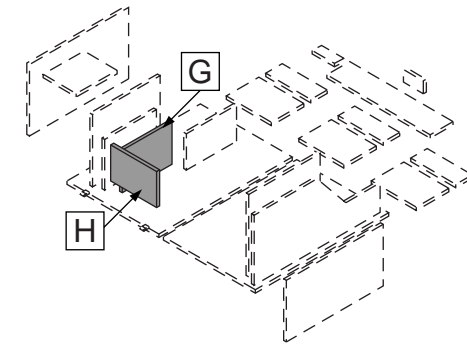

G-BOARD
TNPA1335

H-BOARD
TNPA1336

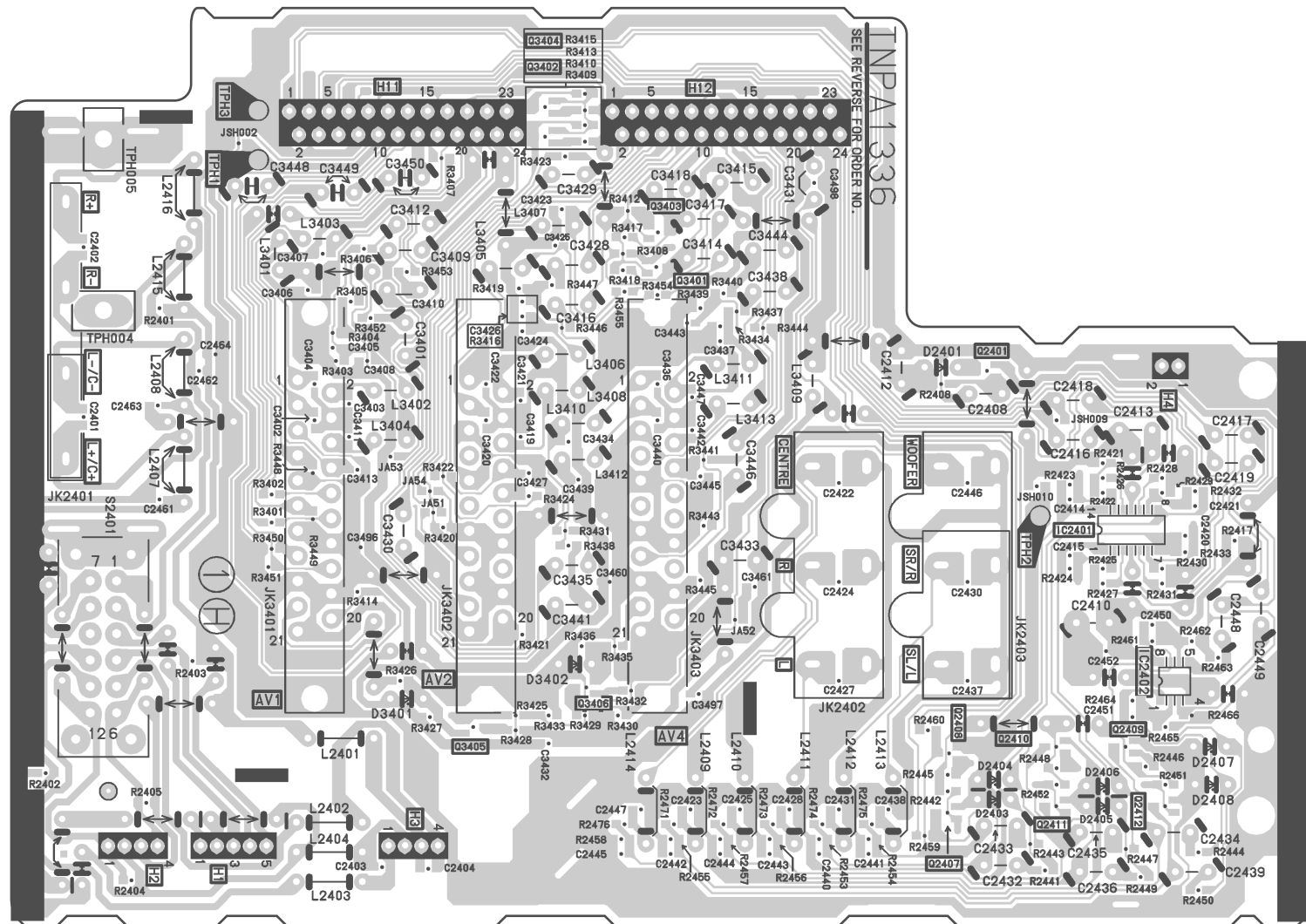
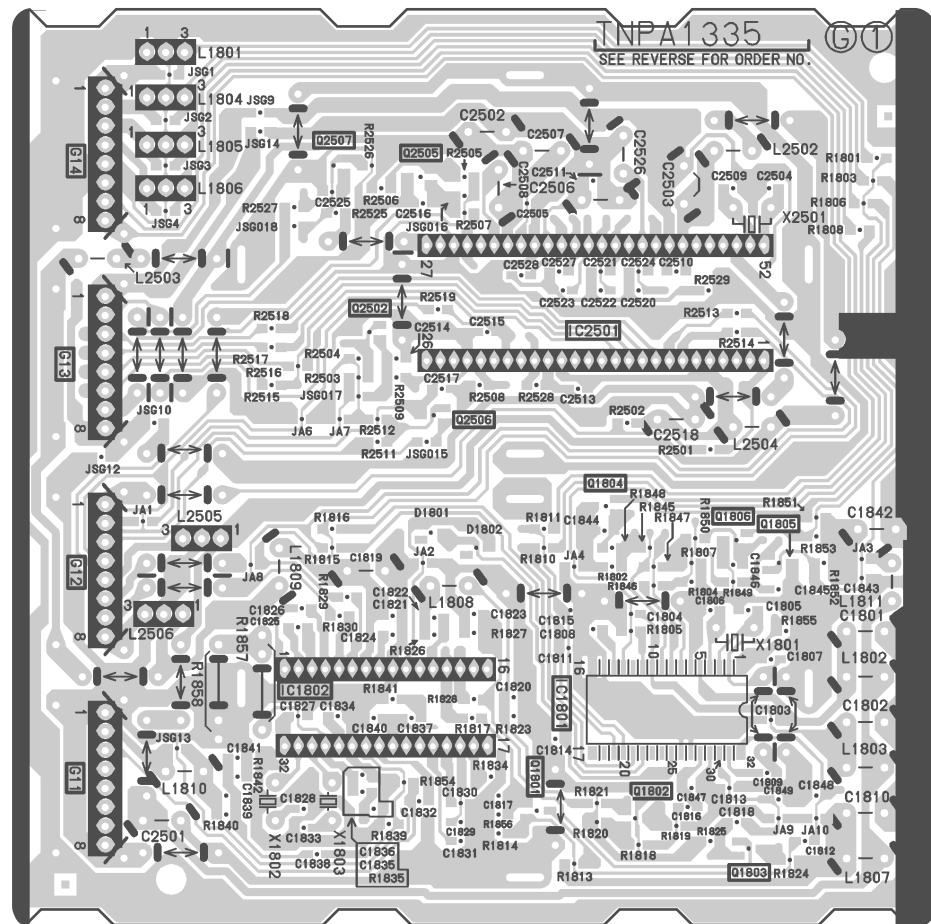

5
4
3
2
1

A B C D E F G H I

PARTS LOCATION

F-BOARD																	
IC		IC610	E-2	Q407	E-5	Q706	C-4	Q719	D-3	TPF5	E-5	TPE27	E-5	TPE39	E-4	TPE52	E-1
IC411	D-1	IC611	E-2	Q409	C-3	Q707	C-4	Q720	C-3	TPF6	C-5	TPE28	E-3	TPE41	E-3	TPE54	E-3
IC412	D-3	TRANSISTOR		Q410	D-4	Q708	C-1	Q721	D-4	TPF7	E-3	TPE29	E-1	TPE42	E-4	TPE56	D-3
IC451	A-3	Q400	B-4	Q411	D-5	Q709	C-2	Q722	D-4	TPF8	E-3	TPE30	E-4	TPE43	E-4	TPE57	E-2
IC452	B-3	Q401	D-5	Q503	E-1	Q710	A-3	Q723	D-4	TPF9	C-5	TPE31	E-2	TPE44	E-4	TPE58	C-5
IC453	D-3	Q402	D-5	Q504	C-3	Q711	B-2	Q724	C-2	TPF10	A-3	TPE32	E-1	TPE45	E-4	TPE59	
IC501	D-4	Q403	D-3	Q505	D-3	Q712	B-3			TPF11	A-3	TPE33	E-1	TPE46	E-3		
IC502	C-2	Q404	E-5	Q511	D-4	Q713	D-3			TPE20	E-3	TPE34	E-1	TPE47	E-3		
IC503	E-1	Q405	C-2	Q610	E-2	Q714	C-4			TPE21	E-3	TPE35	E-1	TPE48	E-3		
IC506	D-1	Q406	F-2	Q703	C-3	Q716	C-4			TPE23	E-3	TPE36	E-1	TPE49	E-5		
IC507	D-2	Q408	E-5	Q704	C-3	Q717	C-4			TPE24	E-3	TPE37	E-1	TPE50	E-3		
				Q705	C-4	Q718	D-4			TPE26	E-3	TPE38	D-4	TPE51	E-3		

ADDRESS INFORMATION

F-BOARD
TNPA1224AB

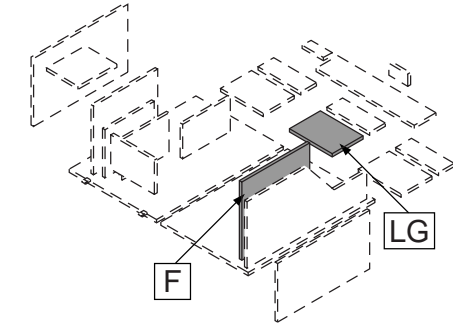
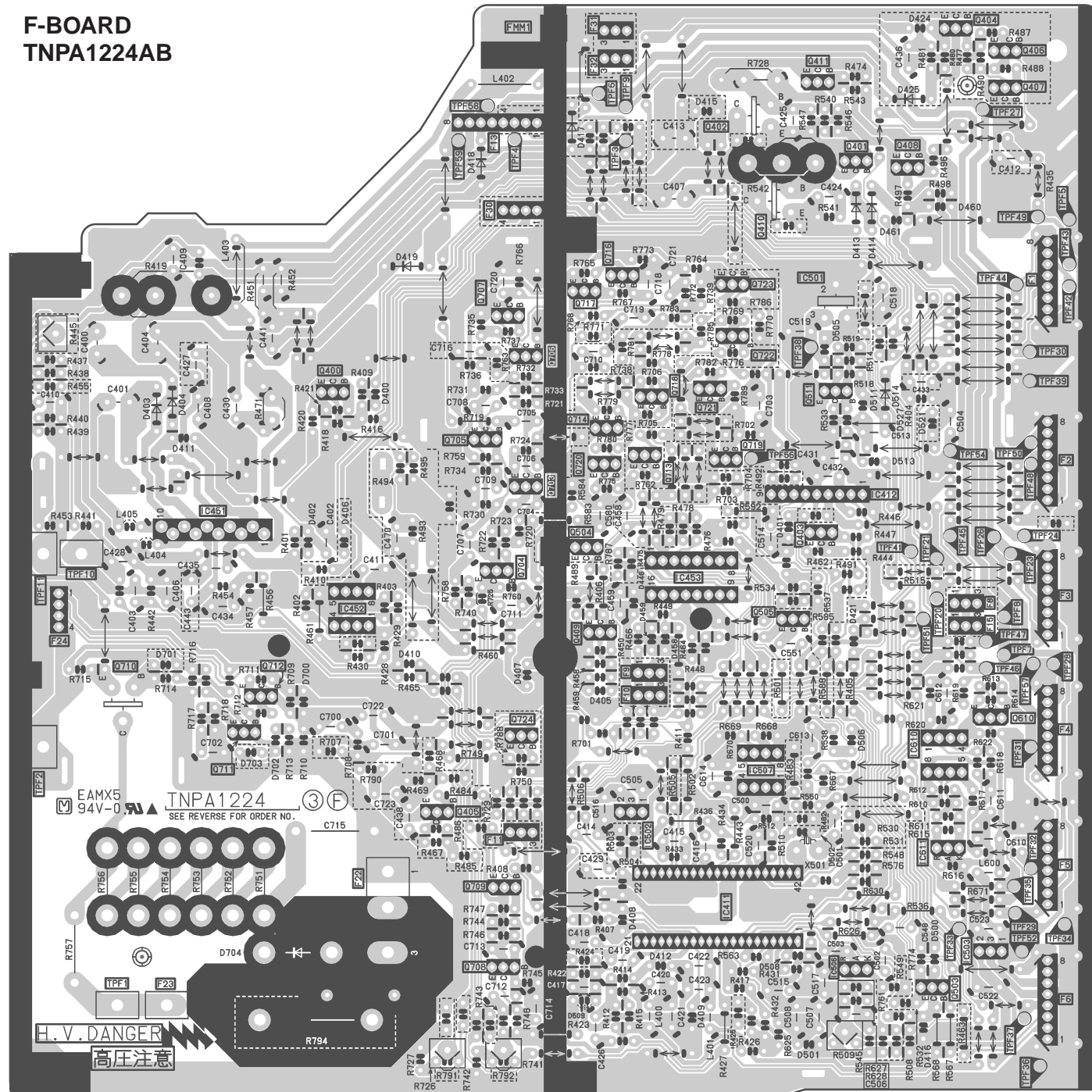

LG-BRD
TNPA0361AD

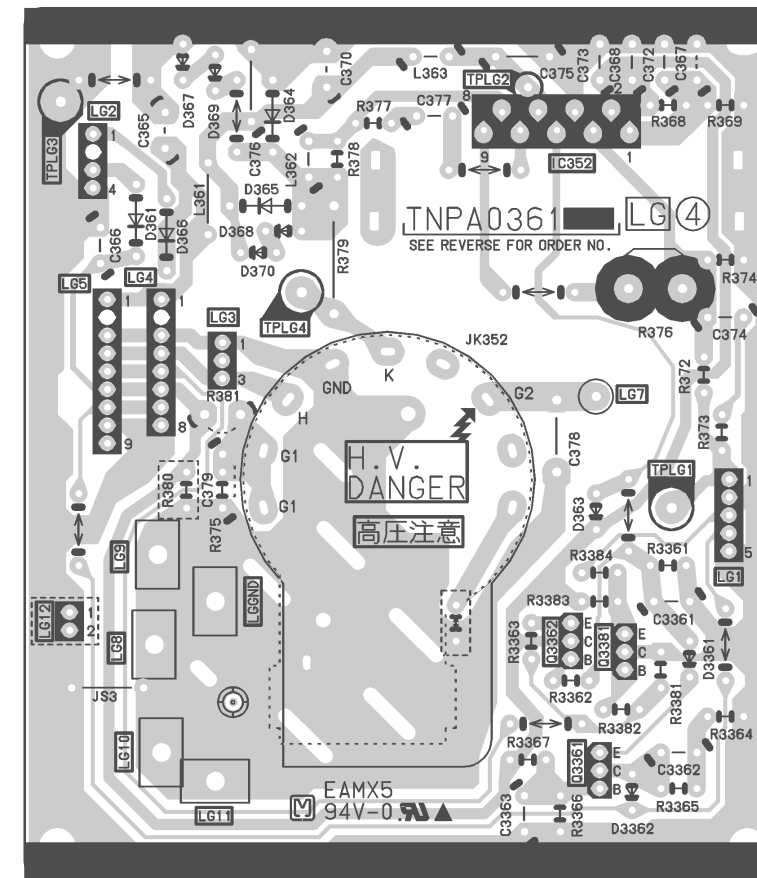

PARTS LOCATION

LG-BRD	
IC	
IC352	H-3
TRANSISTOR	
Q3361	H-1
Q3362	G-1
Q3381	H-1
TP	
TPLG1	H-2
TPLG2	G-3
TPLG3	F-3
TPLG4	G-3

ADDRESS INFORMATION

LB-BOARD
TNPA0362AD

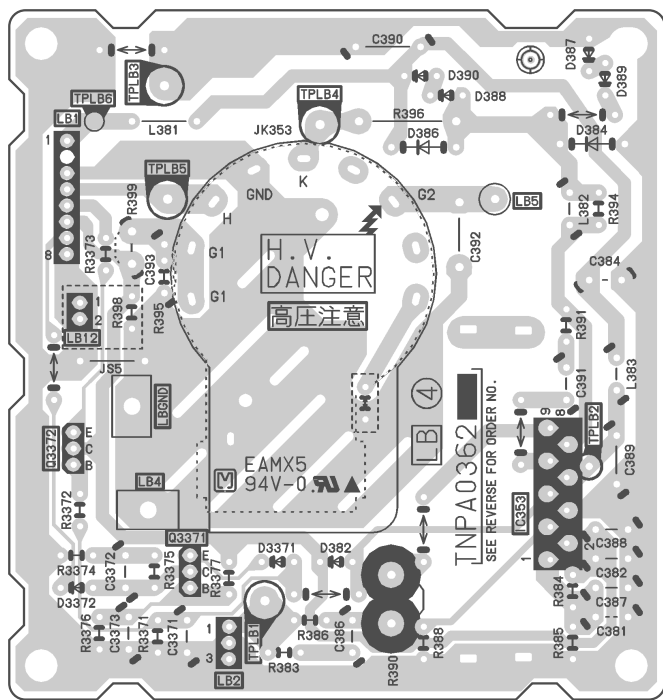

PARTS LOCATION

LB-BOARD	
IC	
IC353	B-4
TRANSISTOR	
Q3371	A-4
Q3372	A-5
TP	
TPLB1	A-4
TPLB2	C-5
TPLB3	A-6
TPLB4	B-6
TPLB5	A-6
TPLB6	A-6

ADDRESS INFORMATION

PARTS LOCATION

LR-BOARD	
IC	
IC351	B-3
TRANSISTOR	
Q3351	B-1
Q3352	B-1
TP	
TPLP1	C-1
TPLP2	B-3
TPLP3	A-3
TPLP4	A-2

ADDRESS INFORMATION

PARTS LOCATION

K-BOARD			
IC			
IC2551	D-4	Q2615	H-3
IC2630	G-2	Q2616	H-3
IC2640	G-1	Q2620	H-3
IC2650	E-2	Q2621	H-3
IC2660	E-1	Q2672	H-1
IC2670	G-4		
TRANSISTOR		TP	
Q2554	E-2	TPK1	F-1
Q2555	E-2	TPK2	G-1
Q2605	H-2	TPK3	G-2
Q2610	H-2	TPK4	F-1
Q2611	H-2	TPK5	E-2
		TPK6	E-1
		TPK7	H-4
		TPK8	H-2
		TPK9	F-3
		TPK12	H-1
		TPK13	H-2
		TPK14	H-1
		TPK15	H-2
		TPK16	H-2
		TPK17	D-1
		TPK18	E-1
		TPK19	F-1
		TPK20	F-1
		TPK21	G-1
		TPK22	G-1

ADDRESS INFORMATION

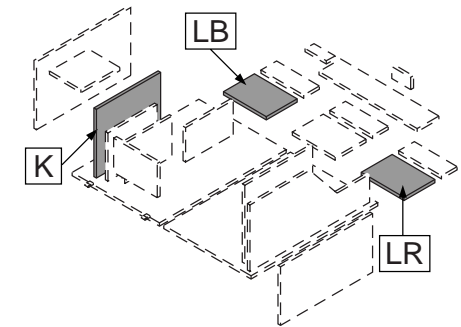

K-BOARD
TNPA1337

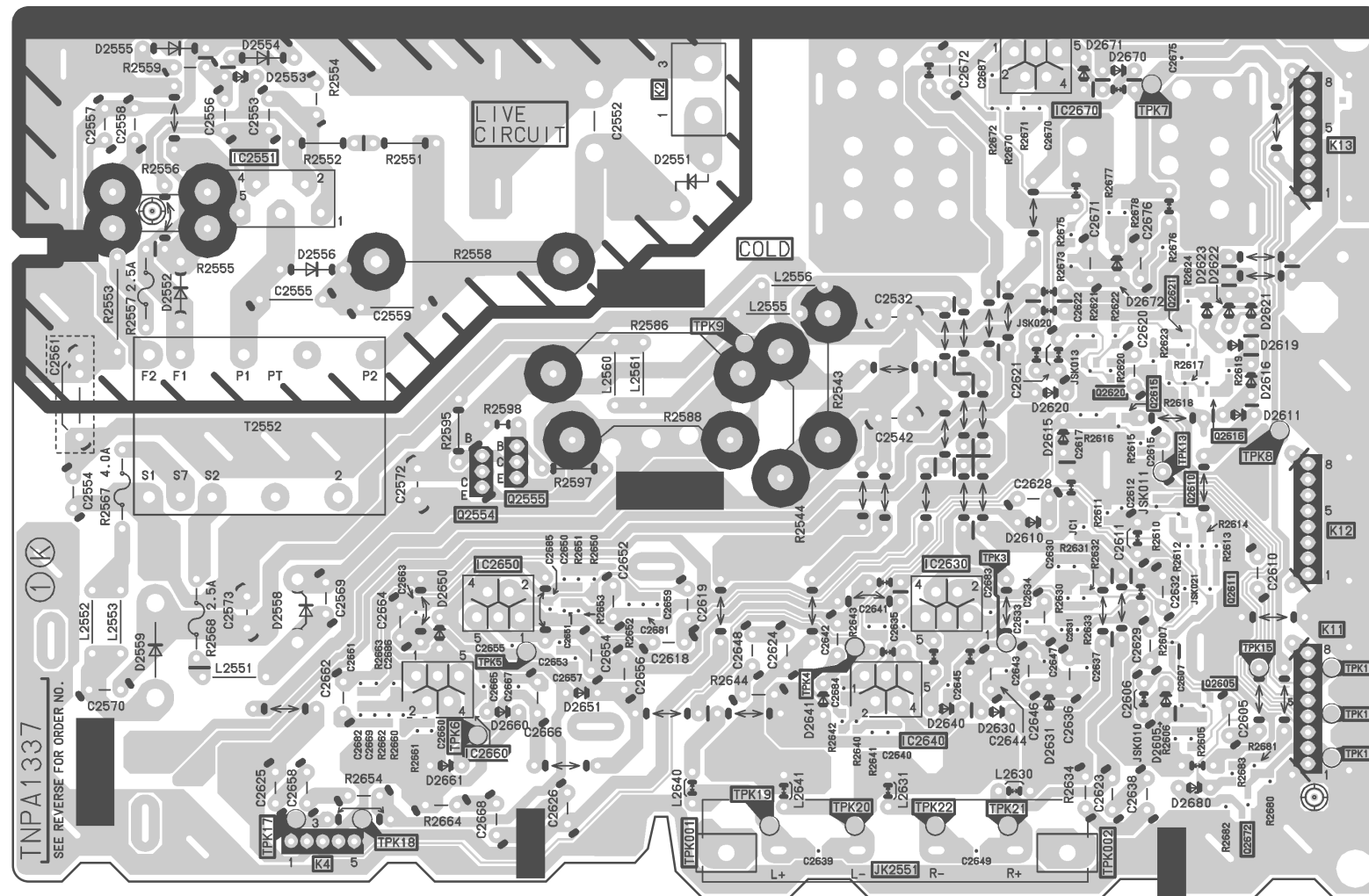

LR-BOARD
TNPA0360AD

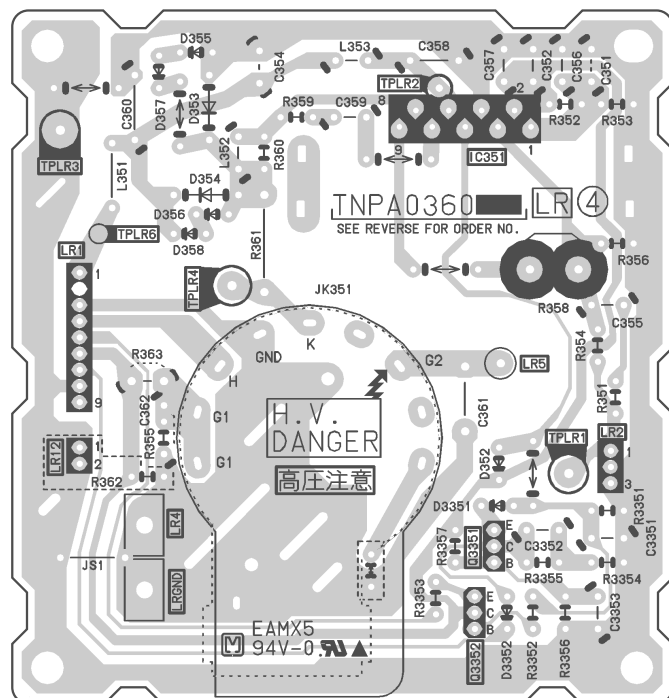

6

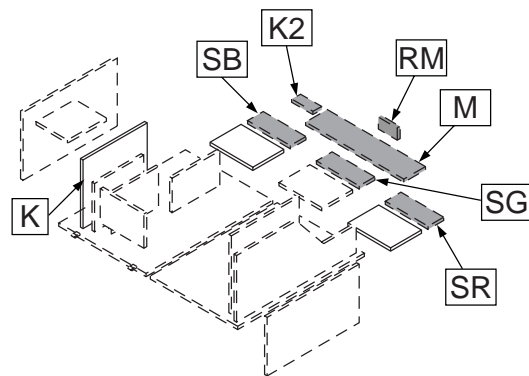

**K2-BOARD
TNPA1341**

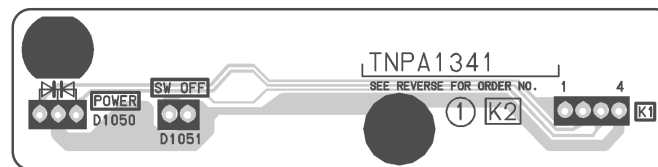

**RM-BOARD
TNPA1342**

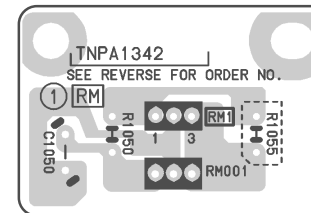

5

**SG-BOARD
TNPA1405**

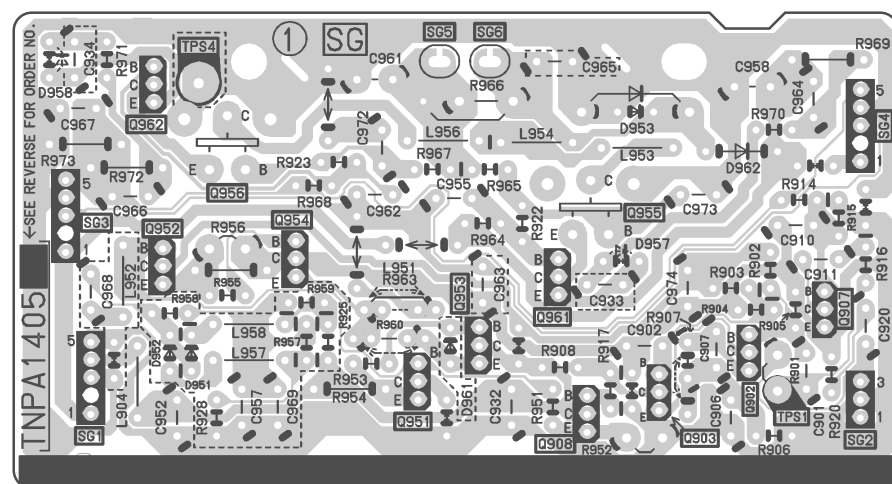

**SB-BOARD
TNPA1408**

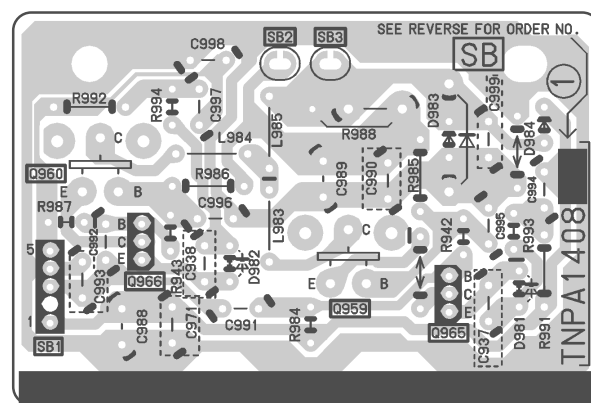

**SR-BOARD
TNPA1406**

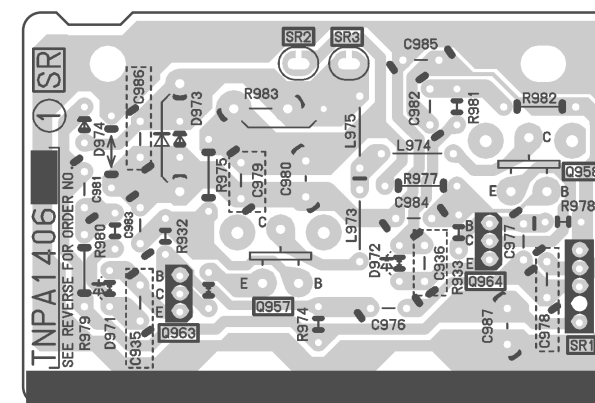

3

**M-BOARD
TNPA1340**

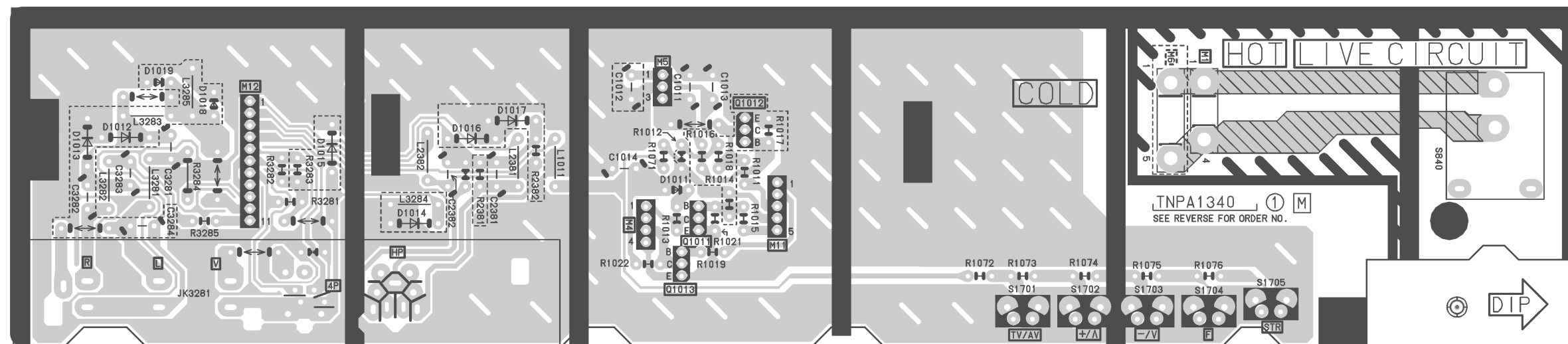

1

2

A

B

C

D

E

F

G

H

6 DC-BOARD (FOIL SIDE)
TNPA1226AB

DC-BOARD (COMPONENT SIDE)
TNPA1226AB

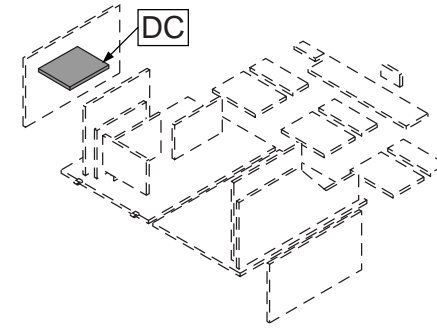
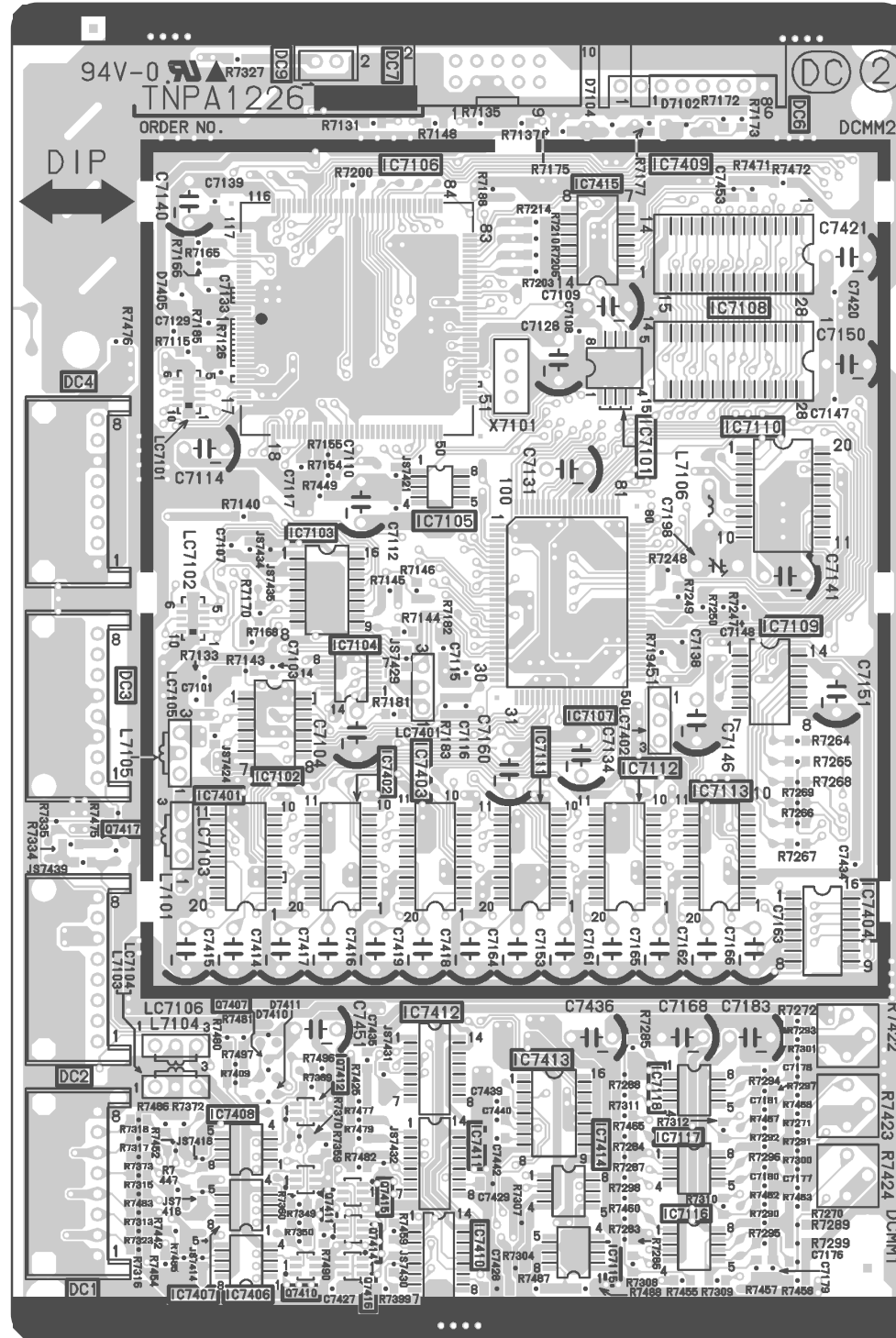
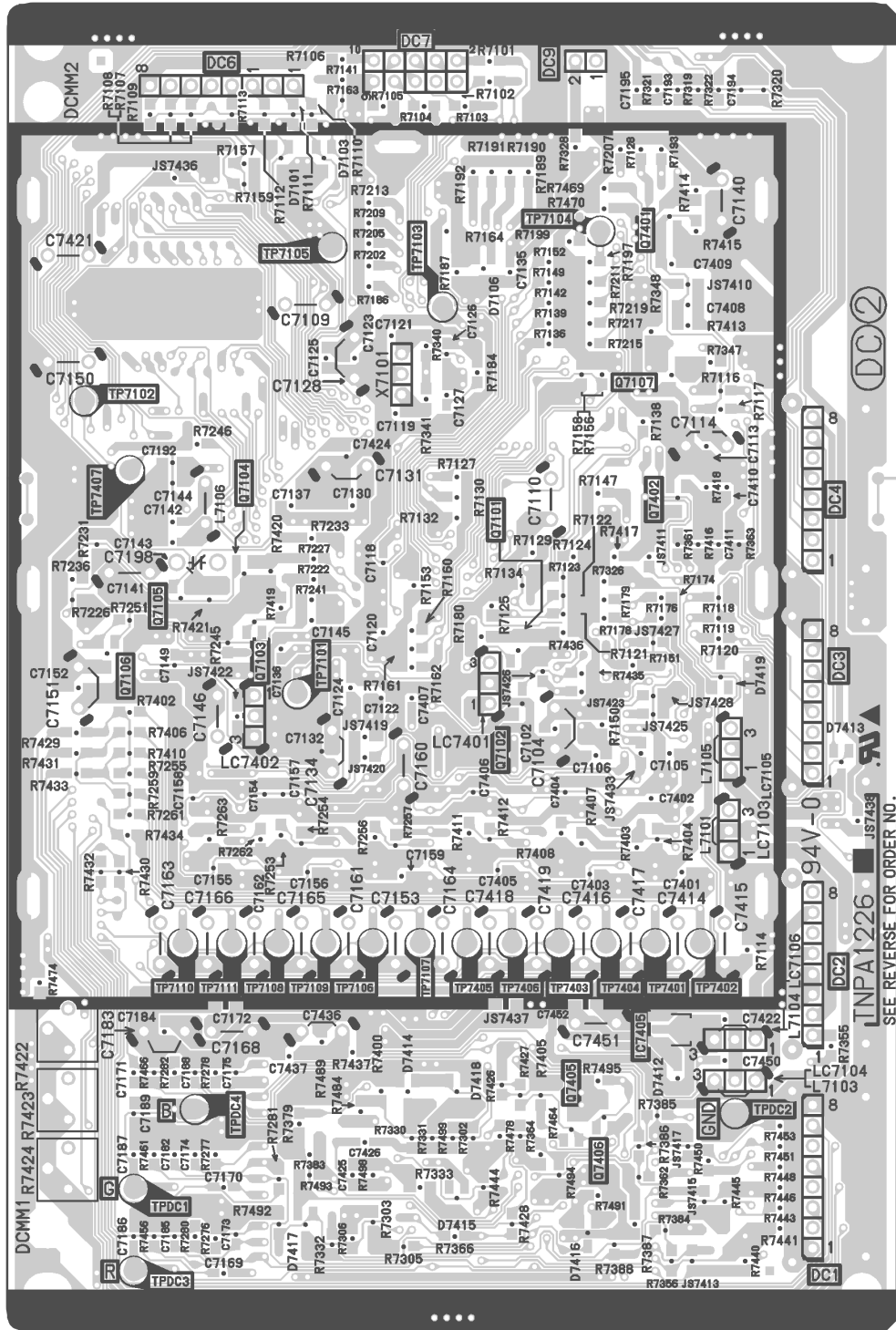

PARTS LOCATION

P-BOARD			
IC		TRANSISTOR	
IC7101	G-4	Q7101	C-4
IC7102	E-3	Q7102	C-3
IC7103	E-4	Q7103	B-32
IC7104	F-3	Q7104	B-4
IC7105	F-4	Q7105	A-3
IC7106	F-5	Q7106	A-3
IC7107	F-3	Q7107	C-4
IC7108	G-5	Q7401	C-5
IC7109	G-3	Q7402	C-4
IC7110	G-4	Q7405	C-2
IC7111	F-3	Q7406	C-1
IC7112	G-3	Q7407	E-2
IC7113	G-3	Q7410	E-1
IC7115	G-1	Q7411	E-1
IC7116	G-1	Q7412	F-2
IC7117	G-1	Q7414	F-1
IC7118	G-2	Q7415	F-1
IC7401	E-3	Q7416	F-1
IC7402	F-3	Q7417	E-3
IC7403	F-3		
IC7404	G-2		
IC7405	C-2		
IC7406	E-1		
IC7407	E-1		
IC7408	E-1		
IC7409	G-5		
IC7410	F-1		
IC7411	F-1		
IC7412	F-2		
IC7413	F-2		
IC7414	F-1		
IC7415	G-5		

ADDRESS INFORMATION

PARTS LOCATION

P-BOARD		IC		TRANSISTOR		TP	
IC7701	H-1	Q7710	D-1	Q7734	B-3	TPW12	A-2
IC7702	F-4	Q7711	D-1	Q7735	D-4	TPW13	A-2
IC7703	F-2	Q7712	D-1	Q7736	B-3	TPW14	A-2
IC7704	G-4	Q7714	D-2	Q7737	B-3	TPW15	A-2
IC7705	E-4	Q7715	F-2	Q7738	B-3	TPW16	A-2
IC7706	F-4	Q7716	D-2	Q7741	A-3	TPW17	A-2
		Q7717	F-3	Q7742	A-4	TPW18	A-2
		Q7718	F-2	Q7743	B-32	TPW19	A-2
		Q7721	B-1	Q7744	B-4	TPW20	B-1
Q7701	A-1	Q7722	B-1	Q7745	A-4	TPW21	B-1
Q7702	A-1	Q7723	B-1	Q7746	B-4	TPW22	C-1
Q7703	A-1	Q7724	B-2	Q7747	B-4	TPW23	C-1
Q7704	A-1	Q7725	B-2	Q7748	C-3	TPW24	C-1
Q7705	A-2	Q7726	B-2	Q7749	B-3	TPW25	C-1
Q7706	B-1	Q7727	D-1			TPW26	A-4
Q7707	B-2	Q7731	B-2			TPW27	A-4
Q7708	B-2	Q7732	A-2			TPW28	A-3
Q7709	B-2	Q7733	C-3			TPW29	A-3

ADDRESS INFORMATION

W-BOARD (FOIL SIDE)
TNPA0359

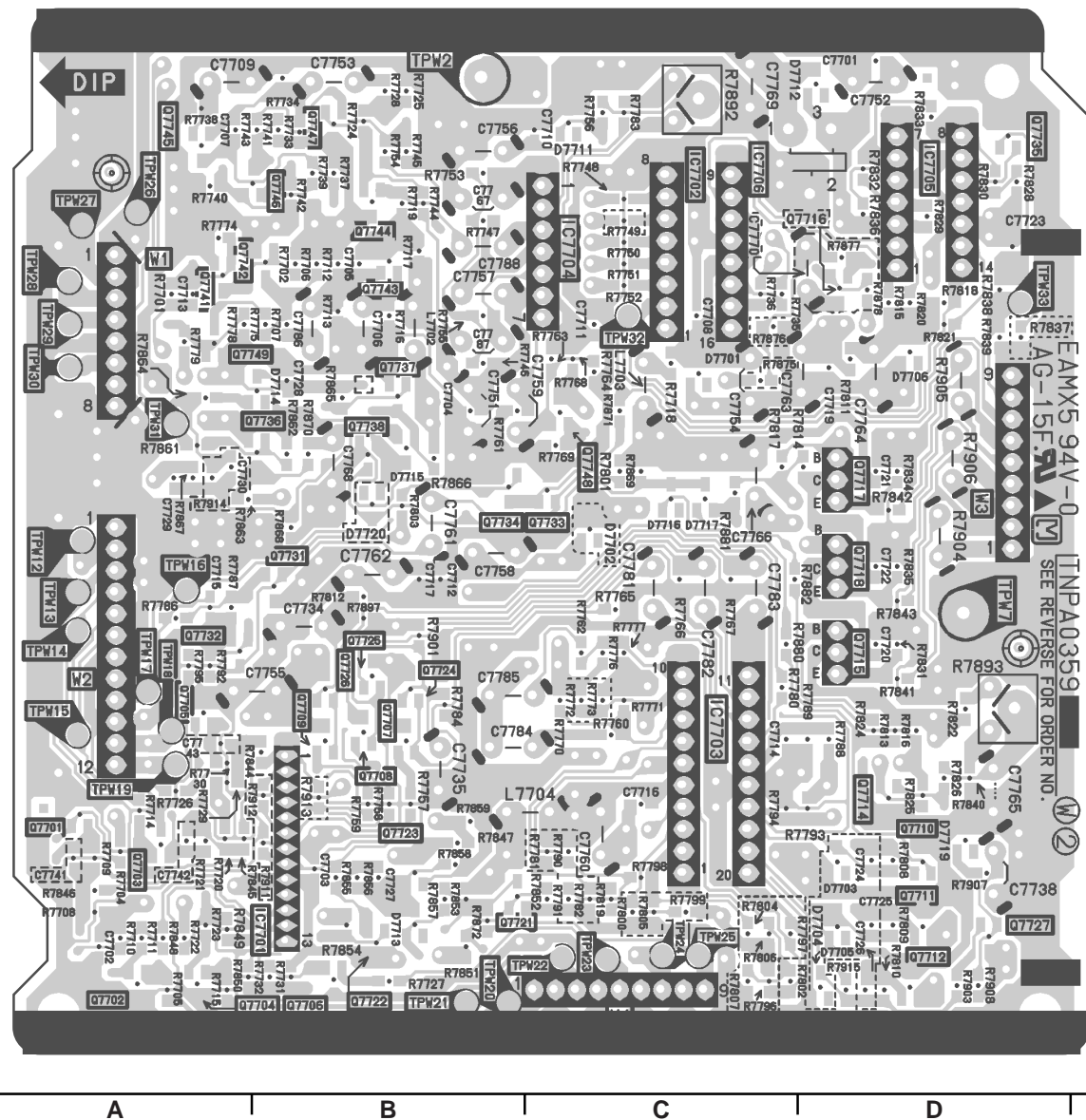

W-BOARD (COMPONENT SIDE)
TNPA0359

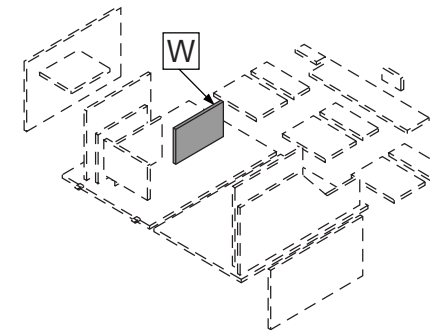
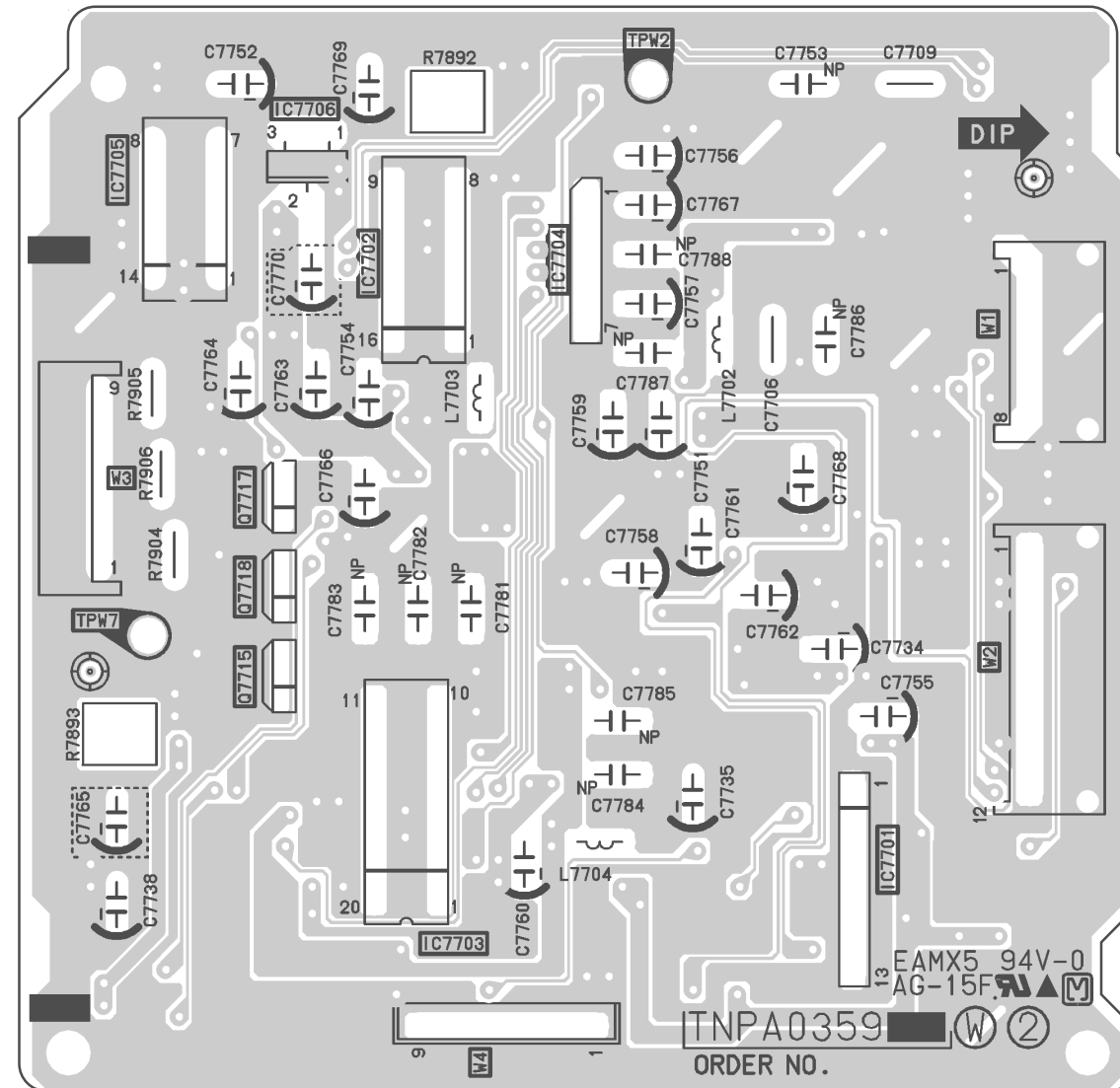

CONTROL BLOCK DIAGRAM

TX-47PT1F

TX-47PT1F

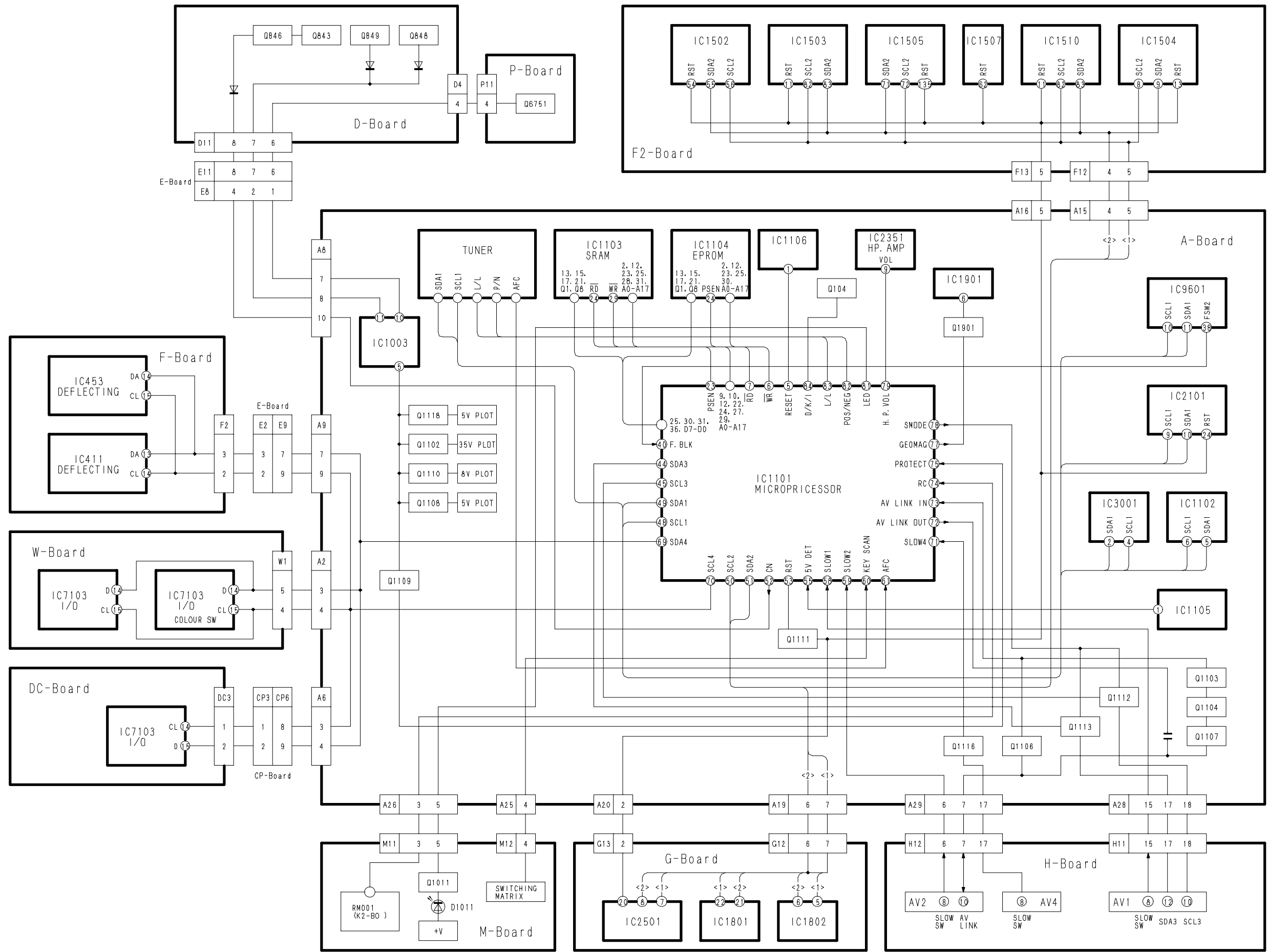

W-BOARD/CONTROL BLOCK DIAGRAM

VIDEO BLOCK DIAGRAM

TX-47PT1F

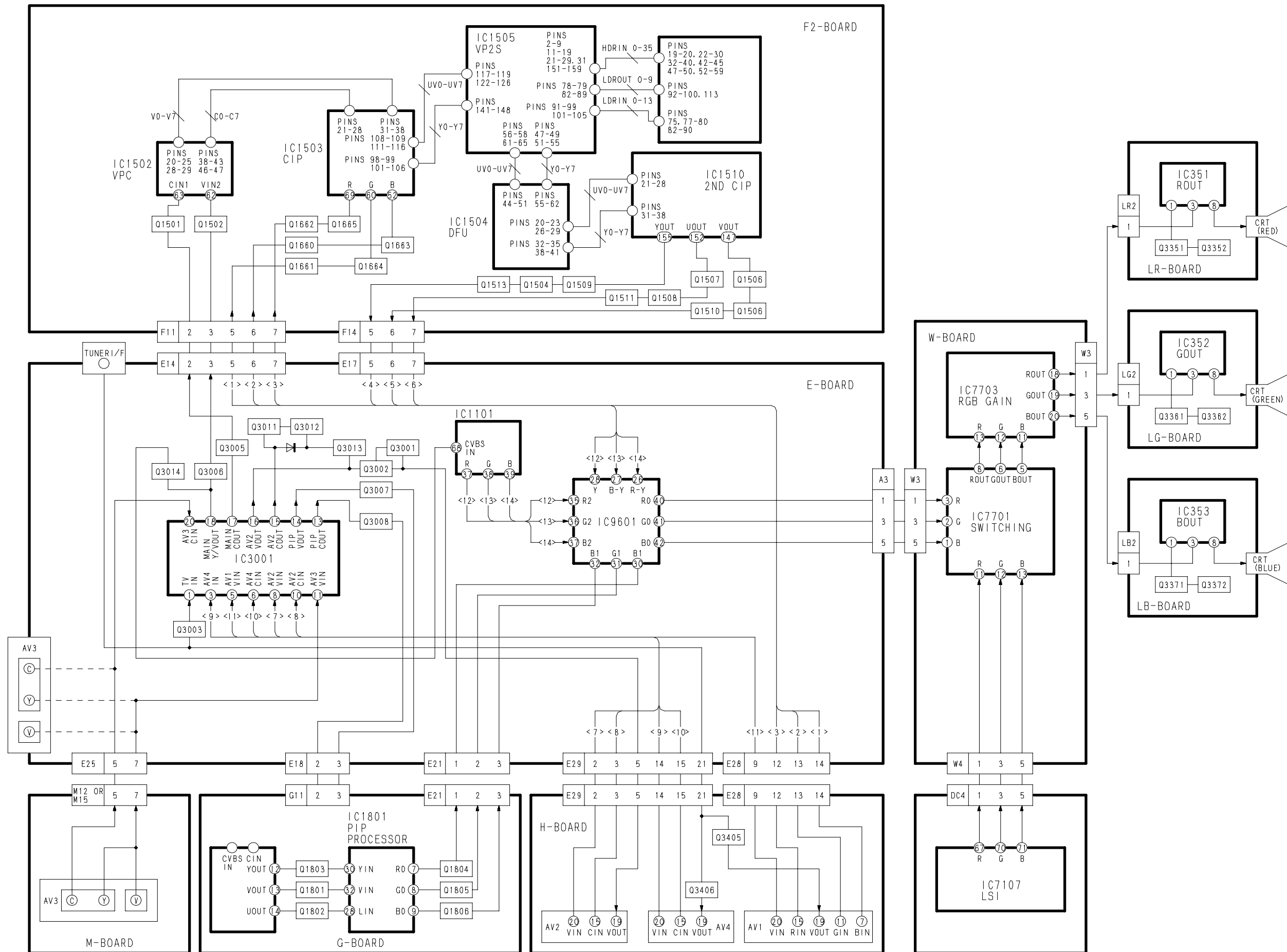

AUDIO BLOCK DIAGRAM

TX-47PT1F

TX-47PT1F

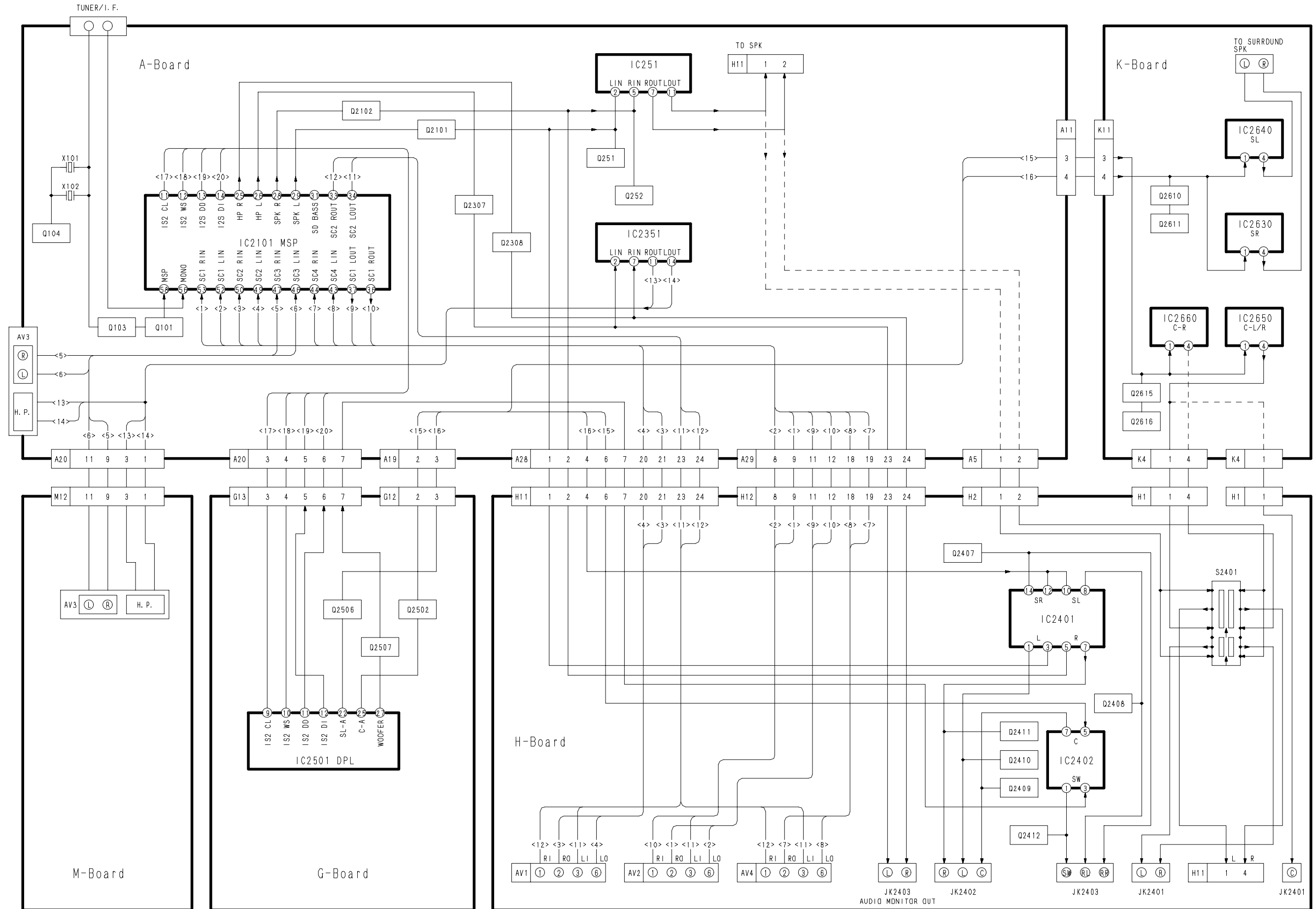

Remote Control Transmitter/ EUR511020

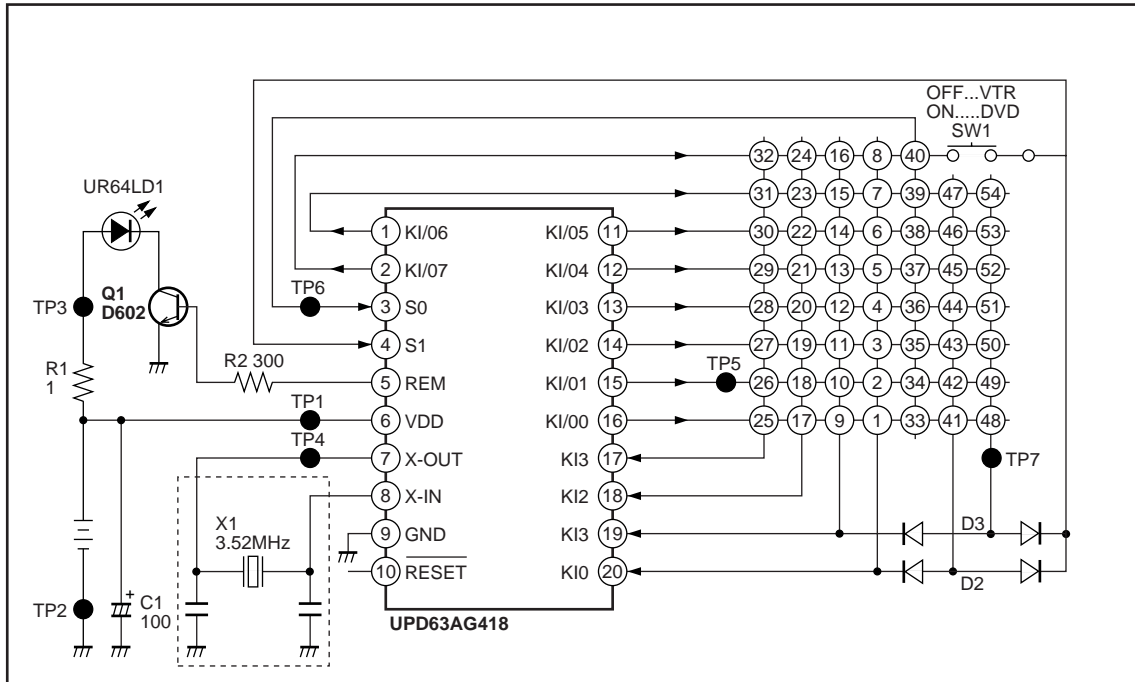

Key Function table

KEY NO.	FUNCTION NAME	KEY NO.	FUNCTION NAME	KEY NO.	FUNCTION NAME
2	STORE	18	NEXT VIEW	32	4
3	2 DIGIT	19	0	36	CH POS DOWN
4	TV/TEXT	20	VOL DOWN	37	YELLOW
5	2	21	RECALL ON/OFF	38	CH POS UP
6	INDEX PAGE	22	POWER ON/OFF	42	TEST MODE
7	5	23	GREEN	43	NORMAL
8	8	24	F.P. (QUICK TEXT)	44	SURROUND
10	HELP	25	C	45	VOL UP
11	9	26	SET UP (MENU)	46	MUTE
12	CYAN	27	7	47	DIRECT TV REC
13	HOLD	28	SOUND (F. AUDIO)	48	PIP ON/OFF
14	TV/AV	29	RED	49	ASPECT
15	3	30	PICTURE (F. VIDEO)	2+21	CHILD LOCK
16	6	31	1		

	SW1 VTR	SW2 DVD
KEY NO.	FUNCTION NAME	FUNCTION NAME
1	CH DOWN	_____
9	CH UP	_____
17	PAUSE	_____
33	POWER	POWER
34	F.F.	SKIP (FWD)
35	REW	SKIP (BACK)
39	PLAY	PLAY
40	STOP	STOP
41	REC	_____
50	_____	SLOW/ SEARCH (REV)
51	_____	SLOW/ SEARCH (FWD)
52	ADVANCE	PAUSE/ STILL
53	MULTI	_____
54	_____	OPEN/ CLOSE

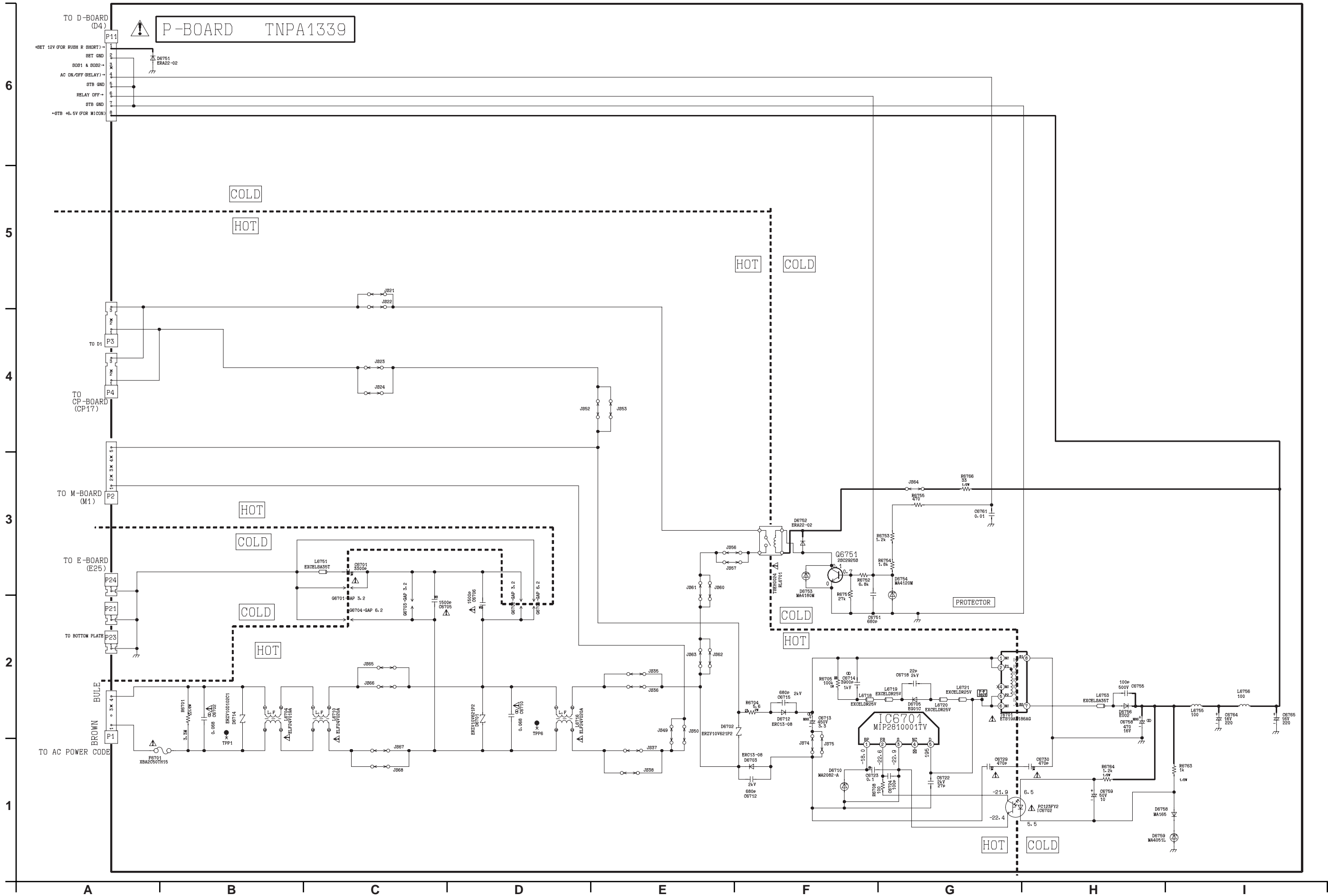

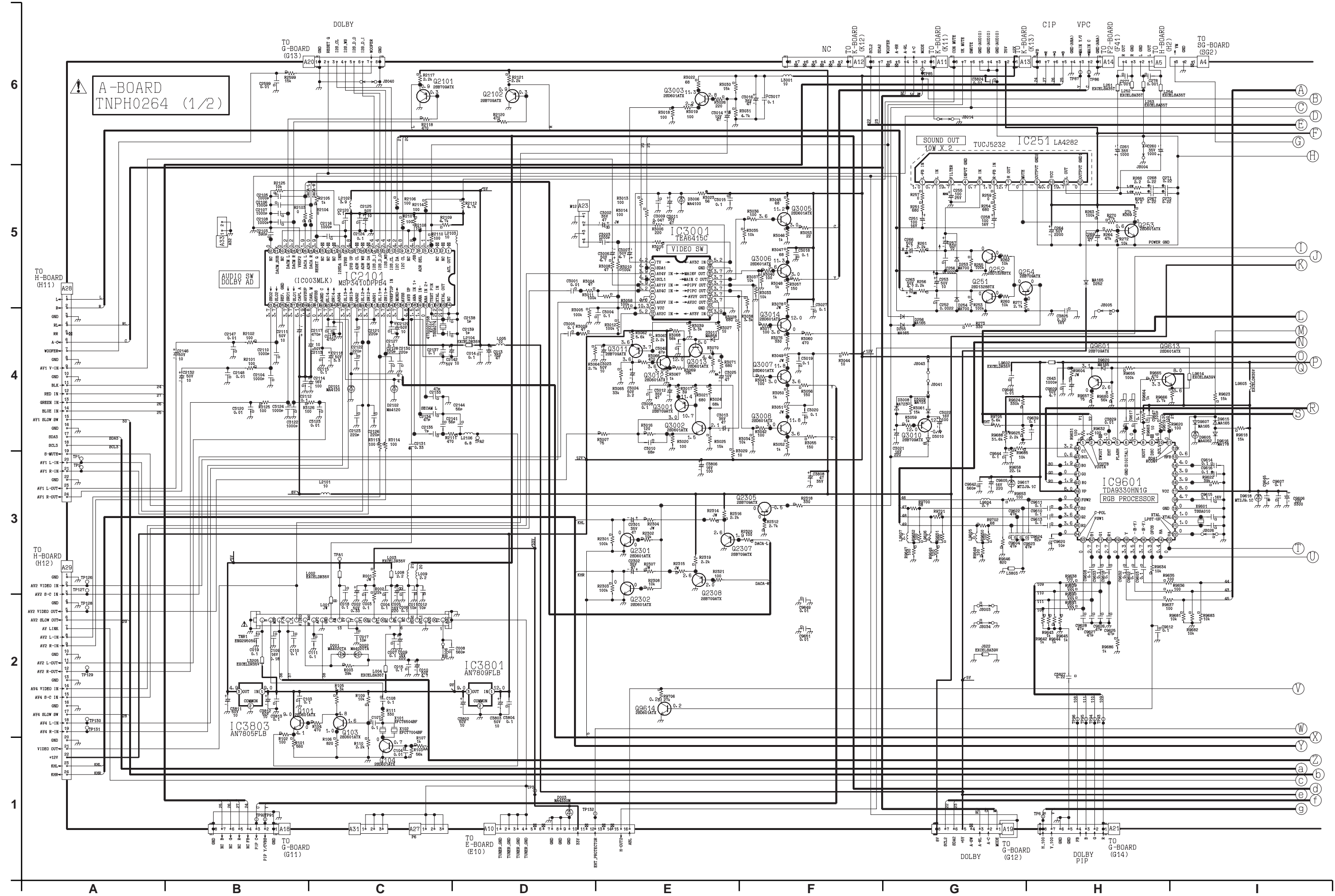

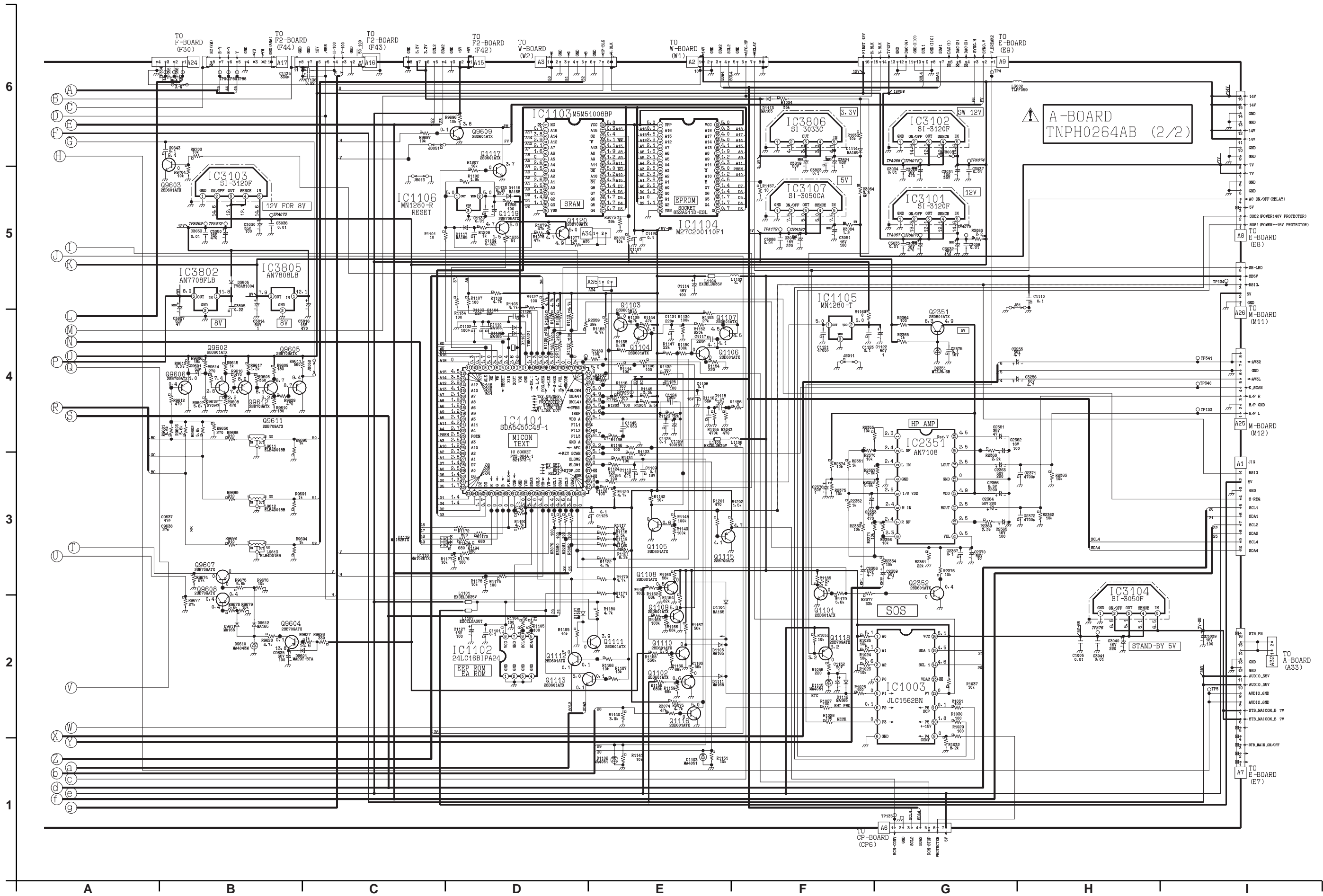

D-BOARD TNPA1338 (1/2)

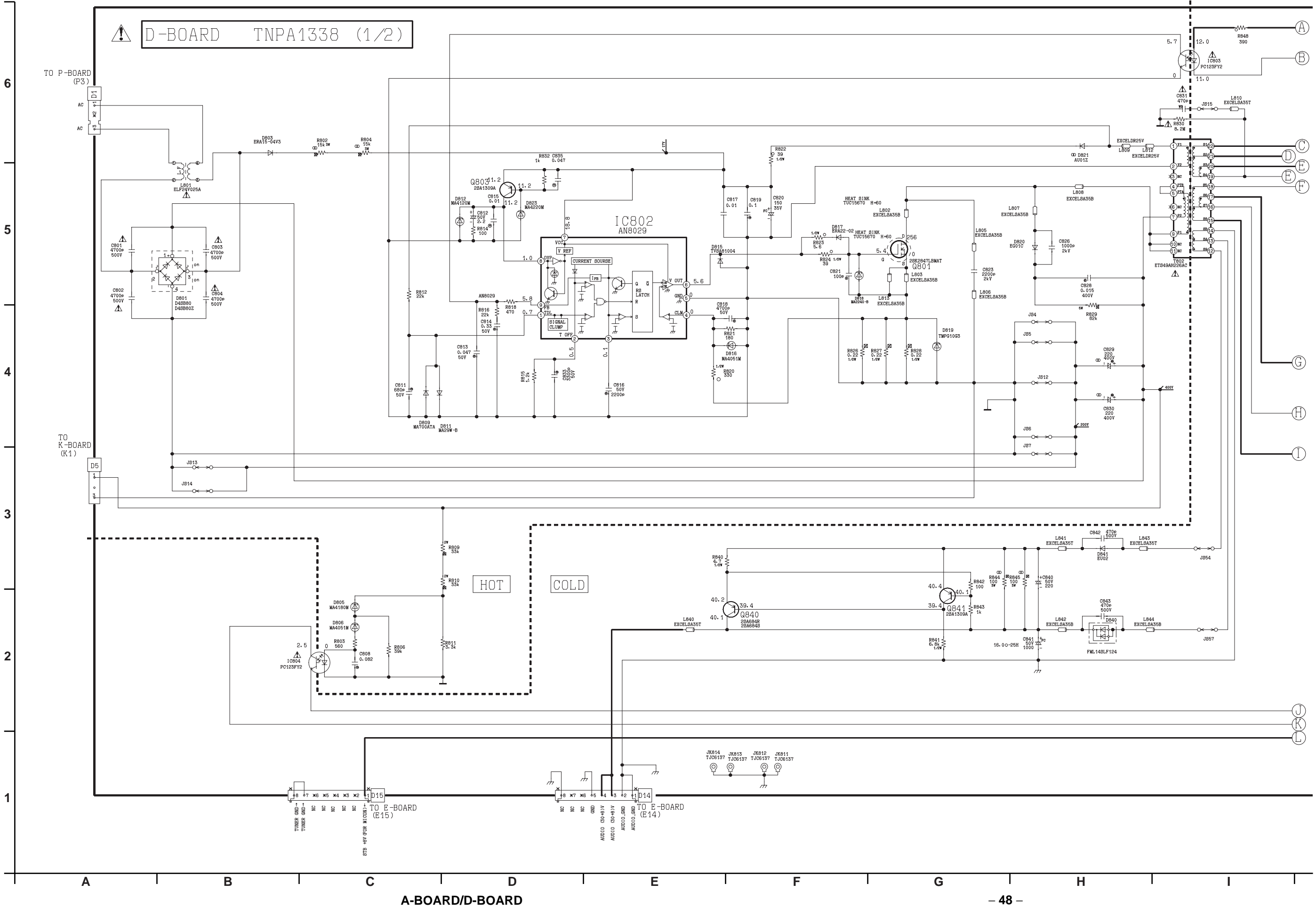

D-BOARD
TNPA1338 (2/2)

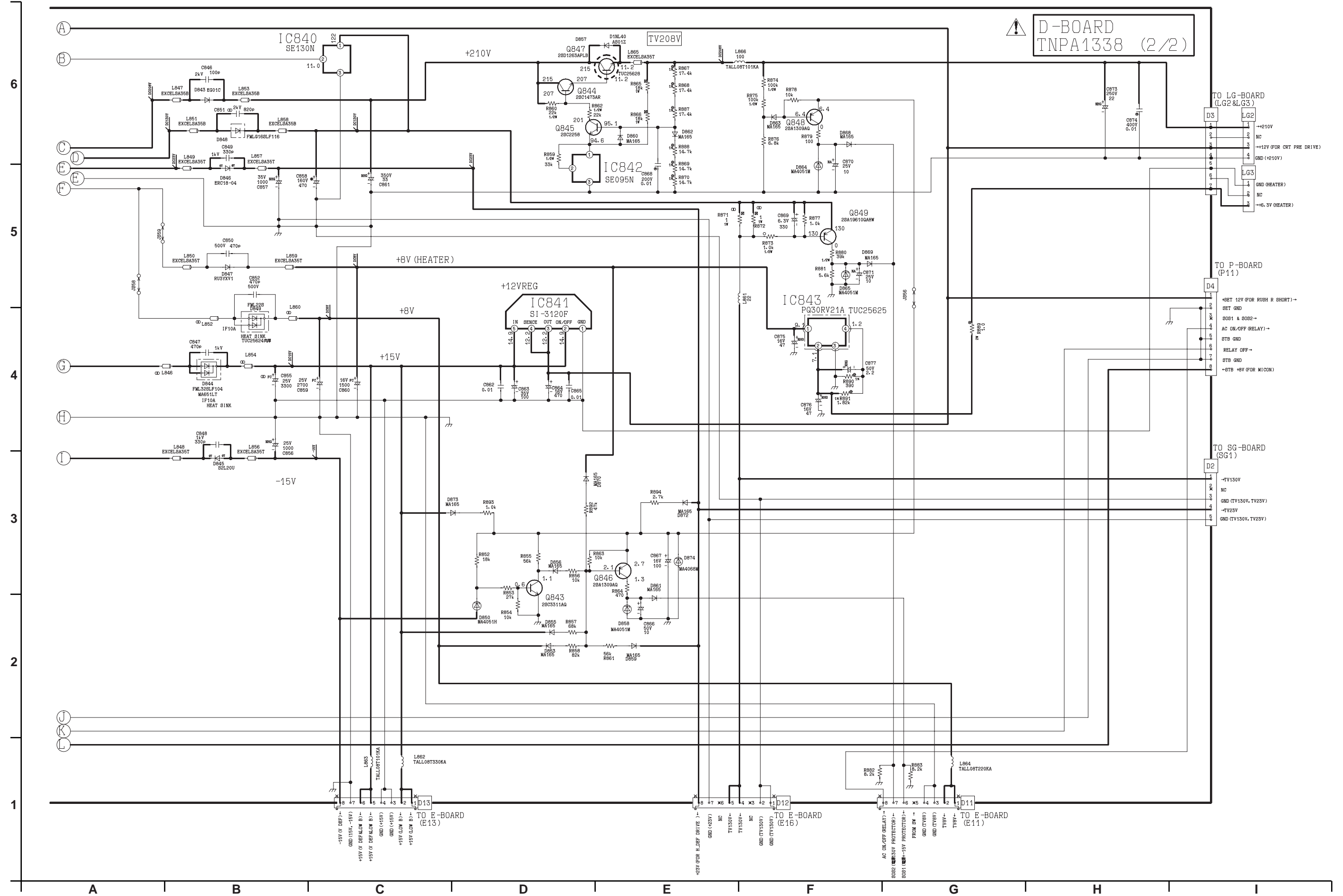

DC-BOARD TNPA1226AB (1/2)

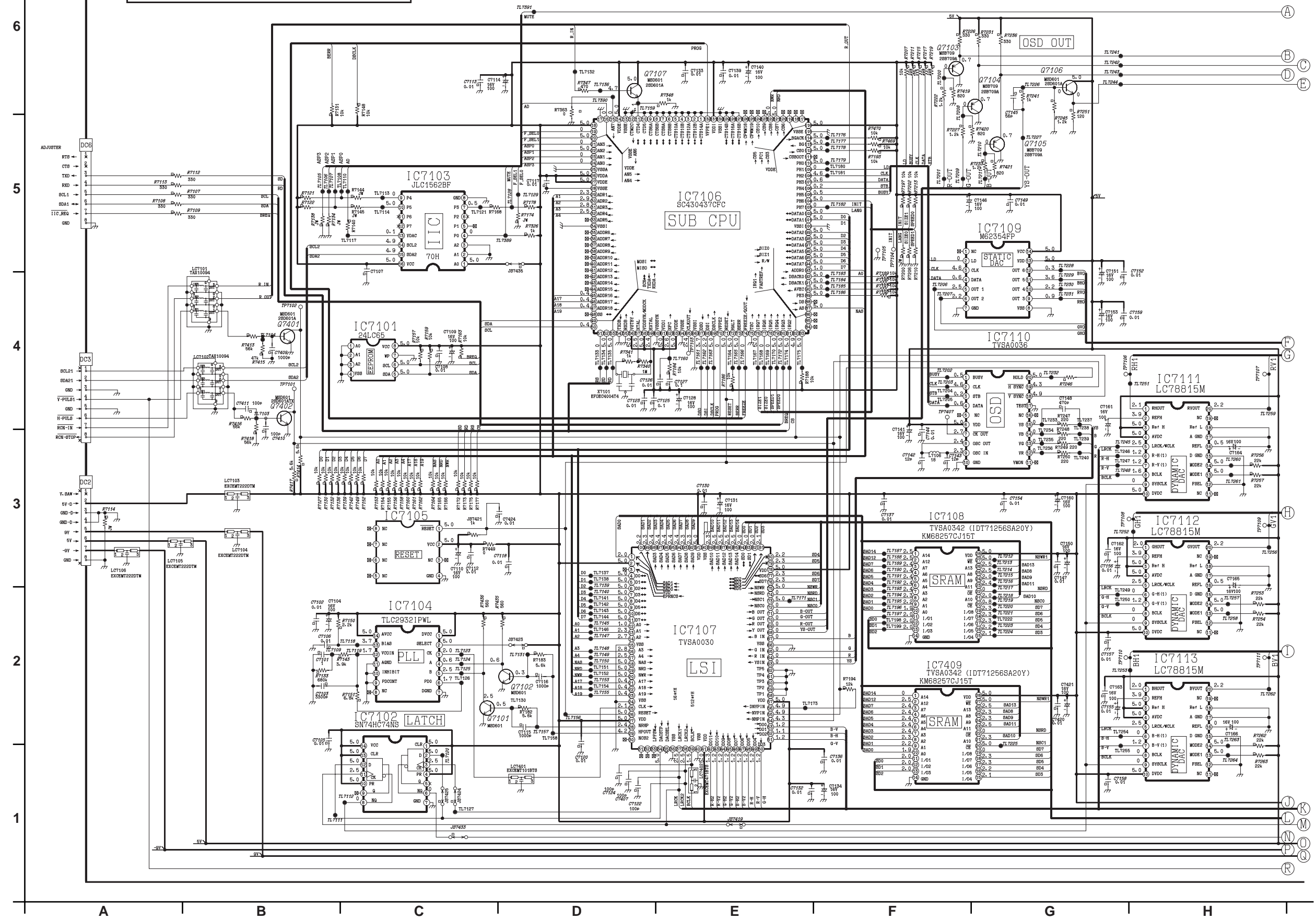

DC-BOARD TNPA1226AB (2/2)

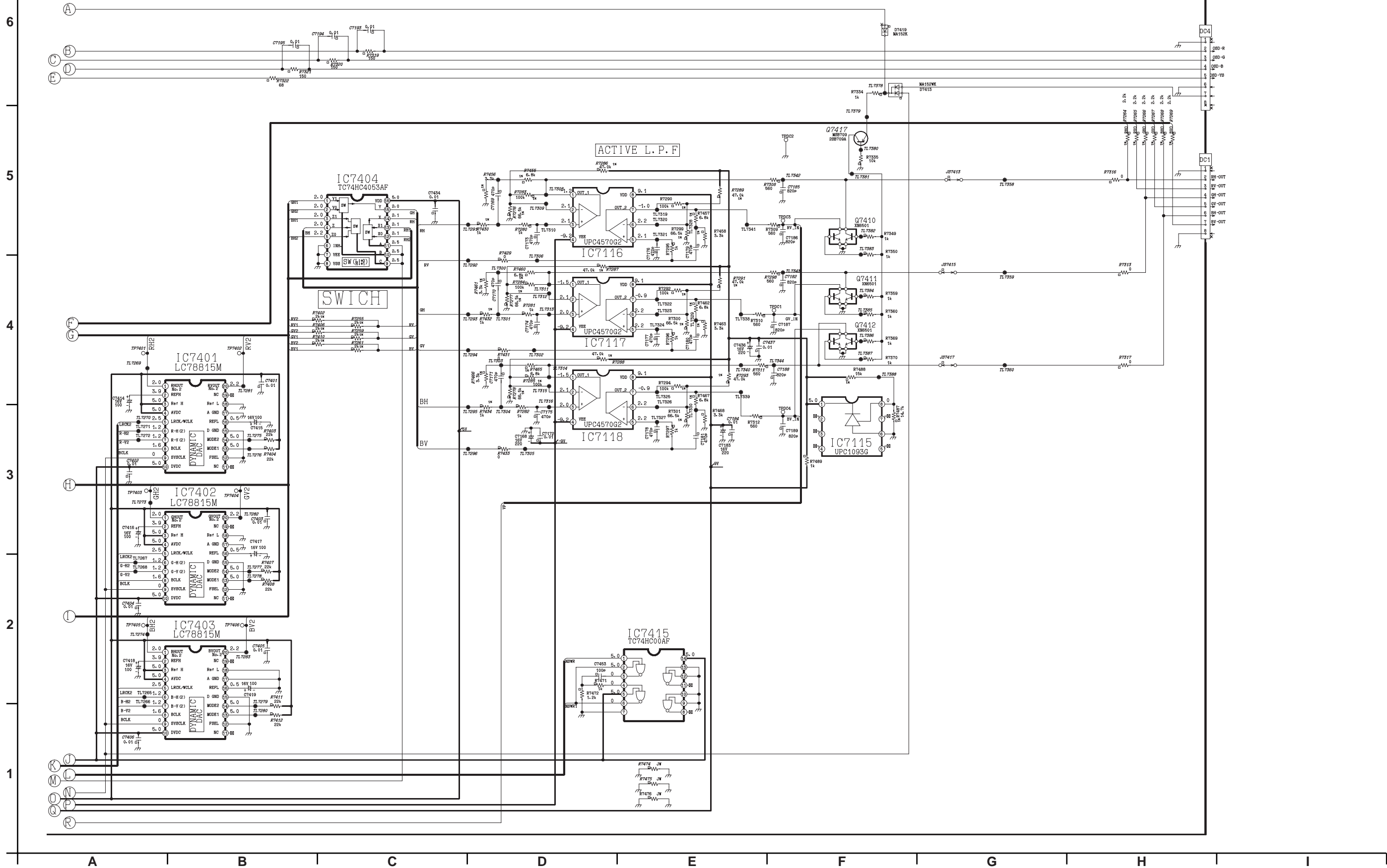

TX-47PT1F

TX-47PT1F

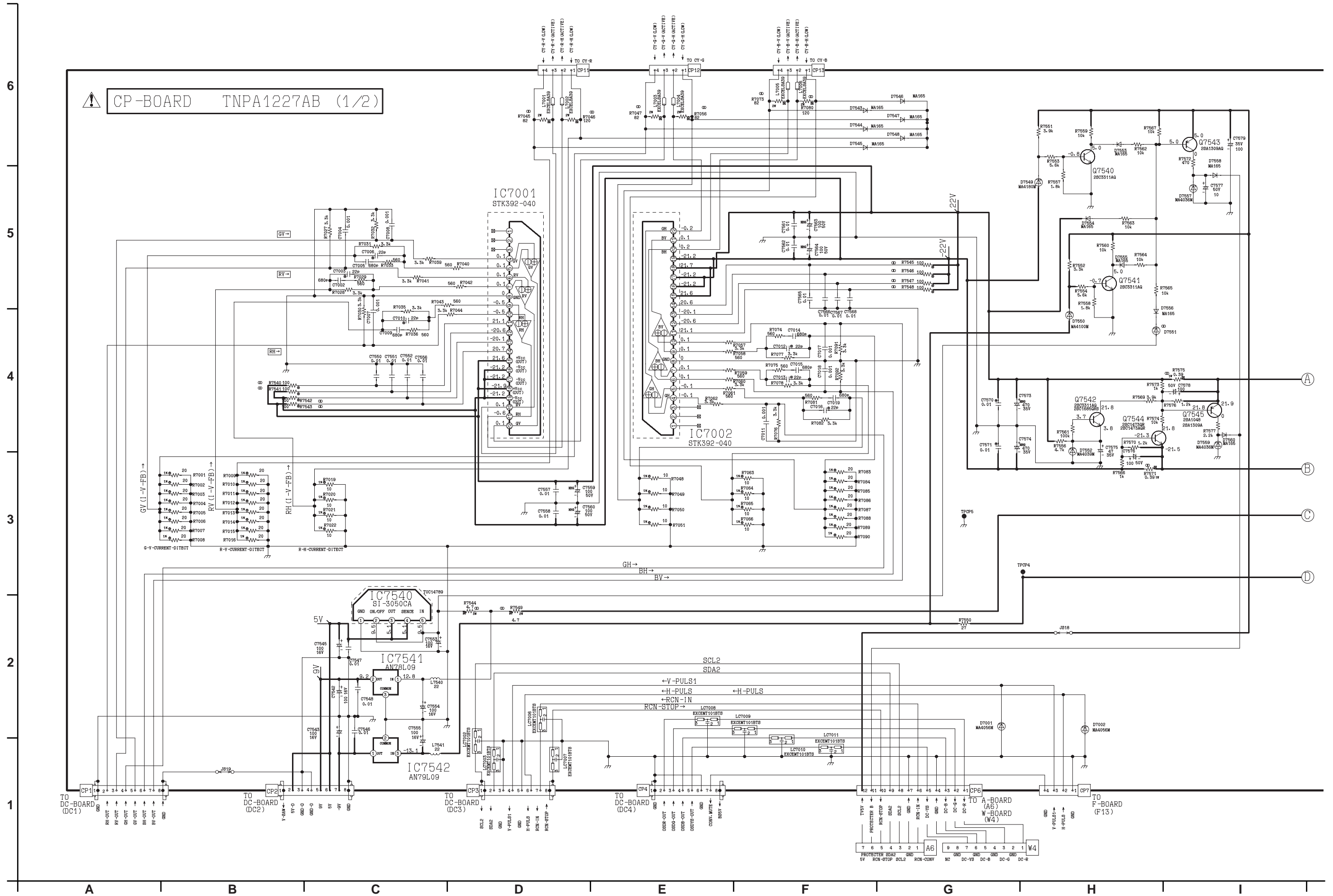

DC-BOARD/CP-BOARD

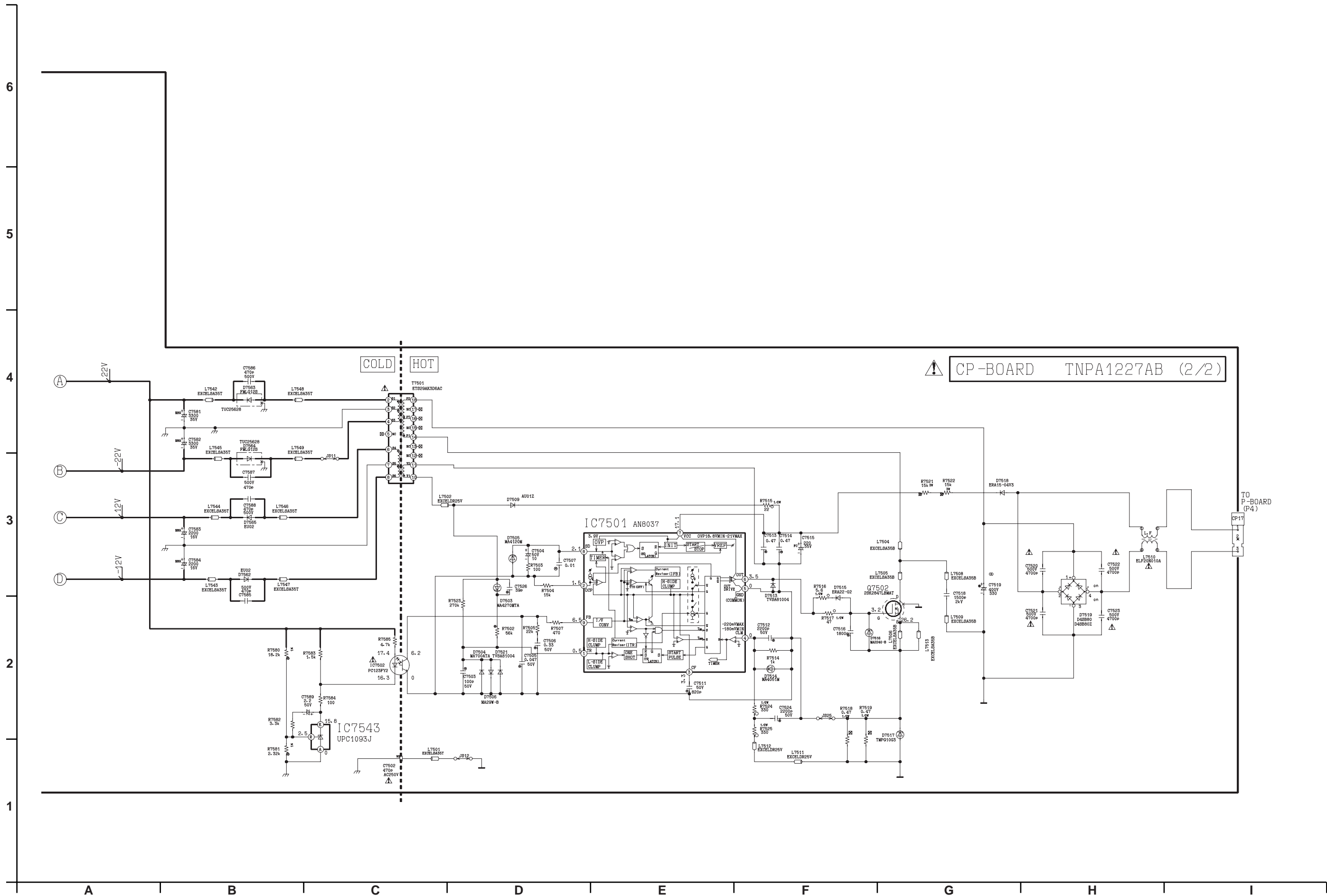

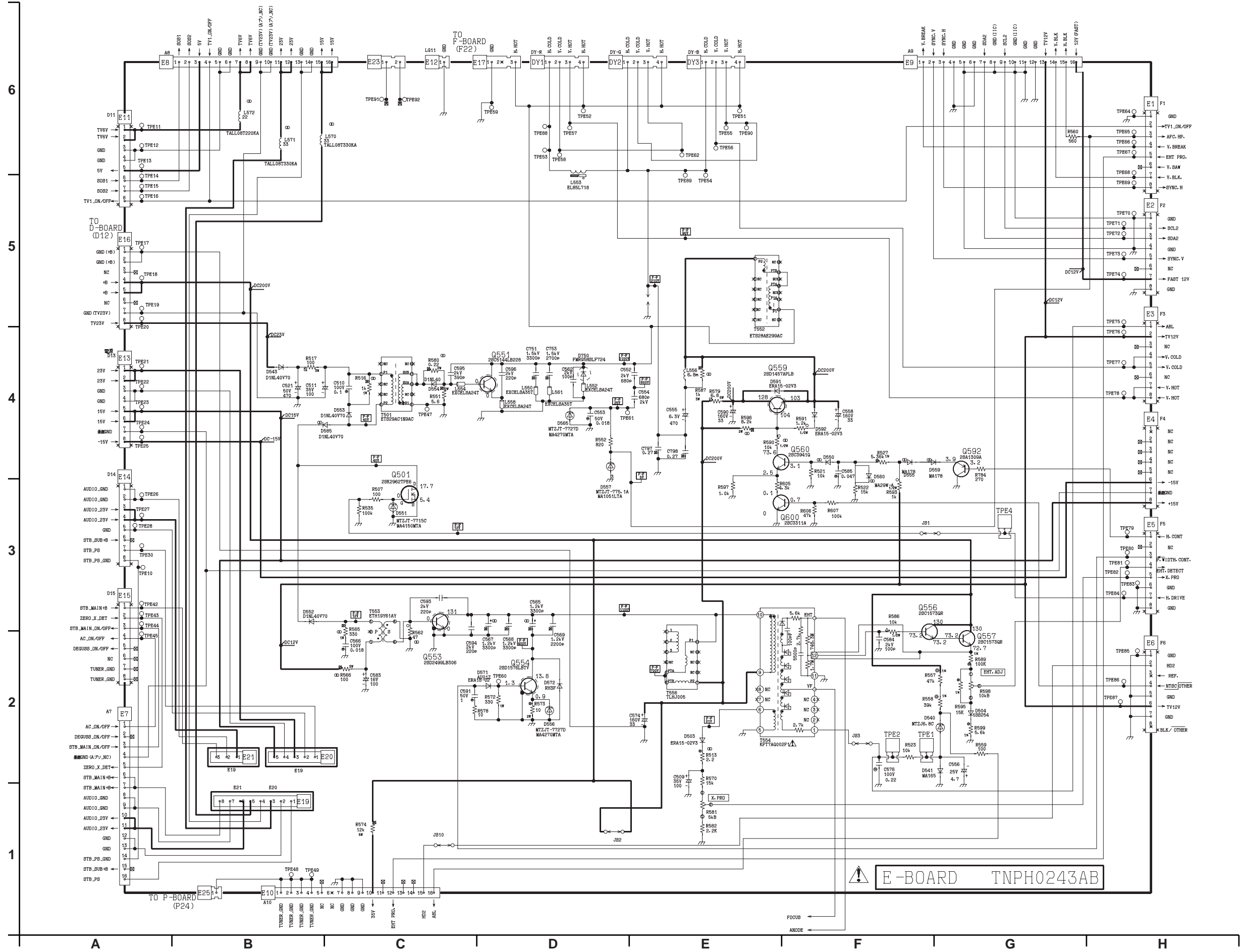

E-BOARD TNP0243AB

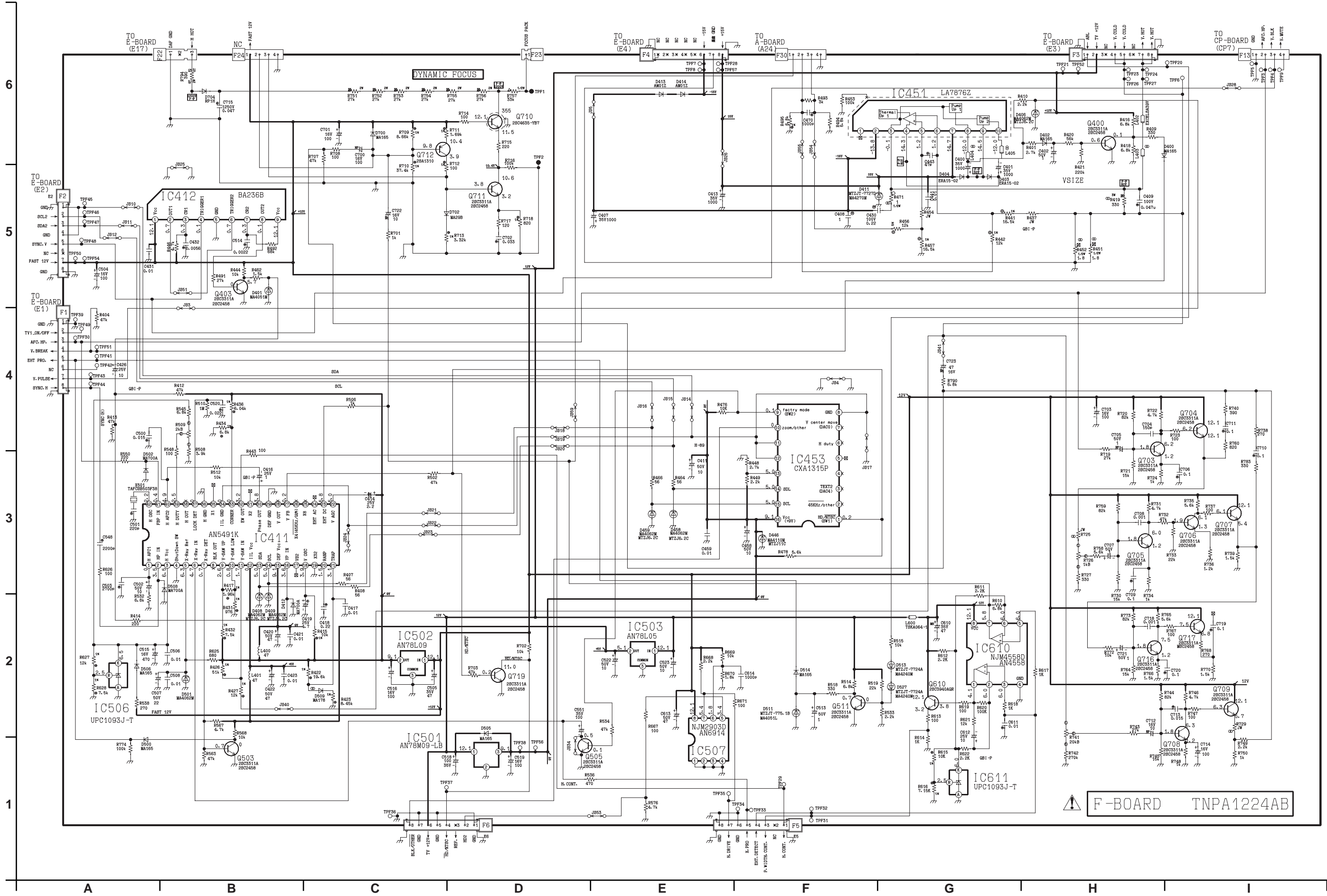

TX-47PT1F

TX-47PT1F

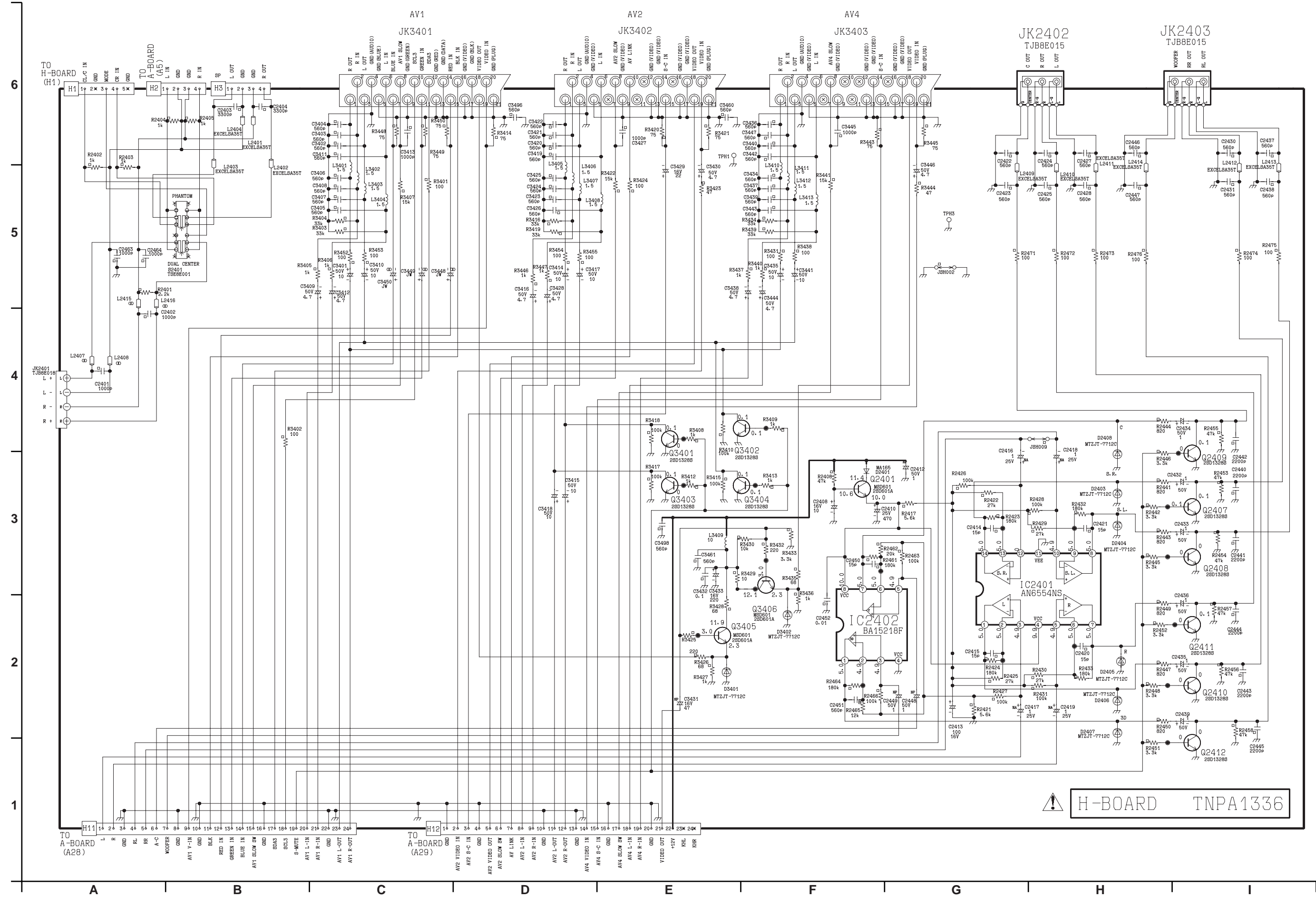

H-BOARD TNPA1336

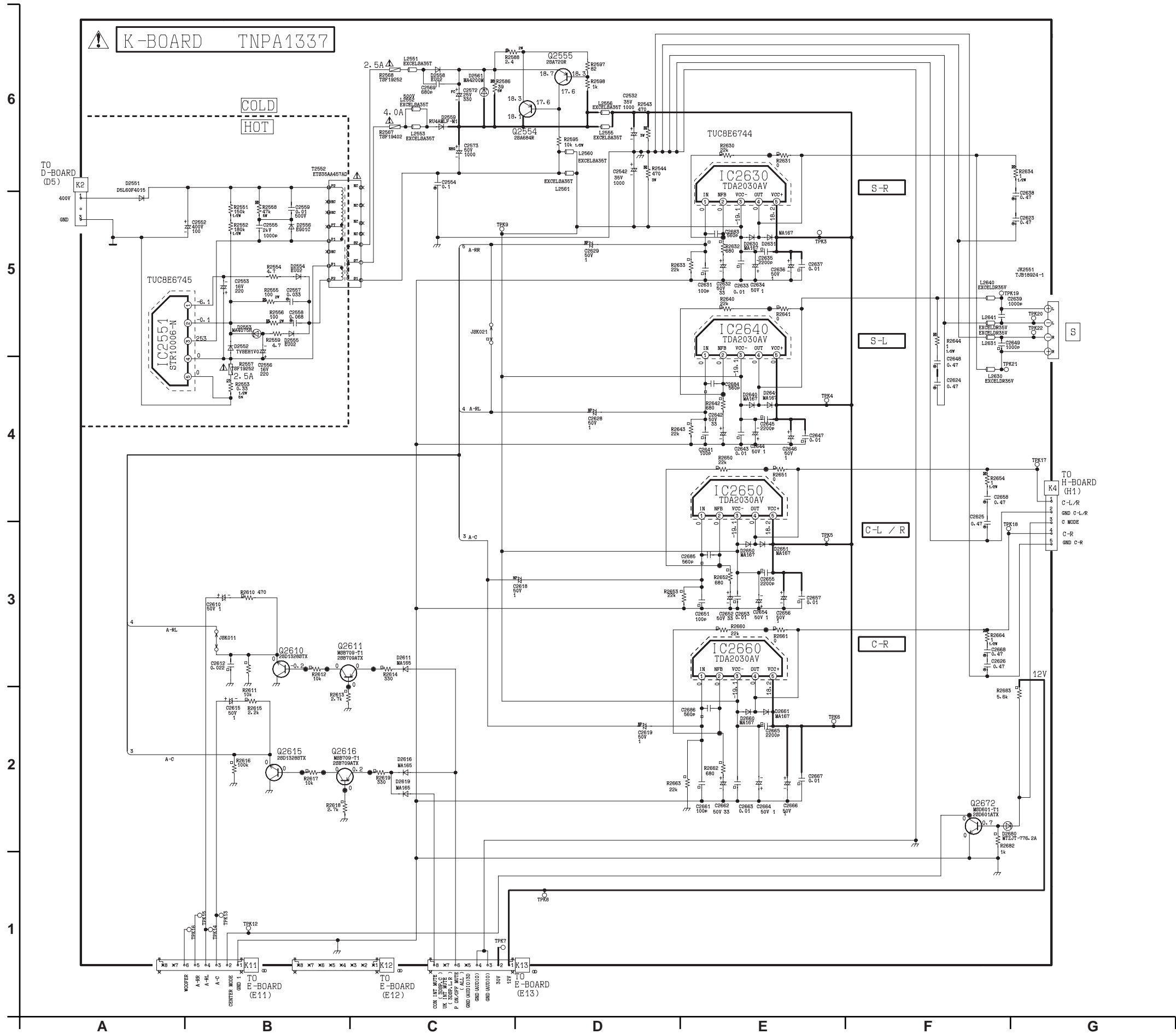

TX-47PT1F

TX-47PT1F

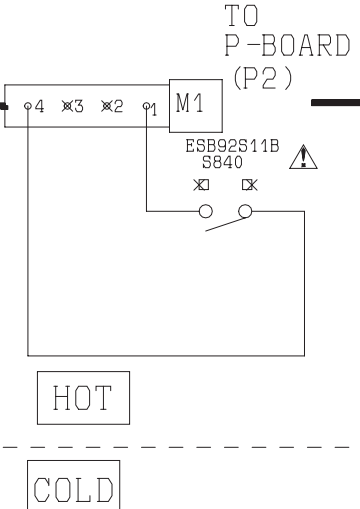
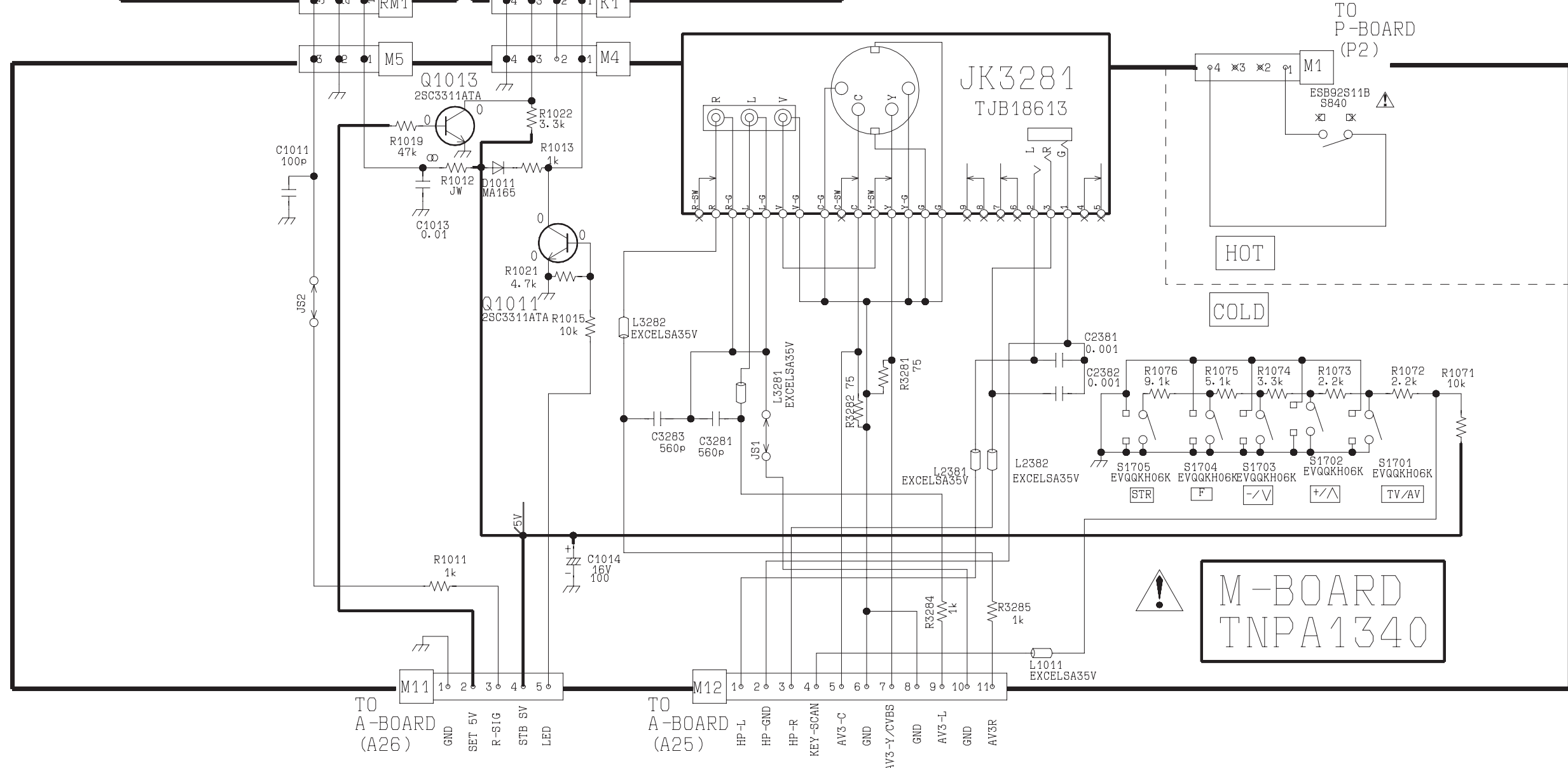
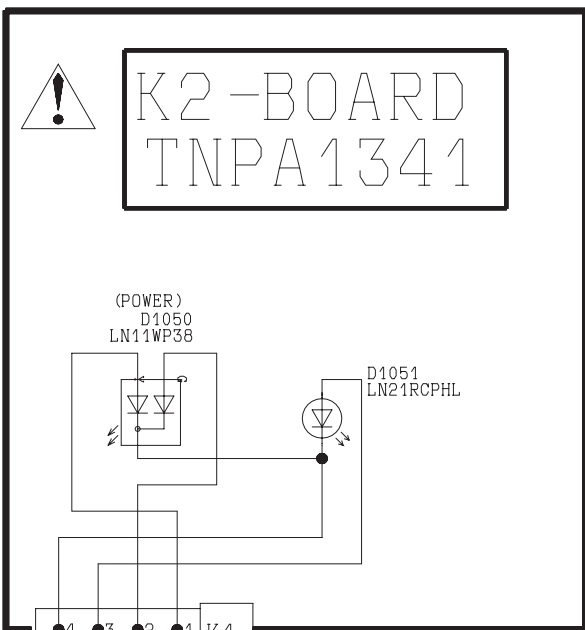
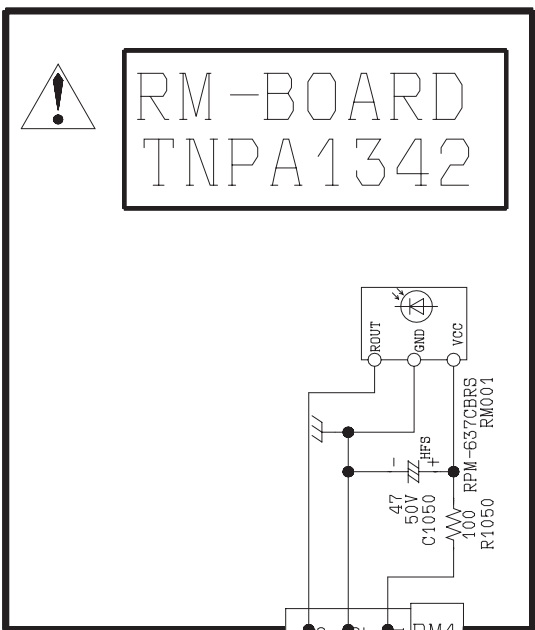

W-BOARD TNPA1431

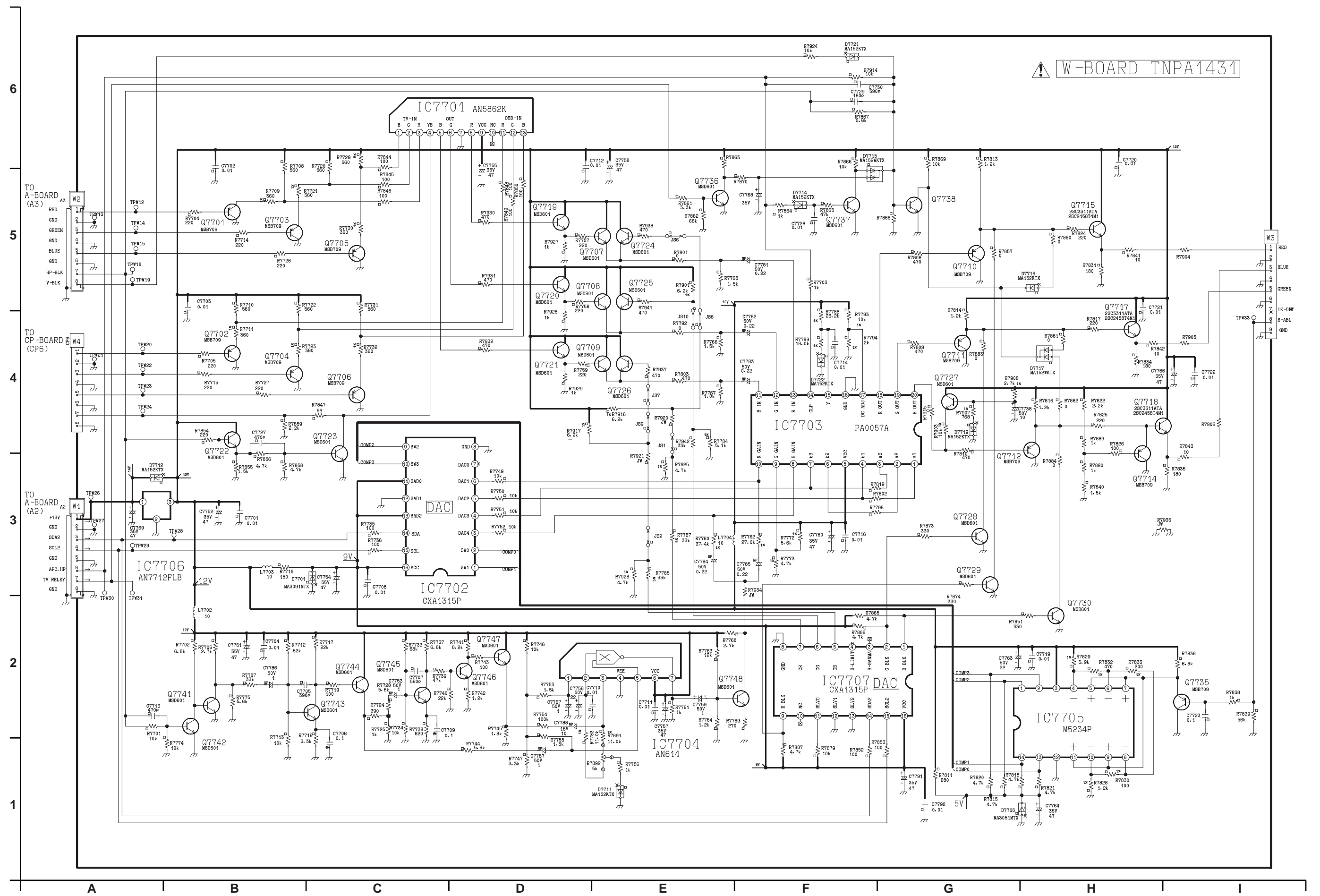

6
5
4
3
2
1



G-BOARD TNPA1335 (1/2)

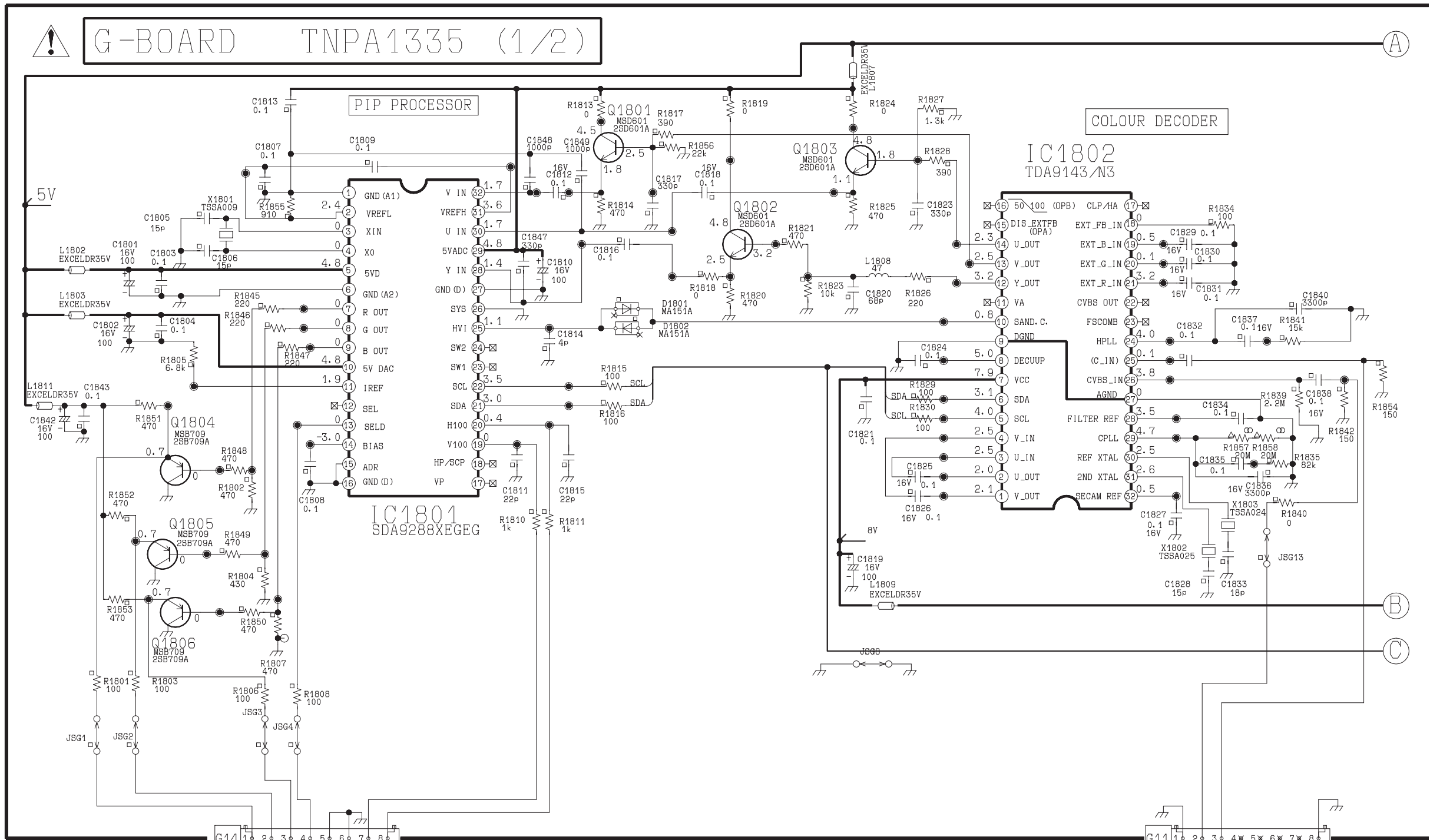

A B C D E F G H

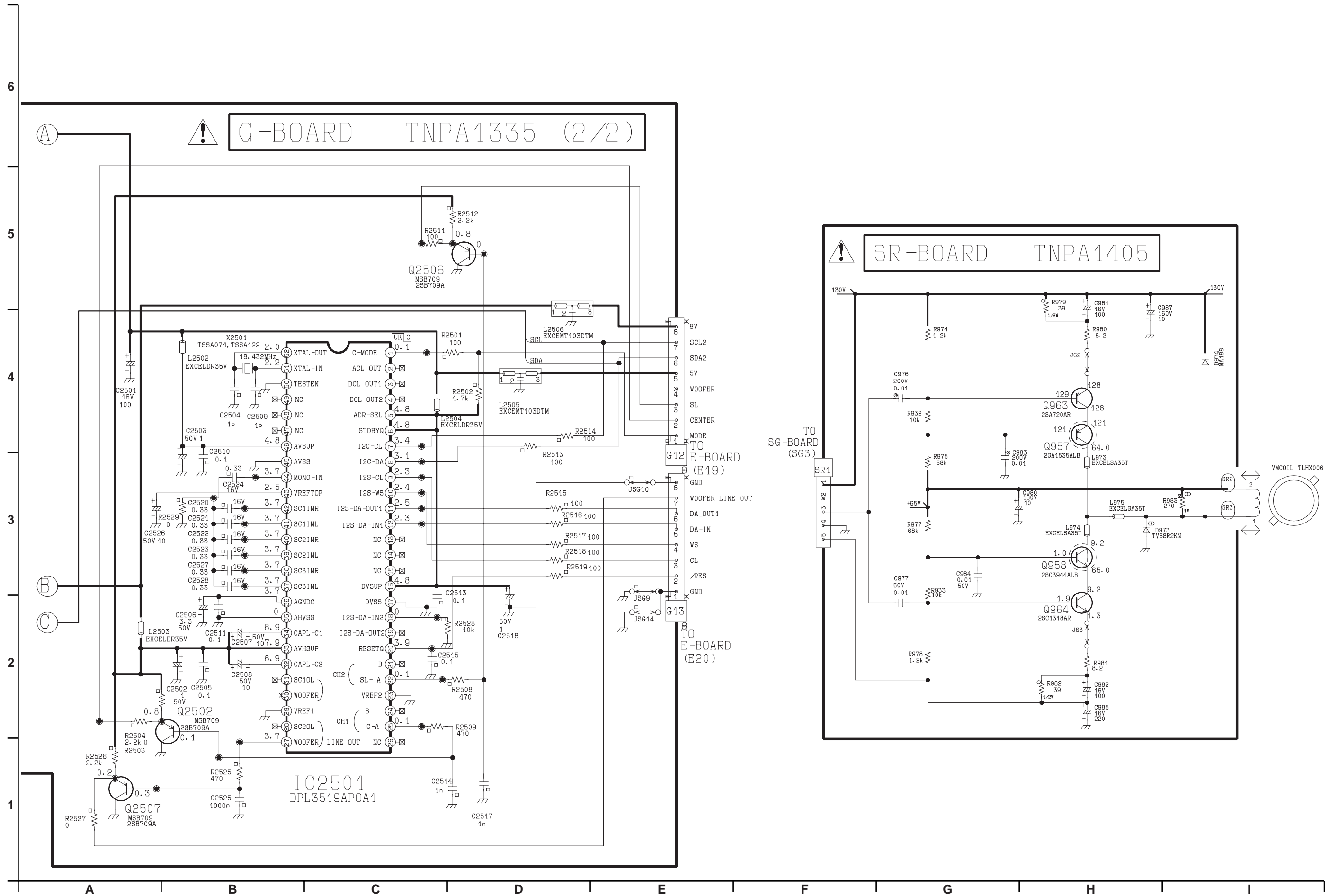

SG-BOARD TNPA1405

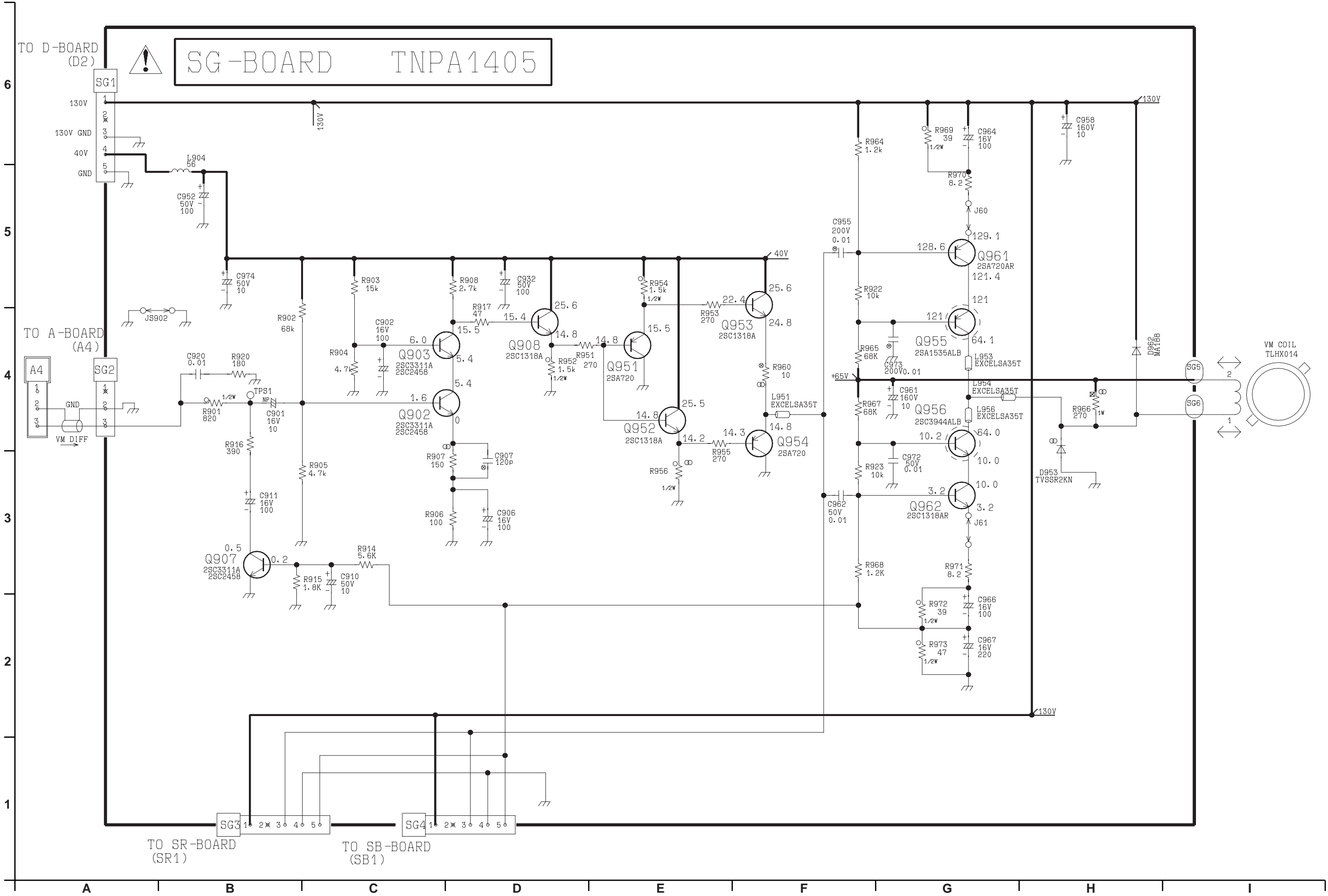

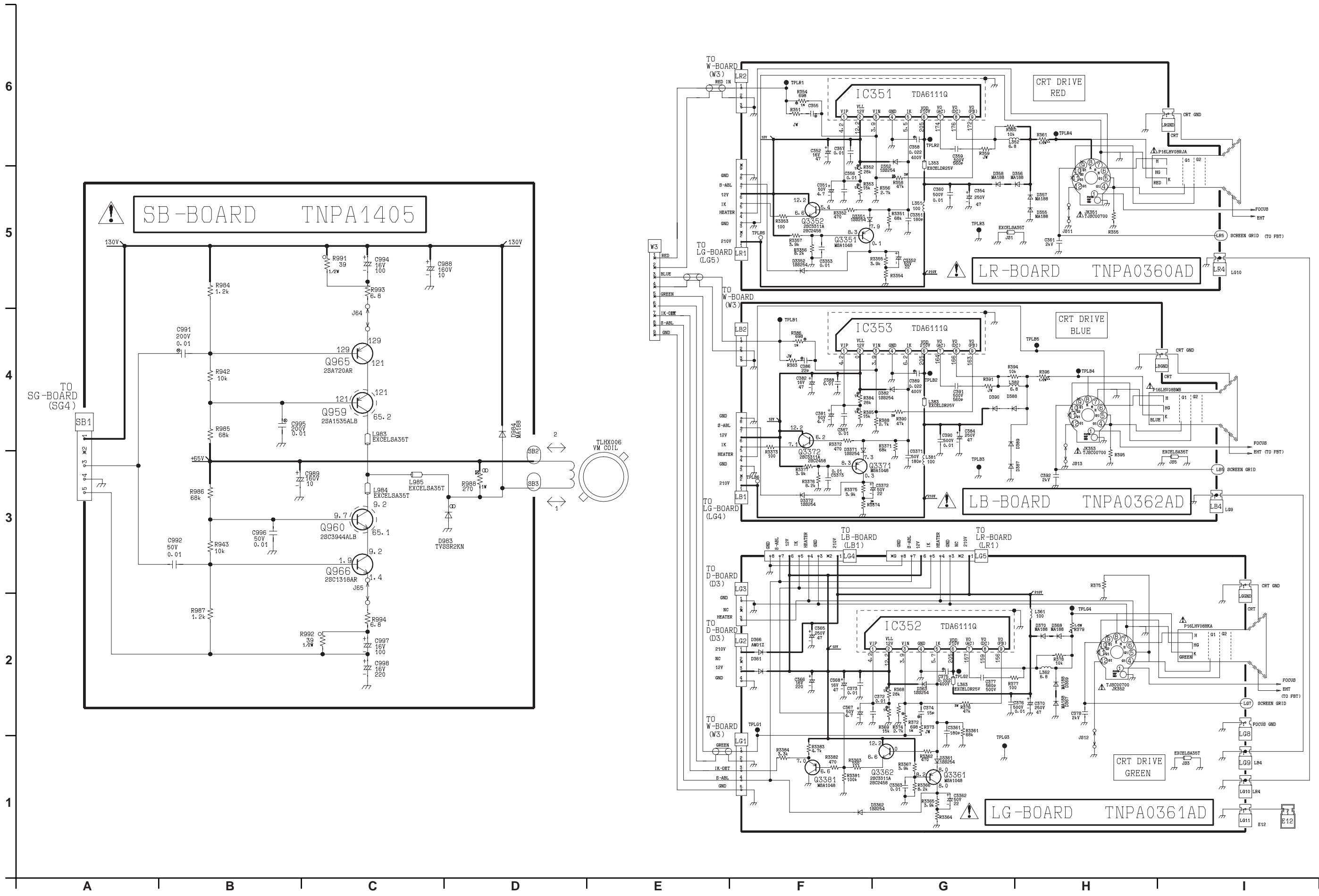

PARTS LOCATION & MECHANICAL REPLACEMENT PARTS LIST

Note: The number on mechanical parts indicates Ref. No. Mechanical Replacement Parts List.

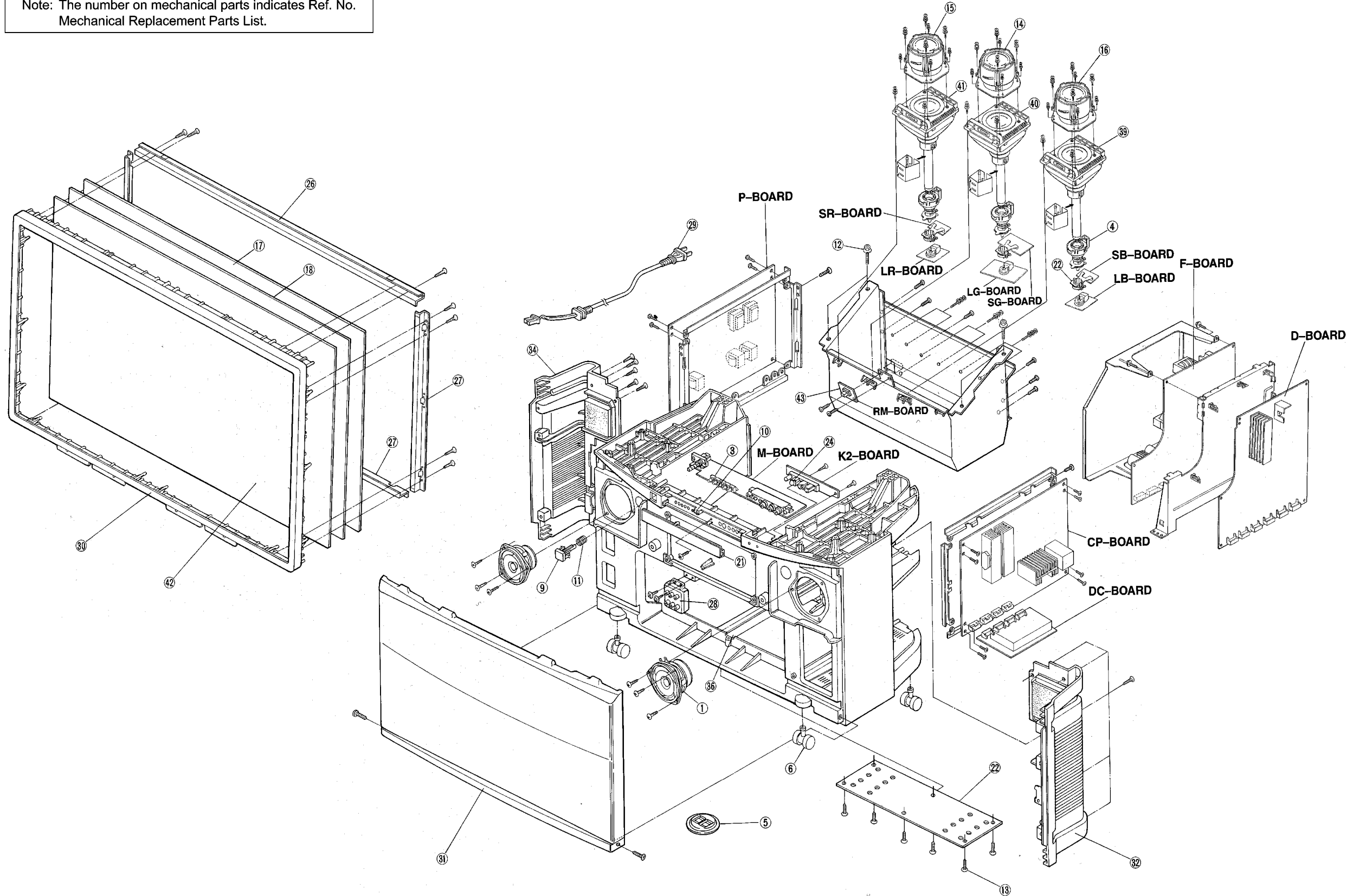

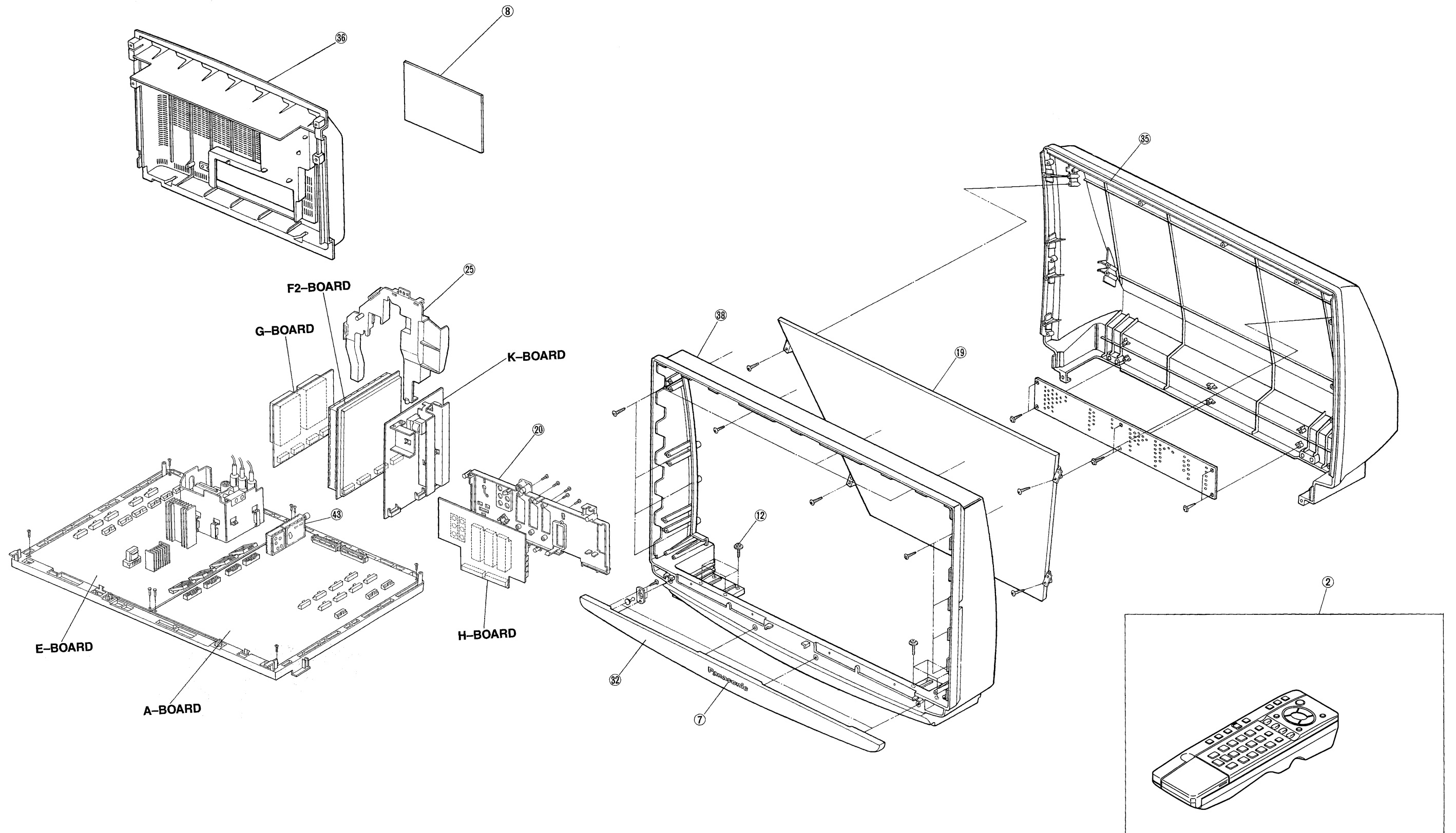

Replacement Parts List

Ref. No	Part No.	Description
MECHANICAL PARTS		
1	EAS12P481B	SPEAKER
2	EUR511220	TRANSMITTER
3	KBQ5350	SW CAP
△ 4	KDY2AS897F	DEFLECTION YOKE
	KRCBC160928B	CLAMPER
5	TBLB3008	CASTER BASE
6	TBL151908	CASTER
7	TBMA068	PANASONIC BADGE
8	TBMD390	MODEL NAME PLATE
9	TBX2684309	POWER BUTTON
10	TEK6935	DOOR SWITCH
	TESA031	SPRING
	TES1129	SPRING
	TES202	SPRING
11	TES2273	SPRING
	TES4156	SPRING
	TES4539	SPRING
	TES6162	SPRINGTR HOLD
	TES6583	SPRING FOR TR
	THEL018	SCREW
	THTA006Z	SCREW
	THTA011	SCREW
	THT1062	SCREW
	THT938-2	SCREW
	THT944-2	SCREW
14	TKGF0007	LENS (G)
15	TKGF0013	LENS (R)
16	TKGF0014	LENS (B)
17	TKGH5022	SCREEN
18	TKGH5036	SCREEN
19	TKGJ5012-1	MIRROR
20	TKPA29601	REAR BRACKET
21	TKPA30402	FRONT PANEL
22	TKZX5006	BOTTOM BOARD
23	TLHX014	VM COIL
	TMKX051	INSULATOR
	TMKX059	INSULATOR
	TMK23023	CLAMPER
	TMME031	SPACER
	TMME047	CLAMPER
	TMM14444	CLAMPER
	TMM15412-1	CLAMPER
	TMM16452	CLAMPER
	TMM16473-1	CLAMPER
	TMM16480-1	CLAMPER
	TMM16497-1	CLAMPER
	TMM17479	CLAMPER
	TMM27420	CLAMPER
	TMM27446	SPACER
	TMM6425-1	LEAD CLAMPER
	TMM6428-1	CLAMPER
	TMM6463-1	CLAMPER
	TMM6496-1	CLAMPER
	TMM7464-2	CRAMPER
	TMM76430-1	CLAMPER
24	TMWX002-1	LED HOLDER
	TMW15946	SPACER
25	TMXL008	ARM HOLDER
26	TMZM5009	SCREEN FRAME (TOP)
27	TMZM5010	SCREEN FRAME (BOTTOM, L, R)
△ 28	TNXB003	FOCUS BLOCK
	TPCA16104	CARTON BOX
	TPCA16201B	CRATON BOX (BOTTOM)
	TPDA0053	CUSHION (UPPER)
	TPDA0054-1	CUSHION (BOTTOM)
	TPDA0055	PAD
	TPDA0063	PAD
	TPDA0064	PAD
	TPDF0042	PAD
	TPDF0056	PAPER POLE

Ref. No	Part No.	Description
	TPDJ0008	CUSHION (FRONT/CENTER)
	TPD169487	JOINT
	TPD169564	JOINT
	TPEH033	PROTECT COVER
	TPEH081	SET COVER
	TPEH091	PROTECT COVER
	TPEX007	WASHING CLOTH
△	TQBC0121	INSTRUCTION BOOK(ENGLISH)
△	TQBC0122	INSTRUCTION BOOK(ENGLISH)
△	TQBC0123	INSTRUCTION BOOK(ENGLISH)
△	TQBC0124	INSTRUCTION BOOK(ENGLISH)
△	TQBC0125	INSTRUCTION BOOK(ENGLISH)
△	TQBC0126	INSTRUCTION BOOK(ENGLISH)
	TQZH098	CAUTION NOTE
△	29	TSXA116
	TSXA116	AC POWER CORD
	30	TTEA0020
	31	TTPA0104
	32	TTPA0106
	33	TTUA0032
△	34	TTUA0053
△	35	TTUA0150
△	36	TTUA0271
△	37	TTYA0299-1
	38	TTYA0363
	TUAA02102	CHASSIS GUIDE
	TUAA02901	GUIDE
	TUAA08101	CHASSIS GUIDE
39	TVVAB10EDZ	PICTURE TUBE (B)
40	TVVAG10EDZ	PICTURE TUBE (G)
41	TVVAR10EDZ	PICTURE TUBE (R)
42	TXFKG010BJZ	FRONT PANEL
△	TXF3F025MA	ANODE LEAD
△	TXF3F035MA	ANODE LEAD
	XTB4+10J	SCREW
	XTB4+15A	SCREW
	XTB4+15AFZ	SCREW
	XTB4+16J	SCREW
	XTB4+16JFZ	SCREW
	XTS3+12A	SCREW
	XTV3+10G	SCREW
	XTV3+12A	SCREW
	XTV3+12AFZ	SCREW
	XTV3+12G	SCREW
	XTV3+12GFZ	SCREW
	XTV3+16A	SCREW
	XTV3+16GFZ	SCREW
	XTV3+6J	SCREW
	XTV3+8J	SCREW
	XTW3+10T	SCREW
	XWC8B	WASHER
	XWG8	WASHER
	XYN4+F14	SCREW
	XYN4+J10FZ	SCREW
	XYN4+J8	SCREW
	XYN5+F12	SCREW
	XZBT6506	POLY BAG
43	RPM-637CBRS	REMOTE CONTROL RECIVER (RM001)
△ 44	ENG29505G	TUNER (TNR1)

Important Safety Notice

Components identified by Δ mark have special characteristics important for safety. When replacing any of these components, use only manufacturer's specified parts.

RTL (Retention Time Limited)

Note: The marking (RTL) indicates that the Retention Time is Limited for this item. After the discontinuation of this assembly in production, the item will continue to be available for a specific period of time. The retention period of availability is dependant on the type of assembly, and in accordance with the laws governing part and product retention. After the end of this period, the assembly will no longer be available.

Abbreviation of part name and description

1. Resistor

Example:

ERD25TJ104 \underline{C} 100KOHM, \underline{J} , 1/4W
 Type Allowance

2. Capacitor

Example:

ECKF1H103ZF \underline{C} 0.01UF, \underline{Z} , 50V
 Type Allowance

Type	Allowance
C : Carbon	F : ±1%
F : Fuse	G : ±2%
M : Metal Oxide Metal Film	J : ±5%
S : Solid	K : ±10%
W : Wire Wound	M : ±20%

Type	Allowance
C : Ceramic	C : ±0.25pF
E : Electrolytic	D : ±0.5pF
P : Polyester	F : ±1pF
Polypropylene	G : ±3pF
J : ±5pF	
T : Tantalum	K : ±10pF
	L : ±15pF
	M : ±20pF
	P : +100%, -0%
	Z : +80%, -20%

Ref. No	Part No.	Description	Ref. No	Part No.	Description
INTEGRATED CIRCUITS					
IC251	LA4282	LINEAR IC	IC7105	MC33064D-5R2	LINEAR IC
IC351	TDA6111Q	LINEAR IC	IC7106	SC430437CFC	IC
IC352	TDA6111Q	LINEAR IC	IC7107	TVSA0030	MOS IC (CMOS GATE ARRAY)
IC353	TDA6111Q	LINEAR IC	IC7108	TVSA0342	IC (SRAM)
IC411	AN5491K	LINEAR IC	IC7109	M62354FP	LINEAR IC
IC412	BA236B	LINEAR IC	IC7110	TVSA0036	MOS IC (LOGIC)
IC451	LA7876Z	LINEAR IC	IC7111	LC78815M	MOS IC (MICON LSI)
IC453	CXA1315P	LINEAR IC	IC7112	LC78815M	MOS IC (MICON LSI)
IC501	AN78M09	LINEAR IC	IC7113	LC78815M	MOS IC (MICON LSI)
IC502	AN78L09	LINEAR IC	IC7115	UPC1093G	LINEAR IC
IC503	AN78L05	LINEAR IC	IC7116	UPC4570G2	LINEAR IC
IC506	UPC1093J	LINEAR IC	IC7117	UPC4570G2	LINEAR IC
IC507	NJM2903D	LINEAR IC	IC7118	UPC4570G2	LINEAR IC
IC610	NJM4558D	LINEAR IC	IC7401	LC78815M	MOS IC (MICON LSI)
IC611	UPC1093J	LINEAR IC	IC7402	LC78815M	MOS IC (MICON LSI)
△ IC802	AN8029	LINEAR IC	IC7403	LC78815M	MOS IC (MICON LSI)
△ IC803	PC123FY2	PHOTO COUPLER	IC7404	TC74HC4053AF	MOS IC (CMOS S/LOGIC)
IC804	PC123FY2	PHOTO COUPLER	IC7409	TVSA0342	IC (SRAM)
IC840	SE130N	LINEAR IC	IC7415	TC74HC00AF	IC
IC841	SI-3120F	HYBRID IC	IC7501	AN8037	LINEAR IC
IC842	SE095N	LINEAR IC	△ IC7502	PC123FY2	PHOTO COUPLER
IC843	PQ30RV21A	LINEAR IC	IC7540	SI-3050CA	HYBRID IC
IC1003	JLC1562BN	MOS IC (MICON LSI)	IC7541	AN78L09	LINEAR IC
IC1101	SDA5450C48-1	IC	IC7542	AN79L09	LINEAR IC
IC1101S	TJSB01284	IC SOCKET	IC7543	UPC1093J	LINEAR IC
IC1102	TVRJ221-1	ROM IC (EEPROM)	IC7701	AN5862K	LINEAR IC
IC1103	M5M51008BP	IC	IC7702	CXA1315P	LINEAR IC
IC1104S	TJS1A2410	IC SOCKET	IC7703	PA0057A	LINEAR IC
IC1104	TVRJ218-1	ROM IC	IC7704	AN614	LINEAR IC
IC1105	MN1280T	MOS IC	IC7705	M5234P	LINEAR IC
IC1106	MN1280R	MOS IC (MICON LSI)	IC7706	AN7712F	LINEAR IC
IC1502	VPC3215CB4TP	IC (CMOS GATE ARRAY)	IC7707	CXA1315P	LINEAR IC
IC1503	MB87F1720	IC (CMOS GATE ARRAY)	IC9601	TDA9330HN1G	LINEAR IC
IC1504	FJB007S	IC (CMOS GATE ARRAY)	TRANSISTORS		
IC1505	MB87F2131	IC	Q101	2SD601A	TRANSISTOR
IC1506	AN77L035M	LINEAR IC	Q103	2SD601A	TRANSISTOR
IC1507	MB87H2010	IC	Q104	2SD601A	TRANSISTOR
IC1509	TLC2932IPWL	LINEAR IC	Q251	2SD1328	TRANSISTOR
IC1510	MB87F1720	IC (CMOS GATE ARRAY)	Q252	2SD1328	TRANSISTOR
IC1801	SDA9288XEGEG	IC	Q253	2SD601A	TRANSISTOR
IC1802	TDA9143/N3	LINEAR IC	Q254	2SB709A	TRANSISTOR
IC2101	MSP3410DPPB4	IC	Q400	2SC3311A	TRANSISTOR
IC2351	AN7108	LINEAR IC	Q403	2SC3311A	TRANSISTOR
IC2401	AN6554NSF	LINEAR IC	Q501	2SK2962	FET
IC2402	BA15218F	LINEAR IC	Q503	2SC3311A	TRANSISTOR
IC2501	DPL3519AP0A1	IC	Q505	2SC3311A	TRANSISTOR
IC2551	STR10006-N	IC	Q511	2SC3311A	TRANSISTOR
IC2630	TDA2030AV	IC	Q551	2SC5144	TRANSISTOR
IC2640	TDA2030AV	IC	Q553	2SD2499	TRANSISTOR
IC2650	TDA2030AV	IC	Q554	2SD1576TV	TRANSISTOR
IC2660	TDA2030AV	IC	Q556	2SC1573-Q	TRANSISTOR
IC3001	TEA6415C	IC	Q557	2SC1573-Q	TRANSISTOR
IC3101	SI-3120F	HYBRID IC	Q559	2SD1457A	TRANSISTOR
IC3102	SI-3120F	HYBRID IC	Q560	2SC3941	TRANSISTOR
IC3103	SI-3120F	HYBRID IC	Q592	2SA1309A	TRANSISTOR
IC3104	SI-3050F	HYBRID IC	Q600	2SC3311A	TRANSISTOR
IC3107	SI-3050CA	HYBRID IC	Q610	2SC3940A	TRANSISTOR
IC3801	AN7809F	LINEAR IC	Q703	2SC3311A	TRANSISTOR
IC3802	AN7708F	LINEAR IC	Q704	2SC3311A	TRANSISTOR
IC3803	AN7805F	LINEAR IC	Q705	2SC3311A	TRANSISTOR
IC3805	AN7808	LINEAR IC	Q706	2SC3311A	TRANSISTOR
IC3806	SI-3033C	HYBRID IC	Q707	2SC3311A	TRANSISTOR
IC6701	MIP2810001TV	IC (LOGIC)	Q708	2SC3311A	TRANSISTOR
△ IC6702	PC123FY2	PHOTO COUPLER	Q709	2SC3311A	TRANSISTOR
IC7001	STK392-040	LINEAR IC	Q710	2SC4635	TRANSISTOR
IC7002	STK392-040	LINEAR IC	Q711	2SC3311A	TRANSISTOR
IC7101	TVRJ224	ROM IC (EEPROM)	Q712	2SA1310	TRANSISTOR
IC7102	SN74HC74NS	MOS IC (CMOS S/LOGIC)	Q716	2SC3311A	TRANSISTOR
IC7103	JLC1562BF	MOS IC (MICON LSI)	Q717	2SC3311A	TRANSISTOR
IC7104	TLC2932IPWL	LINEAR IC			

Ref. No	Part No.	Description
Q719	2SC3311A	TRANSISTOR
Q801	2SK2847	FET
Q803	2SA1309A	TRANSISTOR
Q840	2SA684	TRANSISTOR
Q841	2SA1309A	TRANSISTOR
Q843	2SC3311A	TRANSISTOR
Q844	2SC1473A	TRANSISTOR
Q845	2SC2258	TRANSISTOR
Q846	2SA1309A	TRANSISTOR
Q847	2SD1263A	TRANSISTOR
Q848	2SA1309A	TRANSISTOR
Q849	2SA19610Q0HW	TRANSISTOR
Q902	2SC3311A	TRANSISTOR
Q903	2SC3311A	TRANSISTOR
Q907	2SC3311A	TRANSISTOR
Q908	2SC1318A	TRANSISTOR
Q951	2SA720-R	TRANSISTOR
Q952	2SC1318A	TRANSISTOR
Q953	2SC1318A	TRANSISTOR
Q954	2SA720-R	TRANSISTOR
Q955	2SA1535A	TRANSISTOR
Q956	2SC3944A	TRANSISTOR
Q957	2SA1535A	TRANSISTOR
Q958	2SC3944A	TRANSISTOR
Q959	2SA1535A	TRANSISTOR
Q960	2SC3944A	TRANSISTOR
Q961	2SA720A	TRANSISTOR
Q962	2SC1318A	TRANSISTOR
Q963	2SA720A	TRANSISTOR
Q964	2SC1318A	TRANSISTOR
Q965	2SA720A	TRANSISTOR
Q966	2SC1318A	TRANSISTOR
Q1011	2SC3311A	TRANSISTOR
Q1013	2SC3311A	TRANSISTOR
Q1101	2SD601A	TRANSISTOR
Q1102	2SD601A	TRANSISTOR
Q1103	2SD601A	TRANSISTOR
Q1104	2SD601A	TRANSISTOR
Q1105	2SD601A	TRANSISTOR
Q1106	2SD601A	TRANSISTOR
Q1107	2SD601A	TRANSISTOR
Q1108	2SD601A	TRANSISTOR
Q1109	2SD601A	TRANSISTOR
Q1110	2SD601A	TRANSISTOR
Q1111	2SD601A	TRANSISTOR
Q1112	2SD601A	TRANSISTOR
Q1113	2SD601A	TRANSISTOR
Q1115	2SB709A	TRANSISTOR
Q1116	2SD601A	TRANSISTOR
Q1117	2SD601A	TRANSISTOR
Q1118	2SB709A	TRANSISTOR
Q1119	2SB709A	TRANSISTOR
Q1120	2SB709A	TRANSISTOR
Q1501	2SB709A	TRANSISTOR
Q1502	2SB709A	TRANSISTOR
Q1503	2SD601A	TRANSISTOR
Q1504	2SD601A	TRANSISTOR
Q1505	2SD601A	TRANSISTOR
Q1506	2SD601A	TRANSISTOR
Q1507	2SD601A	TRANSISTOR
Q1508	2SD601A	TRANSISTOR
Q1509	2SD601A	TRANSISTOR
Q1510	2SD601A	TRANSISTOR
Q1511	2SD601A	TRANSISTOR
Q1513	2SB709A	TRANSISTOR
Q1660	2SD601A	TRANSISTOR
Q1661	2SD601A	TRANSISTOR
Q1662	2SD601A	TRANSISTOR
Q1663	2SD601A	TRANSISTOR
Q1664	2SD601A	TRANSISTOR

Ref. No	Part No.	Description
Q1665	2SD601A	TRANSISTOR
Q1666	2SD601A	TRANSISTOR
Q1667	2SD601A	TRANSISTOR
Q1801	2SD601A	TRANSISTOR
Q1802	2SD601A	TRANSISTOR
Q1803	2SD601A	TRANSISTOR
Q1804	2SB709A	TRANSISTOR
Q1805	2SB709A	TRANSISTOR
Q1806	2SB709A	TRANSISTOR
Q2101	2SB709A	TRANSISTOR
Q2102	2SB709A	TRANSISTOR
Q2301	2SD601A	TRANSISTOR
Q2302	2SD601A	TRANSISTOR
Q2305	2SB709A	TRANSISTOR
Q2307	2SB709A	TRANSISTOR
Q2308	2SB709A	TRANSISTOR
Q2351	2SD601A	TRANSISTOR
Q2352	2SD601A	TRANSISTOR
Q2401	2SD601A	TRANSISTOR
Q2407	2SD1328	TRANSISTOR
Q2408	2SD1328	TRANSISTOR
Q2409	2SD1328	TRANSISTOR
Q2410	2SD1328	TRANSISTOR
Q2411	2SD1328	TRANSISTOR
Q2412	2SD1328	TRANSISTOR
Q2502	2SB709A	TRANSISTOR
Q2506	2SB709A	TRANSISTOR
Q2507	2SB709A	TRANSISTOR
Q2554	2SA684	TRANSISTOR
Q2555	2SA720	TRANSISTOR
Q2610	2SD1328	TRANSISTOR
Q2611	2SB709A	TRANSISTOR
Q2615	2SD1328	TRANSISTOR
Q2616	2SB709A	TRANSISTOR
Q2672	2SD601A	TRANSISTOR
Q3001	2SB709A	TRANSISTOR
Q3002	2SD601A	TRANSISTOR
Q3003	2SD601A	TRANSISTOR
Q3005	2SD601A	TRANSISTOR
Q3006	2SD601A	TRANSISTOR
Q3007	2SD601A	TRANSISTOR
Q3008	2SD601A	TRANSISTOR
Q3010	2SB709A	TRANSISTOR
Q3011	2SB709A	TRANSISTOR
Q3012	2SD601A	TRANSISTOR
Q3013	2SD601A	TRANSISTOR
Q3014	2SD601A	TRANSISTOR
Q3351	2SA1309A	TRANSISTOR
Q3352	2SC3311A	TRANSISTOR
Q3361	2SA1309A	TRANSISTOR
Q3362	2SC3311A	TRANSISTOR
Q3371	2SA1309A	TRANSISTOR
Q3372	2SC3311A	TRANSISTOR
Q3381	2SA1309A	TRANSISTOR
Q3401	2SD1328	TRANSISTOR
Q3402	2SD1328	TRANSISTOR
Q3403	2SD1328	TRANSISTOR
Q3404	2SD1328	TRANSISTOR
Q3405	2SD601A	TRANSISTOR
Q3406	2SD601A	TRANSISTOR
Q6751	2SC2925S	TRANSISTOR
Q7101	2SD601A	TRANSISTOR
Q7102	2SD601A	TRANSISTOR
Q7103	2SB709A	TRANSISTOR
Q7104	2SB709A	TRANSISTOR
Q7105	2SB709A	TRANSISTOR
Q7106	2SD601A	TRANSISTOR
Q7107	2SD601A	TRANSISTOR
Q7401	2SD601A	TRANSISTOR
Q7402	2SD601A	TRANSISTOR

Ref. No	Part No.	Description	Ref. No	Part No.	Description
Q7410	XN6501	TRANSISTOR	D254	MA700	DIODE
Q7411	XN6501	TRANSISTOR	D255	MA165	DIODE
Q7412	XN6501	TRANSISTOR	D256	MA165	DIODE
Q7417	2SB709A	TRANSISTOR	D352	MA165	DIODE
Q7502	2SK2847	FET	D355	MA188	DIODE
Q7540	2SC3311A	TRANSISTOR	D356	MA188	DIODE
Q7541	2SC3311A	TRANSISTOR	D357	MA188	DIODE
Q7542	2SC3311A	TRANSISTOR	D358	MA188	DIODE
Q7543	2SA1309A	TRANSISTOR	D363	MA165	DIODE
Q7544	2SC1473	TRANSISTOR	D366	AM01Z	DIODE
Q7545	2SA1309A	TRANSISTOR	D367	MA188	DIODE
Q7701	2SB709A	TRANSISTOR	D368	MA188	DIODE
Q7702	2SB709A	TRANSISTOR	D369	MA188	DIODE
Q7703	2SB709A	TRANSISTOR	D370	MA188	DIODE
Q7704	2SB709A	TRANSISTOR	D382	MA165	DIODE
Q7705	2SB709A	TRANSISTOR	D387	MA188	DIODE
Q7706	2SB709A	TRANSISTOR	D388	MA188	DIODE
Q7707	2SD601A	TRANSISTOR	D389	MA188	DIODE
Q7708	2SD601A	TRANSISTOR	D390	MA188	DIODE
Q7709	2SD601A	TRANSISTOR	D400	MA165	DIODE
Q7710	2SB709A	TRANSISTOR	D401	MA4051M	ZENER DIODE
Q7711	2SB709A	TRANSISTOR	D402	MA165	DIODE
Q7712	2SB709A	TRANSISTOR	D403	ERA15-02	DIODE
Q7714	2SB709A	TRANSISTOR	D404	ERA15-02	DIODE
Q7715	2SC3311A	TRANSISTOR	D406	MA4062M	ZENER DIODE
Q7717	2SC3311A	TRANSISTOR	D408	MA4062M	ZENER DIODE
Q7718	2SC3311A	TRANSISTOR	D409	MA4062M	ZENER DIODE
Q7719	2SD601A	TRANSISTOR	D411	MTZJ27D	ZENER DIODE
Q7720	2SD601A	TRANSISTOR	D412	MA700A	DIODE
Q7721	2SD601A	TRANSISTOR	D413	AM01Z	DIODE
Q7722	2SD601A	TRANSISTOR	D414	AM01Z	DIODE
Q7723	2SD601A	TRANSISTOR	D446	MA4110M	ZENER DIODE
Q7724	2SD601A	TRANSISTOR	D458	MA4062M	ZENER DIODE
Q7725	2SD601A	TRANSISTOR	D459	MA4062M	ZENER DIODE
Q7726	2SD601A	TRANSISTOR	D500	MA165	DIODE
Q7727	2SD601A	TRANSISTOR	D501	MA4062M	ZENER DIODE
Q7728	2SD601A	TRANSISTOR	D502	MA700A	DIODE
Q7729	2SD601A	TRANSISTOR	D503	ERA15-02	DIODE
Q7730	2SD601A	TRANSISTOR	D504	MA165	DIODE
Q7735	2SB709A	TRANSISTOR	D505	MA165	DIODE
Q7736	2SD601A	TRANSISTOR	D506	MA165	DIODE
Q7737	2SD601A	TRANSISTOR	D508	MA700A	DIODE
Q7738	2SD601A	TRANSISTOR	D509	MA178	DIODE
Q7741	2SD601A	TRANSISTOR	D511	MTZJ5.1B	ZENER DIODE
Q7742	2SD601A	TRANSISTOR	D513	MTZJ24A	ZENER DIODE
Q7743	2SD601A	TRANSISTOR	D514	MA165	DIODE
Q7744	2SD601A	TRANSISTOR	D527	MTZJ24A	ZENER DIODE
Q7745	2SD601A	TRANSISTOR	D540	MTZJ6.8C	ZENER DIODE
Q7746	2SD601A	TRANSISTOR	D541	MA165	DIODE
Q7747	2SD601A	TRANSISTOR	D543	D1NL40V70	DIODE
Q7748	2SD601A	TRANSISTOR	D551	MTZJ15C	ZENER DIODE
Q9601	2SB709A	TRANSISTOR	D552	D1NL40V70	DIODE
Q9602	2SD601A	TRANSISTOR	D553	D1NL40V70	DIODE
Q9603	2SD601A	TRANSISTOR	D554	D1NL40V70	DIODE
Q9604	2SB709A	TRANSISTOR	D555	MA178	DIODE
Q9605	2SB709A	TRANSISTOR	D556	MTZJ27D	ZENER DIODE
Q9606	2SB709A	TRANSISTOR	D557	MTZJ5.1A	ZENER DIODE
Q9607	2SB709A	TRANSISTOR	D559	MA178	DIODE
Q9608	2SB709A	TRANSISTOR	D560	MA29WA	DIODE
Q9609	2SD601A	TRANSISTOR	D565	MTZJ27D	ZENER DIODE
Q9611	2SB709A	TRANSISTOR	D571	AU01Z	DIODE
Q9612	2SB709A	TRANSISTOR	D572	RH3F	DIODE
Q9613	2SD601A	TRANSISTOR	D585	D1NL40V70	DIODE
Q9614	2SD601A	TRANSISTOR	D591	ERA15-02	DIODE
			D592	ERA15-02	DIODE
	DIODES		D700	MA165	DIODE
D001	MA4020	ZENER DIODE	D702	MA29B	DIODE
D002	MA4020	ZENER DIODE	D704	RP1H	DIODE
D003	MA4330M	ZENER DIODE	D750	FMRG5HS	DIODE
D252	MA165	DIODE	D801	D4SB80Z	DIODE
D253	MA700	DIODE			

Ref. No	Part No.	Description
D803	ERA15-04	DIODE
D805	MA4180M	ZENER DIODE
D806	MA4051M	ZENER DIODE
D809	MA700A	DIODE
D811	MA29WB	DIODE
D812	MA4120M	ZENER DIODE
D815	TVSA81004	DIODE
D816	MA4051M	ZENER DIODE
D817	ERA22-02	DIODE
D818	MA2240B	ZENER DIODE
D819	TMPG10G3	DIODE
D820	EG01C	DIODE
D821	AU01Z	DIODE
D823	MA4220M	ZENER DIODE
D840	FML14S	DIODE
D841	EU02	DIODE
D843	EG01C	DIODE
D844	MA651	DIODE
D845	S2L20U	DIODE
D846	TVSRU3N	DIODE
D847	RU3YX-M	DIODE
D848	FMLG16S	DIODE
D849	FML22S	DIODE
D850	MA4051H	ZENER DIODE
D853	MA165	DIODE
D855	MA165	DIODE
D856	MA165	DIODE
D857	D1NL40V70	DIODE
D858	MA4051M	ZENER DIODE
D859	MA165	DIODE
D860	MA165	DIODE
D861	MA165	DIODE
D862	MA165	DIODE
D863	MA165	DIODE
D864	MA4051M	ZENER DIODE
D865	MA4051M	ZENER DIODE
D868	MA165	DIODE
D869	MA165	DIODE
D870	MA165	DIODE
D872	MA165	DIODE
D873	MA165	DIODE
D874	MA4068M	ZENER DIODE
D953	TVSSR2KN	DIODE
D962	MA188	DIODE
D973	TVSSR2KN	DIODE
D974	MA188	DIODE
D983	TVSSR2KN	DIODE
D984	MA188	DIODE
D1011	MA165	DIODE
D1050	LN11WP38	LED
D1051	LN21RCPHL	LED (RED)
D1102	MA4051M	ZENER DIODE
D1103	MA4051M	ZENER DIODE
D1104	MA165	DIODE
D1105	MA165	DIODE
D1107	MA165	DIODE
D1109	MA165	DIODE
D1110	MA165	DIODE
D1111	MA165	DIODE
D1112	MA165	DIODE
D1113	MA165	DIODE
D1114	MA165	DIODE
D1115	MA4051M	ZENER DIODE
D1116	MA165	DIODE
D1117	MA165	DIODE
D1118	MA152K	DIODE
D1119	MA152K	DIODE
D1501	MA151A	DIODE
D1801	MA151A	DIODE
D1802	MA151A	DIODE

Ref. No	Part No.	Description
D2101	MA4120	ZENER DIODE
D2102	MA4120	ZENER DIODE
D2351	MTZJ5.6B	ZENER DIODE
D2401	MA165	DIODE
D2403	MTZJ12C	ZENER DIODE
D2404	MTZJ12C	ZENER DIODE
D2405	MTZJ12C	ZENER DIODE
D2406	MTZJ12C	ZENER DIODE
D2407	MTZJ12C	ZENER DIODE
D2408	MTZJ12C	ZENER DIODE
D2551	D5L60F4015	DIODE
D2552	TVSEH1	DIODE
D2553	MA4075H	ZENER DIODE
D2554	EU02	DIODE
D2555	EU02	DIODE
D2556	EG01C	DIODE
D2558	EU02	DIODE
D2559	RU4AM	DIODE
D2561	MA4200M	ZENER DIODE
D2611	MA165	DIODE
D2616	MA165	DIODE
D2619	MA165	DIODE
D2630	MA167	DIODE
D2631	MA167	DIODE
D2640	MA167	DIODE
D2641	MA167	DIODE
D2650	MA167	DIODE
D2651	MA167	DIODE
D2660	MA167	DIODE
D2661	MA167	DIODE
D2680	MTZJ6.2A	ZENER DIODE
D3006	MA4100	ZENER DIODE
D3008	MA723	DIODE
D3009	MA723	DIODE
D3011	MA858	DIODE
D3351	MA165	DIODE
D3352	MA165	DIODE
D3361	MA165	DIODE
D3362	MA165	DIODE
D3371	MA165	DIODE
D3372	MA165	DIODE
D3401	MTZJ12C	ZENER DIODE
D3402	MTZJ12C	ZENER DIODE
D3805	TVSA81004	DIODE
D6701	ERZV10V621P2	VARISTOR
D6702	ERZV10V621P2	VARISTOR
D6703	ERC13-08	DIODE
D6705	EG01C	DIODE
D6710	MA2082-A	ZENER DIODE
D6712	ERC13-08	DIODE
D6714	ERZV10D102C1	VARISTOR
D6751	ERA22-02	DIODE
D6752	ERA22-02	DIODE
D6753	MA4180M	ZENER DIODE
D6754	MA4120M	ZENER DIODE
D6756	EU02	DIODE
D6758	MA165	DIODE
D6759	MA4051L	ZENER DIODE
D7001	MA4056M	ZENER DIODE
D7002	MA4056M	ZENER DIODE
D7413	MA152WK	DIODE
D7419	MA152K	DIODE
D7503	MA4270M	ZENER DIODE
D7504	MA700A	DIODE
D7505	MA4120M	ZENER DIODE
D7506	MA29WB	DIODE
D7509	AU01Z	DIODE
D7513	TVSA81004	DIODE
D7514	MA4051M	ZENER DIODE
D7515	ERA22-02	DIODE

Ref. No	Part No.	Description	Ref. No	Part No.	Description
D7516	MA2240B	ZENER DIODE	L401	TLTACC470J	PEAKING COIL
D7517	TMPG10G3	DIODE	L402	EXCELSA39	BEAD CHOKE
D7518	ERA15-04	DIODE	L550	EXCELSA35	BEAD CHOKE
D7519	D4SB80Z	DIODE	L552	EXCELSA24	BEAD CHOKE
D7521	TVSA81004	DIODE	L553	ELH5L718	HORIZONTAL COIL
D7543	MA165	DIODE	L554	EXCELSA24	BEAD CHOKE
D7544	MA165	DIODE	L556	ELEIE682KA	CHOKE COIL
D7545	MA165	DIODE	L558	EXCELSA24	BEAD CHOKE
D7546	MA165	DIODE	L561	EXCELSA35	BEAD CHOKE
D7547	MA165	DIODE	L570	TALL08N330KA	INDUCTION COIL
D7548	MA165	DIODE	L571	TALL08N330KA	INDUCTION COIL
D7549	MA4180M	ZENER DIODE	L572	TALL08N220KA	INDUCTION COIL
D7550	MA4100M	ZENER DIODE	L600	TSKA064	BEAD CHOKE
D7552	MA4039M	ZENER DIODE	L801	ELF24V025A	LINE FILTER
D7553	MA165	DIODE	L802	EXCELSA35	BEAD CHOKE
D7554	MA165	DIODE	L803	EXCELSA35	BEAD CHOKE
D7555	MA165	DIODE	L805	EXCELSA35	BEAD CHOKE
D7556	MA165	DIODE	L806	EXCELSA35	BEAD CHOKE
D7557	MA4036M	ZENER DIODE	L807	EXCELSA35	BEAD CHOKE
D7558	MA165	DIODE	L808	EXCELSA35	BEAD CHOKE
D7559	MA4036M	ZENER DIODE	L809	EXCELDR25C	BEAD CHOKE
D7560	MA165	DIODE	L810	EXCELSA35	BEAD CHOKE
D7562	EU02	DIODE	L812	EXCELDR25C	BEAD CHOKE
D7563	FML-G12S	DIODE	L813	EXCELSA35	BEAD CHOKE
D7564	FML-G12S	DIODE	L840	EXCELSA35	BEAD CHOKE
D7565	EU02	DIODE	L841	EXCELSA35	BEAD CHOKE
D7701	MA3091M	ZENER DIODE	L842	EXCELSA35	BEAD CHOKE
D7706	MA3051M	ZENER DIODE	L843	EXCELSA35	BEAD CHOKE
D7711	MA152K	DIODE	L844	EXCELSA35	BEAD CHOKE
D7712	MA152K	DIODE	L847	EXCELSA35	BEAD CHOKE
D7714	MA152K	DIODE	L848	EXCELSA35	BEAD CHOKE
D7715	MA152WK	DIODE	L849	EXCELSA35	BEAD CHOKE
D7716	MA152K	DIODE	L850	EXCELSA35	BEAD CHOKE
D7717	MA152WK	DIODE	L851	EXCELSA35	BEAD CHOKE
D7719	MA152K	DIODE	L853	EXCELSA35	BEAD CHOKE
D7721	MA152K	DIODE	L856	EXCELSA35	BEAD CHOKE
D7722	MA152K	DIODE	L857	EXCELSA35	BEAD CHOKE
D9601	MA29T-B	DIODE	L858	EXCELSA35	BEAD CHOKE
D9605	MA4062M	ZENER DIODE	L859	EXCELSA35	BEAD CHOKE
D9607	MA165	DIODE	L861	TALL08N220KA	INDUCTION COIL
D9610	MA4043M	ZENER DIODE	L862	TALL08N330KA	INDUCTION COIL
D9611	MA165	DIODE	L863	TALL08N101KA	INDUCTION COIL
D9612	MA165	DIODE	L864	TALL08N220KA	INDUCTION COIL
D9615	MA165	DIODE	L865	EXCELSA35	BEAD CHOKE
D9616	MA178	DIODE	L866	TALL08N101KA	INDUCTION COIL
D9617	MTZJ9.1C	ZENER DIODE	L904	TLUABTA560K	PEAKING COIL
D9618	MTZJ9.1C	ZENER DIODE	L951	EXCELSA35	BEAD CHOKE
D9620	MA165	DIODE	L953	EXCELSA35	BEAD CHOKE
			L954	EXCELSA35	BEAD CHOKE
			L956	EXCELSA35	BEAD CHOKE
	COILS		L973	EXCELSA35	BEAD CHOKE
L002	EXCELDR35C	BEAD CHOKE	L974	EXCELSA35	BEAD CHOKE
L003	EXCELDR35C	BEAD CHOKE	L975	EXCELSA35	BEAD CHOKE
L004	EXCELSA35	BEAD CHOKE	L983	EXCELSA35	BEAD CHOKE
L005	TLTACC100K	PEAKING COIL	L984	EXCELSA35	BEAD CHOKE
L008	ELJFC2R2KB	INDUCTION COIL	L985	EXCELSA35	BEAD CHOKE
L009	ELJFC2R2KB	INDUCTION COIL	L1011	EXCELSA35	BEAD CHOKE
L251	EXCELSA35	BEAD CHOKE	L1101	EXCELDR35C	BEAD CHOKE
L252	EXCELSA35	BEAD CHOKE	L1103	TLTACC4R7K	PEAKING COIL
L253	EXCELSA35	BEAD CHOKE	L1104	EXCELDR35C	BEAD CHOKE
L254	EXCELSA35	BEAD CHOKE	L1105	EXCELDR35C	BEAD CHOKE
L351	ELEBD101KA	PEAKING COIL	L1106	TLTACC4R7K	PEAKING COIL
L352	TLTACC6R8J	PEAKING COIL	L1107	EXCELSA35	BEAD CHOKE
L353	EXCELDR25C	BEAD CHOKE	L1507	TLTACC1R8K	PEAKING COIL
L361	ELEBD101KA	PEAKING COIL	L1508	TLTACC3R3K	PEAKING COIL
L362	TLTACC6R8J	PEAKING COIL	L1509	EXCELDR35C	BEAD CHOKE
L363	EXCELDR25C	BEAD CHOKE	L1510	EXCELDR35C	BEAD CHOKE
L381	ELEBD101KA	PEAKING COIL	L1511	TLTACC1R8K	PEAKING COIL
L382	TLTACC6R8J	PEAKING COIL	L1516	EXCELDR35C	BEAD CHOKE
L383	EXCELDR25C	BEAD CHOKE	L1519	EXCEMT103DC	EMI FILTER
L400	TLTACC470J	PEAKING COIL			

Ref. No	Part No.	Description
L1523	EXCEMT103DC	EMI FILTER
L1525	EXCEMT103DC	EMI FILTER
L1527	EXCEMT103DC	EMI FILTER
L1528	EXCELD35C	BEAD CHOKE
L1529	EXCELD35C	BEAD CHOKE
L1532	EXCELD35C	BEAD CHOKE
L1533	EXCELD35C	BEAD CHOKE
L1534	EXCELD35C	BEAD CHOKE
L1535	EXCELD35C	BEAD CHOKE
L1536	EXCELD35C	BEAD CHOKE
L1537	TLTACC100K	PEAKING COIL
L1538	TLTACC1R8K	PEAKING COIL
L1539	TLTACC3R3K	PEAKING COIL
L1540	TLTACC1R8K	PEAKING COIL
L1541	TLTACC3R3K	PEAKING COIL
L1542	TLTACC1R8K	PEAKING COIL
L1543	TLTACC3R3K	PEAKING COIL
L1802	EXCELD35C	BEAD CHOKE
L1803	EXCELD35C	BEAD CHOKE
L1807	EXCELD35C	BEAD CHOKE
L1808	TLTACC470K	PEAKING COIL
L1809	EXCELD35C	BEAD CHOKE
L1811	EXCELD35C	BEAD CHOKE
L2101	TLTACC100K	PEAKING COIL
L2102	TLTACC3R9K	PEAKING COIL
L2103	TLTACC100K	PEAKING COIL
L2104	EXCELD35C	BEAD CHOKE
L2106	TLTACC6R8K	PEAKING COIL
L2381	EXCELSA35	BEAD CHOKE
L2382	EXCELSA35	BEAD CHOKE
L2401	EXCELSA35	BEAD CHOKE
L2402	EXCELSA35	BEAD CHOKE
L2403	EXCELSA35	BEAD CHOKE
L2404	EXCELSA35	BEAD CHOKE
L2407	EXCELSA35	BEAD CHOKE
L2408	EXCELSA35	BEAD CHOKE
L2409	EXCELSA35	BEAD CHOKE
L2410	EXCELSA35	BEAD CHOKE
L2411	EXCELSA35	BEAD CHOKE
L2412	EXCELSA35	BEAD CHOKE
L2413	EXCELSA35	BEAD CHOKE
L2414	EXCELSA35	BEAD CHOKE
L2415	EXCELSA35	BEAD CHOKE
L2416	EXCELSA35	BEAD CHOKE
L2502	EXCELD35C	BEAD CHOKE
L2503	EXCELD35C	BEAD CHOKE
L2504	EXCELD35C	BEAD CHOKE
L2505	EXCEMT103DC	EMI FILTER
L2506	EXCEMT103DC	EMI FILTER
L2551	EXCELSA35	BEAD CHOKE
L2552	EXCELSA35	BEAD CHOKE
L2553	EXCELSA35	BEAD CHOKE
L2555	EXCELSA35	BEAD CHOKE
L2556	EXCELSA35	BEAD CHOKE
L2560	EXCELSA35	BEAD CHOKE
L2561	EXCELSA35	BEAD CHOKE
L2630	TALL08N330KA	INDUCTION COIL
L2631	TALL08N330KA	INDUCTION COIL
L2640	TALL08N330KA	INDUCTION COIL
L2641	TALL08N330KA	INDUCTION COIL
L3001	TLTACC100K	PEAKING COIL
L3002	TALL08N330KA	INDUCTION COIL
L3205	EXCELD35C	BEAD CHOKE
L3281	EXCELSA35	BEAD CHOKE
L3282	EXCELSA35	BEAD CHOKE
L3401	TLTACC1R5K	PEAKING COIL
L3402	TLTACC1R5K	PEAKING COIL
L3403	TLTACC1R5K	PEAKING COIL
L3404	TLTACC1R5K	PEAKING COIL
L3405	TLTACC1R5K	PEAKING COIL

Ref. No	Part No.	Description
L3406	TLTACC1R5K	PEAKING COIL
L3407	TLTACC1R5K	PEAKING COIL
L3408	TLTACC1R5K	PEAKING COIL
L3409	TLTACC100K	PEAKING COIL
L3410	TLTACC1R5K	PEAKING COIL
L3411	TLTACC1R5K	PEAKING COIL
L3412	TLTACC1R5K	PEAKING COIL
L3413	TLTACC1R5K	PEAKING COIL
△ L6701	TLPF108	CHOKE COIL
△ L6703	TLPF108	CHOKE COIL
△ L6704	ELF24V019A	LINE FILTER
△ L6710	ELF24V020A	LINE FILTER
△ L6716	ELF24V020A	LINE FILTER
L6718	EXCELD25C	BEAD CHOKE
L6719	EXCELD25C	BEAD CHOKE
L6720	EXCELD25C	BEAD CHOKE
L6721	EXCELD25C	BEAD CHOKE
L6751	EXCELSA35	BEAD CHOKE
L6753	EXCELSA35	BEAD CHOKE
L6755	TALL08N101KA	INDUCTION COIL
L6756	TALL08N101KA	INDUCTION COIL
L7001	EXCELSA39	BEAD CHOKE
L7002	EXCELSA39	BEAD CHOKE
L7003	EXCELSA39	BEAD CHOKE
L7004	EXCELSA39	BEAD CHOKE
L7005	EXCELSA39	BEAD CHOKE
L7006	EXCELSA39	BEAD CHOKE
L7106	TLTACC180J	PEAKING COIL
L7501	EXCELSA35	BEAD CHOKE
L7502	EXCELD25C	BEAD CHOKE
L7504	EXCELSA35	BEAD CHOKE
L7505	EXCELSA35	BEAD CHOKE
L7506	EXCELSA35	BEAD CHOKE
L7508	EXCELSA35	BEAD CHOKE
L7509	EXCELSA35	BEAD CHOKE
△ L7510	ELF20N010A	LINE FILTER
L7511	EXCELD25C	BEAD CHOKE
L7512	EXCELD25C	BEAD CHOKE
L7513	EXCELSA35	BEAD CHOKE
L7540	TLTACC220J	PEAKING COIL
L7541	TLTACC220J	PEAKING COIL
L7542	EXCELSA35	BEAD CHOKE
L7543	EXCELSA35	BEAD CHOKE
L7544	EXCELSA35	BEAD CHOKE
L7545	EXCELSA35	BEAD CHOKE
L7546	EXCELSA35	BEAD CHOKE
L7547	EXCELSA35	BEAD CHOKE
L7548	EXCELSA35	BEAD CHOKE
L7549	EXCELSA35	BEAD CHOKE
L7702	TLTACC100J	PEAKING COIL
L7703	TLTACC100J	PEAKING COIL
L7704	TLTACC100J	PEAKING COIL
L9602	EXCELD35C	BEAD CHOKE
L9603	EXCELD35C	BEAD CHOKE
L9604	ELEXH2R7KA	PEAKING COIL
L9605	ELEXH2R7KA	PEAKING COIL
L9606	ELEXH2R7KA	PEAKING COIL
L9607	ELEXH2R7KA	PEAKING COIL
L9611	ELB4D018B	DELAY LINE
L9612	ELB4D018B	DELAY LINE
L9613	ELB4D018B	DELAY LINE
L9614	EXCELSA39	BEAD CHOKE
LC7002	EXCEMT101BC	EMI FILTER
LC7003	EXCEMT101BC	EMI FILTER
LC7006	EXCEMT101BC	EMI FILTER
LC7007	EXCEMT101BC	EMI FILTER
LC7008	EXCEMT101BC	EMI FILTER
LC7009	EXCEMT101BC	EMI FILTER
LC7010	EXCEMT101BC	EMI FILTER
LC7011	EXCEMT101BC	EMI FILTER

Ref. No	Part No.	Description	Ref. No	Part No.	Description
LC7101	TAX10094	EMI FILTER	R385	ER0S2CKF1502	M 15KOHM F 1/4W
LC7102	TAX10094	EMI FILTER	R386	ER0S2CKF6980	M 698 OHM F 1/4W
LC7103	EXCEMT222DC	EMI FILTER	R388	ERDS2TJ272	C 2.7KOHM J 1/4W
LC7104	EXCEMT222DC	EMI FILTER	R390	ERG3FJX473D	M 47KOHM J 3W
LC7105	EXCEMT222DC	EMI FILTER	R394	ERDS2TJ103	C 10KOHM J 1/4W
LC7106	EXCEMT222DC	EMI FILTER	R395	ERDS2TC0	C 0 OHM 1/4W
LC7401	EXCEMT101BC	EMI FILTER	R396	ERC12GK331	S 330 OHM 1/2W
LC7402	EXCEMT471BC	EMI FILTER	R401	ERDS2TJ272	C 2.7KOHM J 1/4W
	TRANSFORMERS		R404	ERDS2TJ473	C 47KOHM J 1/4W
T501	ETS29AC1N9AC	SWITCHING TRANS	R407	ERDS2TJ560	C 56 OHM J 1/4W
T552	ETS28AE299AC	SWITCHING TRANS	R408	ERDS2TJ560	C 56 OHM J 1/4W
T553	ETH19Y61AY	H DRIVE TRANS	R409	ERDS2TJ331	C 330 OHM J 1/4W
△ T554	KFT7AQ002F1	FLYBACK TRANS	R410	ERDS2TJ222	C 2.2KOHM J 1/4W
T556	TLHJ005	CHOKE COIL	R412	ERDS2TJ473	C 47KOHM J 1/4W
△ T802	ETS49AH226AC	SWITCHING TRANS	R413	ERDS2TJ473	C 47KOHM J 1/4W
△ T2552	ETS35AA457AD	SWITCHING TRANS	R414	ERDS2TJ221	C 220 OHM J 1/4W
△ T6701	ETS19AB186AG	SWITCHING TRANS	R415	ER0S2CKF1002	M 10KOHM F 1/4W
T7501	ETS29AK3D6AC	SWITCHING TRANS	R416	ERDS2TJ682	C 6.8KOHM J 1/4W
	RESISTORS		R417	ER0S2CKF1961	M 1.96KOHM F 1/4W
R001	ERJ6GEY0R00	M 0 OHM J 1/10W	R418	ERDS2TJ682	C 6.8KOHM J 1/4W
R002	ERJ6GEYJ223	M 22KOHM J 1/10W	R419	ERG3FJS331D	M 330 OHM J 3W
R003	ERJ6GEYJ393	M 39KOHM J 1/10W	R420	ERDS2TJ563	C 56KOHM J 1/4W
R101	ERJ6GEYJ561	M 560 OHM J 1/10W	R421	ERDS2TJ224	C 220KOHM J 1/4W
R102	ERJ6GEYJ101	M 100 OHM J 1/10W	R422	ER0S2CKF1962	M 19.6KOHM F 1/4W
R103	ERJ6GEYJ563	M 56KOHM J 1/10W	R423	ER0S2CKF8451	M 8.45KOHM F 1/4W
R104	ERJ6GEYJ471	M 470 OHM J 1/10W	R426	ER0S2CKF5102	M 510KOHM F 1/4W
R105	ERJ6GEYJ332	M 3.3KOHM J 1/10W	R427	ER0S2CKF1202	M 12KOHM F 1/4W
R106	ERJ6GEYJ821	M 820 OHM J 1/10W	R431	ER0S2CKF9760	M 976 OHM F 1/4W
R107	ERJ6GEYJ102	M 1KOHM J 1/10W	R432	ER0S2CKF7501	M 7.5KOHM F 1/4W
R109	ERJ6GEYJ103	M 10KOHM J 1/10W	R434	ER0S2CKF6801	M 6.8KOHM F 1/4W
R110	ERJ6GEYJ222	M 2.2KOHM J 1/10W	R436	ER0S2CKF6041	M 6.04KOHM F 1/4W
R111	ERJ6GEYJ331	M 330 OHM J 1/10W	R437	ERDS2TC0	C 0 OHM 1/4W
R251	ERJ6GEYJ681	M 680 OHM J 1/10W	R441	ER0S2CKF1652	M 16.5KOHM F 1/4W
R253	ERJ6GEYJ104	M 100KOHM J 1/10W	R442	ER0S2CKF1202	M 12KOHM F 1/4W
R254	ERJ6GEYJ681	M 680 OHM J 1/10W	R443	ERDS2TJ101	C 100 OHM J 1/4W
R255	ERJ6GEYJ104	M 100KOHM J 1/10W	R444	ERDS2TJ103	C 10KOHM J 1/4W
R256	ERJ6GEYJ222	M 2.2KOHM J 1/10W	R446	ERDS2TJ472	C 4.7KOHM J 1/4W
R257	ERJ6GEY0R00	M 0 OHM J 1/10W	R448	ERDS2TJ272	C 2.7KOHM J 1/4W
R259	ERJ6GEY0R00	M 0 OHM J 1/10W	R449	ERDS2TJ222	C 2.2KOHM J 1/4W
R260	ERJ6GEYJ103	M 10KOHM J 1/10W	R451	ERX12SJ1R8	M 1.8 OHM J 1/2W
R261	ERJ6GEYJ222	M 2.2KOHM J 1/10W	R452	ERX12SJ1R8	M 1.8 OHM J 1/2W
R262	ERJ6GEYJ103	M 10KOHM J 1/10W	R453	ERDS2TJ104	C 100KOHM J 1/4W
R263	ERJ6GEYJ104	M 100KOHM J 1/10W	R454	ERDS2TC0	C 0 OHM 1/4W
R264	ERJ6GEYJ473	M 47KOHM J 1/10W	R456	ERDS2TJ123	C 12KOHM J 1/4W
R265	ERDS1TJ2R2	C 2.2 OHM J 1/2W	R457	ER0S2CKF1652	M 16.5KOHM F 1/4W
R266	ERDS1TJ2R2	C 2.2 OHM J 1/2W	R462	ERDS2TJ152	C 1.5KOHM J 1/4W
R269	ERJ6GEYJ273	M 27KOHM J 1/10W	R464	ERDS2TJ560	C 56 OHM J 1/4W
R270	ERJ6GEYJ273	M 27KOHM J 1/10W	R466	ERDS2TJ560	C 56 OHM J 1/4W
R271	ERJ6GEYJ272	M 2.7KOHM J 1/10W	R471	ERDS1FJ1R0	C 1 OHM J 1/2W
R272	ERJ6GEYJ103	M 10KOHM J 1/10W	R476	ERDS2TJ103	C 10KOHM J 1/4W
R273	ERJ6GEYJ331	M 330 OHM J 1/10W	R478	ERDS2TJ562	C 5.6KOHM J 1/4W
R352	ER0S2CKF2802	M 28KOHM F 1/4W	R491	ERDS2TJ273	C 27KOHM J 1/4W
R353	ER0S2CKF1502	M 15KOHM F 1/4W	R492	ERDS2TJ683	C 68KOHM J 1/4W
R354	ER0S2CKF6980	M 698 OHM F 1/4W	R493	ERDS2TJ302	C 3KOHM J 1/4W
R355	ERDS2TC0	C 0 OHM 1/4W	R494	ERDS2TJ682	C 6.8KOHM J 1/4W
R356	ERDS2TJ272	C 2.7KOHM J 1/4W	R495	ER0S2CKF6801	M 6.8KOHM F 1/4W
R358	ERG3FJX473D	M 47KOHM J 3W	R502	ERDS2TJ473	C 47KOHM J 1/4W
R360	ERDS2TJ103	C 10KOHM J 1/4W	R506	ERDS2TJ102	C 1KOHM J 1/4W
R361	ERC12GK331	S 330 OHM 1/2W	R507	ERDS2TJ101	C 100 OHM J 1/4W
R368	ER0S2CKF2802	M 28KOHM F 1/4W	R508	ERDS2TJ472	C 4.7KOHM J 1/4W
R369	ER0S2CKF1502	M 15KOHM F 1/4W	R510	ERDS2TJ105	C 1MOHM J 1/4W
R372	ER0S2CKF6980	M 698 OHM F 1/4W	R512	ERDS2TJ103	C 10KOHM J 1/4W
R374	ERDS2TJ272	C 2.7KOHM J 1/4W	R513	ERQ14AJ2R2P	F 2.2 OHM J 1/4W
R375	ERDS2TC0	C 0 OHM 1/4W	R514	ERDS2TJ682	C 6.8KOHM J 1/4W
R376	ERG3FJX473D	M 47KOHM J 3W	R515	ERDS2TJ103	C 10KOHM J 1/4W
R377	ERDS2TJ101	C 100 OHM J 1/4W	R516	ERG1FJS102D	M 1KOHM J 1W
R378	ERDS2TJ103	C 10KOHM J 1/4W	R517	ERF3AJ101	W 100 OHM J 3W
R379	ERC12GK331	S 330 OHM 1/2W	R518	ERDS2TJ331	C 330 OHM J 1/4W
R384	ER0S2CKF2802	M 28KOHM F 1/4W	R519	ERDS2TJ223	C 22KOHM J 1/4W
			R521	ERDS2TJ103	C 10KOHM J 1/4W

Ref. No	Part No.	Description			
R522	ERDS2TJ153	C	15KOHM	J	1/4W
R523	ERDS2TJ103	C	10KOHM	J	1/4W
R527	ER0S2CKF5361	M	5.36KOHM	F	1/4W
R532	ERDS2TJ682	C	6.8KOHM	J	1/4W
R533	ERDS2TJ222	C	2.2KOHM	J	1/4W
R534	ERDS2TJ473	C	47KOHM	J	1/4W
R535	ERDS2TJ104	C	100KOHM	J	1/4W
R536	ERDS2TJ471	C	470 OHM	J	1/4W
R538	ERDS2TJ271	C	270 OHM	J	1/4W
R545	ERDS2TJ822	C	8.2KOHM	J	1/4W
R548	ERDS2TJ101	C	100 OHM	J	1/4W
R550	ERDS2TJ221	C	220 OHM	J	1/4W
R551	ERX2FJS5R6D	M	5.6 OHM	J	2W
R552	ERDS2TJ821	C	820 OHM	J	1/4W
R557	ER0S2CKF4702	M	47KOHM	F	1/4W
R558	ER0S2CKF3902	M	39KOHM	F	1/4W
R559	ERDS2TJ101	C	100 OHM	J	1/4W
R560	ERDS2TJ561	C	560 OHM	J	1/4W
R562	ERD25FJ470	C	47 OHM	J	1/4W
R563	ERDS2TJ473	C	47KOHM	J	1/4W
R565	ERG1FJS331D	M	330 OHM	J	1W
R566	ERG3FJS101D	M	100 OHM	J	3W
R567	ERDS2TJ472	C	4.7KOHM	J	1/4W
R568	ERDS2TJ103	C	10KOHM	J	1/4W
R570	ERDS2TJ153	C	15KOHM	J	1/4W
R572	ERQ1ABJP331S	F	330 OHM	J	1W
R573	ERQ2CJP100S	F	10 OHM	J	2W
R574	ERG5SJ123H	M	12KOHM	J	5W
R576	ERDS2TJ472	C	4.7KOHM	J	1/4W
R578	ERDS2TJ100	C	10 OHM	J	1/4W
R579	ERF5ZK6R8	W	6.8 OHM	Z	5W
R580	ERX2FJSR22D	M	0.22 OHM	J	2W
R581	EVMEASA00B53	CONTROL			5KOHMB
R582	ERDS2TJ222	C	2.2KOHM	J	1/4W
R586	ERC12GK103	S	10KOHM	K	1/2W
R587	ERG3SJ102H	M	1KOHM	J	3W
R589	ER0S2CKF1003	M	100KOHM	F	1/4W
R590	ERDS1FJ103	C	10KOHM	J	1/2W
R591	ERDS1FJ122	C	1.2KOHM	J	1/2W
R593	ERDS1FJ102	C	1KOHM	J	1/2W
R595	ER0S2CKF1502	M	15KOHM	F	1/4W
R596	ERG2FJS822D	M	8.2KOHM	J	2W
R597	ERDS2TJ102	C	1KOHM	J	1/4W
R598	EVMEASA00B14	CONTROL			10KOHMB
R599	ER0S2CKF5601	M	5.6KOHM	F	1/4W
R605	ERDS2TJ432	C	4.3KOHM	J	1/4W
R606	ERDS2TJ473	C	47KOHM	J	1/4W
R607	ERDS2TJ104	C	100KOHM	J	1/4W
R610	ERDS2TJ682	C	6.8KOHM	J	1/4W
R611	ERDS2TJ222	C	2.2KOHM	J	1/4W
R612	ERDS2TJ222	C	2.2KOHM	J	1/4W
R613	ERDS2TJ101	C	100 OHM	J	1/4W
R614	ERDS2TJ102	C	1KOHM	J	1/4W
R615	ER0S2CKF1002	M	10KOHM	F	1/4W
R616	ER0S2CKF7151	M	7.15KOHM	F	1/4W
R617	ERDS2TJ102	C	1KOHM	J	1/4W
R618	ERDS2TJ102	C	1KOHM	J	1/4W
R619	ERDS2TJ101	C	100 OHM	J	1/4W
R620	ERDS2TJ104	C	100KOHM	J	1/4W
R621	ERDS2TJ123	C	12KOHM	J	1/4W
R622	ERDS2TJ222	C	2.2KOHM	J	1/4W
R625	ERDS2TJ681	C	680 OHM	J	1/4W
R626	ERDS2TJ101	C	100 OHM	J	1/4W
R627	ER0S2CKF1202	M	12KOHM	F	1/4W
R628	ER0S2CKF7501	M	7.5KOHM	F	1/4W
R667	ERDS2TJ101	C	100 OHM	J	1/4W
R668	ERDS2TJ222	C	2.2KOHM	J	1/4W
R669	ERDS2TJ103	C	10KOHM	J	1/4W
R670	ERDS2TJ182	C	1.8KOHM	J	1/4W
R671	ERDS2TJ101	C	100 OHM	J	1/4W

Ref. No	Part No.	Description			
R701	ERDS2TJ102	C	1KOHM	J	1/4W
R702	ERDS2TJ103	C	10KOHM	J	1/4W
R703	ERDS2TJ473	C	47KOHM	J	1/4W
R707	ERDS2TJ473	C	47KOHM	J	1/4W
R708	ERDS2TJ101	C	100 OHM	J	1/4W
R709	ER0S2CKF8661	M	8.66KOHM	F	1/4W
R710	ER0S2CKF3742	M	37.4KOHM	F	1/4W
R711	ER0S2CKF1691	M	1.69KOHM	F	1/4W
R712	ER0S2CKF1000	M	100 OHM	F	1/4W
R713	ER0S2CKF3321	M	3.32KOHM	F	1/4W
R714	ERDS2TJ101	C	100 OHM	J	1/4W
R715	ERDS2TJ221	C	220 OHM	J	1/4W
R716	ERDS2TJ104	C	100KOHM	J	1/4W
R717	ERDS2TJ121	C	120 OHM	J	1/4W
R718	ER0S2CKF8200	M	820 OHM	F	1/4W
R719	ERDS2TJ273	C	27KOHM	J	1/4W
R720	ERDS2TJ823	C	82KOHM	J	1/4W
R721	ERDS2TJ153	C	15KOHM	J	1/4W
R722	ERDS2TJ472	C	4.7KOHM	J	1/4W
R723	ERDS2TJ101	C	100 OHM	J	1/4W
R724	ERDS2TJ102	C	1KOHM	J	1/4W
R725	ERDS2TC0	C	0 OHM		1/4W
R726	EVMESGA00B13	CONTROL			1KOHMB
R727	ERDS2TJ331	C	330 OHM	J	1/4W
R730	ERDS2TJ153	C	15KOHM	J	1/4W
R731	ERDS2TJ472	C	4.7KOHM	J	1/4W
R732	ERDS2TJ473	C	47KOHM	J	1/4W
R733	ERDS2TJ223	C	22KOHM	J	1/4W
R734	ERDS2TJ102	C	1KOHM	J	1/4W
R735	ERDS2TJ562	C	5.6KOHM	J	1/4W
R736	ERDS2TJ122	C	1.2KOHM	J	1/4W
R737	ERDS2TJ101	C	100 OHM	J	1/4W
R738	ERDS2TJ271	C	270 OHM	J	1/4W
R739	ERDS2TJ152	C	1.5KOHM	J	1/4W
R740	ERDS2TJ391	C	390 OHM	J	1/4W
R741	EVMESGA00B24	CONTROL			20KOHMB
R742	ERDS2TJ274	C	270KOHM	J	1/4W
R743	ERDS2TJ273	C	27KOHM	J	1/4W
R744	ERDS2TJ823	C	82KOHM	J	1/4W
R745	ERDS2TJ153	C	15KOHM	J	1/4W
R746	ERDS2TJ472	C	4.7KOHM	J	1/4W
R747	ERDS2TJ101	C	100 OHM	J	1/4W
R748	ERDS2TJ102	C	1KOHM	J	1/4W
R749	ERDS2TJ222	C	2.2KOHM	J	1/4W
R750	ERDS2TJ102	C	1KOHM	J	1/4W
R751	ERG2SJ273H	M	27KOHM	J	2W
R752	ERG2SJ273H	M	27KOHM	J	2W
R753	ERG2SJ273H	M	27KOHM	J	2W
R754	ERG2SJ273H	M	27KOHM	J	2W
R755	ERG2SJ273H	M	27KOHM	J	2W
R756	ERG2SJ273H	M	27KOHM	J	2W
R757	ERC12GK333	S	33KOHM	K	1/2W
R758	ERDS2TJ562	C	5.6KOHM	J	1/4W
R759	ERDS2TJ823	C	82KOHM	J	1/4W
R760	ERDS2TJ821	C	820 OHM	J	1/4W
R764	ERDS2TJ153	C	15KOHM	J	1/4W
R765	ERDS2TJ562	C	5.6KOHM	J	1/4W
R766	ERDS2TJ152	C	1.5KOHM	J	1/4W
R767	ERDS2TJ101	C	100 OHM	J	1/4W
R768	ERDS2TJ271	C	270 OHM	J	1/4W
R770	ERDS2TJ152	C	1.5KOHM	J	1/4W
R772	ERDS2TJ103	C	10KOHM	J	1/4W
R773	ERDS2TJ823	C	82KOHM	J	1/4W
R774	ERDS2TJ104	C	100KOHM	J	1/4W
R783	ERDS2TJ331	C	330 OHM	J	1/4W
R784	ERDS2TJ271	C	270 OHM	J	1/4W
R790	ERDS2TJ682	C	6.8KOHM	J	1/4W
R794	ERF2AJ391	W	390 OHM	J	2W
R802	ERG3FJS153D	M	15KOHM	J	3W
R803	ERDS2TJ561	C	560 OHM	J	1/4W

Ref. No	Part No.	Description	Ref. No	Part No.	Description
R804	ERG3FJS153D	M 15KOHM J 3W	R903	ERDS2TJ153	C 15KOHM J 1/4W
R806	ERDS2TJ393	C 39KOHM J 1/4W	R904	ERDS2TJ472	C 4.7KOHM J 1/4W
R809	ERG2SJ333H	M 33KOHM J 2W	R905	ERDS2TJ472	C 4.7KOHM J 1/4W
R810	ERG2SJ333H	M 33KOHM J 2W	R906	ERDS2TJ101	C 100 OHM J 1/4W
R811	ERDS2TJ332	C 3.3KOHM J 1/4W	R907	ERDS2TJ151	C 150 OHM J 1/4W
R812	ERDS2TJ223	C 22KOHM J 1/4W	R908	ERDS2TJ272	C 2.7KOHM J 1/4W
R814	ERDS2TJ101	C 100 OHM J 1/4W	R914	ERDS2TJ562	C 5.6KOHM J 1/4W
R815	ERDS2TJ122	C 1.2KOHM J 1/4W	R915	ERDS2TJ182	C 1.8KOHM J 1/4W
R816	ERDS2TJ223	C 22KOHM J 1/4W	R916	ERDS2TJ391	C 390 OHM J 1/4W
R818	ERDS2TJ471	C 470 OHM J 1/4W	R917	ERDS2TJ470	C 47 OHM J 1/4W
R820	ERDS1FJ331	C 330 OHM J 1/2W	R920	ERDS2TJ181	C 180 OHM J 1/4W
R821	ERDS2TJ181	C 180 OHM J 1/4W	R922	ERDS2TJ103	C 10KOHM J 1/4W
R822	ERDS1FJ390	C 39 OHM J 1/2W	R923	ERDS2TJ103	C 10KOHM J 1/4W
R823	ERDS1FJ5R6	C 5.6 OHM J 1/2W	R932	ERDS2TJ103	C 10KOHM J 1/4W
R824	ERDS1FJ390	C 39 OHM J 1/2W	R933	ERDS2TJ103	C 10KOHM J 1/4W
R826	ERX12SJR22P	M 0.22 OHM J 1/2W	R942	ERDS2TJ103	C 10KOHM J 1/4W
R827	ERX12SJR22P	M 0.22 OHM J 1/2W	R943	ERDS2TJ103	C 10KOHM J 1/4W
R828	ERX12SJR22P	M 0.22 OHM J 1/2W	R951	ERDS2TJ271	C 270 OHM J 1/4W
R829	ERG5SJ823H	M 82KOHM J 5W	R952	ERDS1FJ152	C 1.5KOHM J 1/2W
△ R830	ERD75TAJ825	C 8.2MOHM J 3/4W	R953	ERDS2TJ271	C 270 OHM J 1/4W
R832	ERDS2TJ102	C 1KOHM J 1/4W	R954	ERDS1FJ152	C 1.5KOHM J 1/2W
R840	ERDS1TJ4R7	C 4.7 OHM J 1/2W	R955	ERDS2TJ271	C 270 OHM J 1/4W
R841	ERDS1TJ682	C 6.8KOHM J 1/2W	R956	ERDS1FJ152	C 1.5KOHM J 1/2W
R842	ERDS2TJ101	C 100 OHM J 1/4W	R960	ERQ14AJ100P	F 10 OHM J 1/4W
R843	ERDS2TJ102	C 1KOHM J 1/4W	R964	ERDS2FJ122	C 1.2KOHM 1/4W
R844	ERG3FJS101D	M 100 OHM J 3W	R965	ERDS2TJ683	C 68KOHM J 1/4W
R845	ERG3FJS101D	M 100 OHM J 3W	R966	ERG1SJ271P	M 270 OHM J 1W
R848	ERD25FJ391	C 390 OHM J 1/4W	R967	ERDS2TJ683	C 68KOHM J 1/4W
R852	ERDS2TJ183	C 18KOHM J 1/4W	R968	ERDS2TJ122	C 1.2KOHM J 1/4W
R853	ERDS2TJ273	C 27KOHM J 1/4W	R969	ERDS1FJ390	C 39 OHM J 1/2W
R854	ERDS2TJ103	C 10KOHM J 1/4W	R970	ERDS2TJ8R2	C 8.2 OHM J 1/4W
R855	ERDS2TJ563	C 56KOHM J 1/4W	R971	ERDS2TJ8R2	C 8.2 OHM J 1/4W
R856	ERDS2TJ103	C 10KOHM J 1/4W	R972	ERDS1FJ390	C 39 OHM J 1/2W
R857	ERDS2TJ683	C 68KOHM J 1/4W	R973	ERDS1FJ470	C 47 OHM J 1/2W
R858	ERDS2TJ823	C 82KOHM J 1/4W	R974	ERDS2FJ122	C 1.2KOHM 1/4W
R859	ERDS1TJ333	C 33KOHM J 1/2W	R975	ERDS2TJ683	C 68KOHM J 1/4W
R860	ERDS1TJ223	C 22KOHM J 1/2W	R977	ERDS2TJ683	C 68KOHM J 1/4W
R861	ERDS2TJ563	C 56KOHM J 1/4W	R978	ERDS2TJ122	C 1.2KOHM J 1/4W
R862	ERDS1TJ223	C 22KOHM J 1/2W	R979	ERDS1FJ390	C 39 OHM J 1/2W
R863	ERDS2TJ103	C 10KOHM J 1/4W	R980	ERDS2TJ8R2	C 8.2 OHM J 1/4W
R864	ERDS2TJ471	C 470 OHM J 1/4W	R981	ERDS2TJ8R2	C 8.2 OHM J 1/4W
R865	ERG1SJ183P	M 18KOHM J 1W	R982	ERDS1FJ390	C 39 OHM J 1/2W
R866	ERG1SJ183P	M 18KOHM J 1W	R983	ERG1SJ271P	M 270 OHM J 1W
R867	ER0S2CKF1742	M 17.4KOHM F 1/4W	R984	ERDS2FJ122	C 1.2KOHM 1/4W
R868	ER0S2CKF1742	M 17.4KOHM F 1/4W	R985	ERDS2TJ683	C 68KOHM J 1/4W
R869	ER0S2CKF1472	M 14.7KOHM F 1/4W	R986	ERDS2TJ683	C 68KOHM J 1/4W
R870	ER0S2CKF1472	M 14.7KOHM F 1/4W	R987	ERDS2TJ122	C 1.2KOHM J 1/4W
R871	ERX1FJS1R0D	M 1.0 OHM J 1W	R988	ERG1SJ271P	M 270 OHM J 1W
R872	ERX1FJS1R0D	M 1.0 OHM J 1W	R991	ERDS1FJ390	C 39 OHM J 1/2W
R873	ERDS1FJ102	C 1KOHM J 1/2W	R992	ERDS1FJ390	C 39 OHM J 1/2W
R874	ERDS1TJ104	C 100KOHM J 1/2W	R993	ERDS2TJ6R8	C 6.8 OHM J 1/4W
R875	ERDS1TJ104	C 100KOHM J 1/2W	R994	ERDS2TJ6R8	C 6.8 OHM J 1/4W
R876	ERDS2TJ682	C 6.8KOHM J 1/4W	R1011	ERDS2TJ102	C 1KOHM J 1/4W
R877	ERDS2TJ102	C 1KOHM J 1/4W	R1013	ERDS2TJ102	C 1KOHM J 1/4W
R878	ERDS2TJ103	C 10KOHM J 1/4W	R1015	ERDS2TJ103	C 10KOHM J 1/4W
R879	ERDS2TJ101	C 100 OHM J 1/4W	R1019	ERDS2TJ473	C 47KOHM J 1/4W
R880	ERDS1TJ393	C 39KOHM J 1/2W	R1021	ERDS2TJ472	C 4.7KOHM J 1/4W
R881	ERDS2TJ562	C 5.6KOHM J 1/4W	R1022	ERDS2TJ332	C 3.3KOHM J 1/4W
R882	ERDS2TJ822	C 8.2KOHM J 1/4W	R1023	ERJ6GEYJ103	M 10KOHM J 1/10W
R883	ERDS2TJ822	C 8.2KOHM J 1/4W	R1024	ERJ6GEYJ103	M 10KOHM J 1/10W
R887	ER0S2CKF1742	M 17.4KOHM F 1/4W	R1025	ERJ6GEYJ103	M 10KOHM J 1/10W
R888	ER0S2CKF1472	M 14.7KOHM F 1/4W	R1026	ERJ6GEYJ101	M 100 OHM J 1/10W
R889	ERQ2CJP1R0S	F 1 OHM J 2W	R1027	ERJ6GEYJ101	M 100 OHM J 1/10W
R890	ER0S2CKF3900	M 390 OHM F 1/4W	R1028	ERJ6GEYJ101	M 100 OHM J 1/10W
R891	ER0S2CKF1821	M 1.82KOHM F 1/4W	R1029	ERJ6GEYJ101	M 100 OHM J 1/10W
R892	ERDS2TJ473	C 47KOHM J 1/4W	R1030	ERJ6GEYJ101	M 100 OHM J 1/10W
R893	ERDS2TJ102	C 1KOHM J 1/4W	R1031	ERJ6GEYJ101	M 100 OHM J 1/10W
R894	ERDS2TJ272	C 2.7KOHM J 1/4W	R1032	ERJ6GEYJ822	M 8.2KOHM J 1/10W
R901	ERDS1FJ821	C 820 OHM J 1/2W	R1033	ERJ6GEYJ103	M 10KOHM J 1/10W
R902	ERDS2TJ683	C 68KOHM J 1/4W	R1034	ERJ6GEYJ333	M 33KOHM J 1/10W

Ref. No	Part No.	Description
R1035	ERJ6GEYJ103	M 10KOHM J 1/10W
R1036	ERJ6GEYJ221	M 220 OHM J 1/10W
R1037	ERJ6GEYJ103	M 10KOHM J 1/10W
R1050	ERDS2TJ101	C 100 OHM J 1/4W
R1071	ERDS2TJ103	C 10KOHM J 1/4W
R1072	ERDS2TJ222	C 2.2KOHM J 1/4W
R1073	ERDS2TJ222	C 2.2KOHM J 1/4W
R1074	ERDS2TJ332	C 3.3KOHM J 1/4W
R1075	ERDS2TJ512	C 5.1KOHM J 1/4W
R1076	ERDS2TJ912	C 9.1KOHM J 1/4W
R1077	ERJ6GEYJ101	M 100 OHM J 1/10W
R1078	ERJ6GEYJ473	M 47KOHM J 1/10W
R1079	ERJ6GEYJ473	M 47KOHM J 1/10W
R1101	ERJ6GEYJ100	M 10 OHM J 1/10W
R1102	ERJ6GEYJ182	M 1.8KOHM J 1/10W
R1103	ERJ6GEYJ472	M 4.7KOHM J 1/10W
R1104	ERJ6GEYJ101	M 100 OHM J 1/10W
R1105	ERJ6GEYJ101	M 100 OHM J 1/10W
R1106	ERJ6GEYJ101	M 100 OHM J 1/10W
R1107	ERJ6GEYJ101	M 100 OHM J 1/10W
R1108	ERJ6GEYJ472	M 4.7KOHM J 1/10W
R1109	ERJ6GEYJ101	M 100 OHM J 1/10W
R1110	ERJ6GEYJ101	M 100 OHM J 1/10W
R1111	ERJ6GEYJ101	M 100 OHM J 1/10W
R1112	ERJ6GEYJ101	M 100 OHM J 1/10W
R1113	ERJ6GEYJ472	M 4.7KOHM J 1/10W
R1114	ERJ6GEYJ101	M 100 OHM J 1/10W
R1116	ERJ6GEYJ101	M 100 OHM J 1/10W
R1117	ERJ6GEYJ332	M 3.3KOHM J 1/10W
R1118	ERJ6GEYJ332	M 3.3KOHM J 1/10W
R1119	ERJ6GEYJ332	M 3.3KOHM J 1/10W
R1120	ERJ6GEYJ332	M 3.3KOHM J 1/10W
R1121	ERJ6GEYJ822	M 8.2KOHM J 1/10W
R1122	ERJ6GEYJ472	M 4.7KOHM J 1/10W
R1123	ERJ6GEYJ823	M 82KOHM J 1/10W
R1124	ERJ6GEYJ101	M 100 OHM J 1/10W
R1125	ERJ6GEYJ101	M 100 OHM J 1/10W
R1126	ERJ6GEYJ101	M 100 OHM J 1/10W
R1127	ERJ6GEYJ101	M 100 OHM J 1/10W
R1128	ERJ6GEYJ472	M 4.7KOHM J 1/10W
R1129	ERJ6GEYJ472	M 4.7KOHM J 1/10W
R1130	ERJ6GEYJ104	M 100KOHM J 1/10W
R1131	ERJ6GEYJ101	M 100 OHM J 1/10W
R1132	ERJ6GEYJ101	M 100 OHM J 1/10W
R1133	ERJ6GEYJ101	M 100 OHM J 1/10W
R1134	ERJ6GEYJ101	M 100 OHM J 1/10W
R1135	ERJ6GEYJ225	M 2.2MOHM J 1/10W
R1138	ERJ6GEYJ273	M 27KOHM J 1/10W
R1139	ERJ6GEYJ472	M 4.7KOHM J 1/10W
R1140	ERJ6GEYJ392	M 3.9KOHM J 1/10W
R1141	ERJ6GEYJ103	M 10KOHM J 1/10W
R1142	ERJ6GEYJ103	M 10KOHM J 1/10W
R1143	ERJ6GEYJ101	M 100 OHM J 1/10W
R1144	ERJ6GEYJ473	M 47KOHM J 1/10W
R1145	ERJ6GEYJ332	M 3.3KOHM J 1/10W
R1146	ERJ6GEYJ101	M 100 OHM J 1/10W
R1147	ERJ6GEYJ223	M 22KOHM J 1/10W
R1148	ERJ6GEYJ104	M 100KOHM J 1/10W
R1149	ERJ6GEYJ104	M 100KOHM J 1/10W
R1150	ERJ6GEYJ104	M 100KOHM J 1/10W
R1151	ERJ6GEYJ103	M 10KOHM J 1/10W
R1152	ERJ6GEYJ224	M 220KOHM J 1/10W
R1153	ERJ6GEYJ273	M 27KOHM J 1/10W
R1154	ERJ6GEYJ221	M 220 OHM J 1/10W
R1155	ERJ6GEYJ474	M 470KOHM J 1/10W
R1156	ERJ6GEY0R00	M 0 OHM J 1/10W
R1157	ERJ6GEYJ100	M 10 OHM J 1/10W
R1158	ERJ6GEYJ684	M 680KOHM J 1/10W
R1159	ERJ6GEYJ683	M 68KOHM J 1/10W
R1160	ERJ6GEY0R00	M 0 OHM J 1/10W

Ref. No	Part No.	Description
R1161	ERJ6GEYJ184	M 180KOHM J 1/10W
R1162	ERJ6GEYJ683	M 68KOHM J 1/10W
R1163	ERJ6GEYJ563	M 56KOHM J 1/10W
R1164	ERJ6GEYJ823	M 82KOHM J 1/10W
R1165	ERJ6GEYJ104	M 100KOHM J 1/10W
R1166	ERJ6GEYJ683	M 68KOHM J 1/10W
R1167	ERJ6GEYJ563	M 56KOHM J 1/10W
R1168	ERJ6GEYJ334	M 330KOHM J 1/10W
R1169	ERJ6GEYJ683	M 68KOHM J 1/10W
R1170	ERJ6GEYJ472	M 4.7KOHM J 1/10W
R1171	ERJ6GEYJ472	M 4.7KOHM J 1/10W
R1172	ERJ6GEYJ821	M 820 OHM J 1/10W
R1173	ERJ6GEYJ681	M 680 OHM J 1/10W
R1174	ERJ6GEYJ681	M 680 OHM J 1/10W
R1175	ERJ6GEYJ101	M 100 OHM J 1/10W
R1176	ERJ6GEYJ101	M 100 OHM J 1/10W
R1177	ERJ6GEYJ103	M 10KOHM J 1/10W
R1178	ERJ6GEYJ103	M 10KOHM J 1/10W
R1179	ERJ6GEYJ562	M 5.6KOHM J 1/10W
R1180	ERJ6GEYJ472	M 4.7KOHM J 1/10W
R1181	ERJ6GEYJ101	M 100 OHM J 1/10W
R1182	ERJ6GEYJ472	M 4.7KOHM J 1/10W
R1183	ERJ6GEYJ563	M 56KOHM J 1/10W
R1184	ERJ6GEYJ101	M 100 OHM J 1/10W
R1185	ERJ6GEYJ182	M 1.8KOHM J 1/10W
R1186	ERJ6GEYJ103	M 10KOHM J 1/10W
R1187	ERJ6GEYJ103	M 10KOHM J 1/10W
R1188	ERJ6GEYJ472	M 4.7KOHM J 1/10W
R1189	ERJ6GEYJ101	M 100 OHM J 1/10W
R1190	ERJ6GEYJ472	M 4.7KOHM J 1/10W
R1194	ERJ6GEYJ681	M 680 OHM J 1/10W
R1195	ERJ6GEYJ103	M 10KOHM J 1/10W
R1198	ERJ6GEYJ103	M 10KOHM J 1/10W
R1200	ERJ6GEYJ472	M 4.7KOHM J 1/10W
R1201	ERJ6GEYJ471	M 470 OHM J 1/10W
R1202	ERJ6GEYJ152	M 1.5KOHM J 1/10W
R1203	ERJ6GEYJ101	M 100 OHM J 1/10W
R1204	ERJ6GEYJ332	M 3.3KOHM J 1/10W
R1206	ERJ6GEYJ101	M 100 OHM J 1/10W
R1207	ERJ6GEYJ103	M 10KOHM J 1/10W
R1208	ERJ6GEYJ102	M 1KOHM J 1/10W
R1233	ERJ6GEYJ510	M 51 OHM J 1/10W
R1234	ERJ6GEYJ472	M 4.7KOHM J 1/10W
R1501	ERJ6GEY0R00	M 0 OHM J 1/10W
R1502	ERJ6GEYJ151	M 150 OHM J 1/10W
R1503	ERJ6GEYJ222	M 2.2KOHM J 1/10W
R1504	ERJ6GEYJ151	M 150 OHM J 1/10W
R1505	ERJ6GEYJ471	M 470 OHM J 1/10W
R1506	ERJ6GEYJ271	M 270 OHM J 1/10W
R1507	ERJ6GEYJ102	M 1KOHM J 1/10W
R1508	ERJ6GEYJ471	M 470 OHM J 1/10W
R1509	ERJ6GEYJ471	M 470 OHM J 1/10W
R1510	ERJ6GEYJ8R2	M 8.2 OHM J 1/10W
R1511	ERJ6GEYJ101	M 100 OHM J 1/10W
R1513	ERJ6GEYJ101	M 100 OHM J 1/10W
R1514	ERJ6GEYJ180	M 18 OHM J 1/10W
R1515	ERJ6GEYJ101	M 100 OHM J 1/10W
R1517	ERJ6GEYJ180	M 18 OHM J 1/10W
R1518	ERJ6GEYJ180	M 18 OHM J 1/10W
R1519	ERJ6GEYJ561	M 560 OHM J 1/10W
R1520	ERJ6GEYJ471	M 470 OHM J 1/10W
R1521	ERJ6GEYJ820	M 82 OHM J 1/10W
R1522	ERJ6GEYJ103	M 10KOHM J 1/10W
R1523	ERJ6GEYJ390	M 39 OHM J 1/10W
R1524	ERJ6GEYJ560	M 56 OHM J 1/10W
R1525	ERJ6GEYJ271	M 270 OHM J 1/10W
R1526	ERJ6GEY0R00	M 0 OHM J 1/10W
R1527	ERJ6GEYJ100	M 10 OHM J 1/10W
R1528	ERJ6GEYJ151	M 150 OHM J 1/10W
R1530	ERJ6GEYJ560	M 56 OHM J 1/10W

Ref. No	Part No.	Description	Ref. No	Part No.	Description
R1531	ERJ6GEYJ151	M 150 OHM J 1/10W	R1610	ERJ6GEYJ101	M 100 OHM J 1/10W
R1532	ERJ6GEYJ151	M 150 OHM J 1/10W	R1611	ERJ6GEYJ101	M 100 OHM J 1/10W
R1533	ERJ6GEYJ181	M 180 OHM J 1/10W	R1613	ERJ6GEYJ102	M 1KOHM J 1/10W
R1534	ERJ6GEYJ272	M 2.7KOHM J 1/10W	R1614	ERJ6GEYOR00	M 0 OHM J 1/10W
R1535	ERJ6GEYJ103	M 10KOHM J 1/10W	R1615	ERJ6GEYOR00	M 0 OHM J 1/10W
R1536	ERJ6GEYJ470	M 47 OHM J 1/10W	R1616	ERJ6GEYJ101	M 100 OHM J 1/10W
R1537	ERJ6GEYJ103	M 10KOHM J 1/10W	R1617	ERJ6ENF1100	M 110 OHM 1/10W
R1538	ERJ6GEYJ181	M 180 OHM J 1/10W	R1618	ERJ6GEYJ103	M 10KOHM J 1/10W
R1540	ERJ6GEYJ102	M 1KOHM J 1/10W	R1619	ERJ6GEYJ103	M 10KOHM J 1/10W
R1541	ERJ6GEYJ102	M 1KOHM J 1/10W	R1620	ERJ6GEYJ331	M 330 OHM J 1/10W
R1542	ERJ6GEYJ151	M 150 OHM J 1/10W	R1621	ERJ6GEYJ471	M 470 OHM J 1/10W
R1543	ERJ6GEYJ103	M 10KOHM J 1/10W	R1622	ERJ6GEYJ102	M 1KOHM J 1/10W
R1544	ERJ6GEYJ561	M 560 OHM J 1/10W	R1623	ERJ6GEYJ471	M 470 OHM J 1/10W
R1545	ERJ6ENF3600	M 360 OHM 1/10W	R1624	ERJ6GEYJ333	M 33KOHM J 1/10W
R1546	ERJ6GEYJ561	M 560 OHM J 1/10W	R1625	ERJ6GEYJ221	M 220 OHM J 1/10W
R1547	ERJ6GEYJ103	M 10KOHM J 1/10W	R1626	ERJ6GEYJ332	M 3.3KOHM J 1/10W
R1548	ERJ6GEYJ221	M 220 OHM J 1/10W	R1627	ERJ6GEYJ100	M 10 OHM J 1/10W
R1550	ERJ6GEYJ103	M 10KOHM J 1/10W	R1628	ERJ6GEYOR00	M 0 OHM J 1/10W
R1551	ERJ6GEYJ271	M 270 OHM J 1/10W	R1629	ERJ6GEYJ101	M 100 OHM J 1/10W
R1552	ERJ6GEYJ103	M 10KOHM J 1/10W	R1630	ERJ6GEYJ103	M 10KOHM J 1/10W
R1553	ERJ6GEYJ750	M 75 OHM J 1/10W	R1631	ERJ6ENF1500	M 150 OHM 1/10W
R1554	ERJ6GEYJ101	M 100 OHM J 1/10W	R1632	ERJ6GEYOR00	M 0 OHM J 1/10W
R1555	ERJ6GEYJ101	M 100 OHM J 1/10W	R1633	ERJ6GEYOR00	M 0 OHM J 1/10W
R1556	ERJ6GEYJ101	M 100 OHM J 1/10W	R1634	ERJ6GEYJ101	M 100 OHM J 1/10W
R1559	ERJ6ENF2200	M 220 OHM 1/10W	R1635	ERJ6GEYJ271	M 270 OHM J 1/10W
R1560	ERJ6GEYJ560	M 56 OHM J 1/10W	R1636	ERJ6GEYJ101	M 100 OHM J 1/10W
R1561	ERJ6GEYOR00	M 0 OHM J 1/10W	R1637	ERJ6GEYJ271	M 270 OHM J 1/10W
R1562	ERJ6ENF4750	M 475 OHM 1/10W	R1639	ERJ6GEYJ331	M 330 OHM J 1/10W
R1563	ERJ6GEYJ271	M 270 OHM J 1/10W	R1640	ERJ6GEYOR00	M 0 OHM J 1/10W
R1564	ERJ6ENF2200	M 220 OHM 1/10W	R1641	ERJ6GEYJ473	M 47KOHM J 1/10W
R1565	ERJ6GEYJ820	M 82 OHM J 1/10W	R1642	ERJ6GEYJ183	M 18KOHM J 1/10W
R1566	ERJ6GEYJ331	M 330 OHM J 1/10W	R1643	ERJ6GEYJ473	M 47KOHM J 1/10W
R1567	ERJ6ENF1500	M 150 OHM 1/10W	R1644	ERJ6GEYJ183	M 18KOHM J 1/10W
R1568	ERJ6ENF1500	M 150 OHM 1/10W	R1645	ERJ6GEYJ473	M 47KOHM J 1/10W
R1569	ERJ6ENF1500	M 150 OHM 1/10W	R1646	ERJ6GEYJ183	M 18KOHM J 1/10W
R1570	ERJ6ENF2701	M 2.7KOHM 1/10W	R1660	ERJ6GEYJ103	M 10KOHM J 1/10W
R1571	ERJ6GEYJ103	M 10KOHM J 1/10W	R1661	ERJ6GEYJ471	M 470 OHM J 1/10W
R1572	ERJ6GEYJ103	M 10KOHM J 1/10W	R1662	ERJ6GEYJ223	M 22KOHM J 1/10W
R1573	ERJ6ENF1500	M 150 OHM 1/10W	R1663	ERJ6GEYJ331	M 330 OHM J 1/10W
R1574	ERJ6GEYJ560	M 56 OHM J 1/10W	R1664	ERJ6GEYJ103	M 10KOHM J 1/10W
R1575	ERJ6GEYJ102	M 1KOHM J 1/10W	R1665	ERJ6GEYJ471	M 470 OHM J 1/10W
R1576	ERJ6GEYJ102	M 1KOHM J 1/10W	R1666	ERJ6GEYJ223	M 22KOHM J 1/10W
R1577	ERJ6GEYJ102	M 1KOHM J 1/10W	R1667	ERJ6GEYJ331	M 330 OHM J 1/10W
R1578	ERJ6GEYJ301	M 300 OHM J 1/10W	R1668	ERJ6GEYJ103	M 10KOHM J 1/10W
R1579	ERJ6GEYJ431	M 430 OHM J 1/10W	R1669	ERJ6GEYJ471	M 470 OHM J 1/10W
R1580	ERJ6GEYJ511	M 510 OHM J 1/10W	R1670	ERJ6GEYJ223	M 22KOHM J 1/10W
R1581	ERJ6GEYJ151	M 150 OHM J 1/10W	R1671	ERJ6GEYJ331	M 330 OHM J 1/10W
R1582	ERJ6GEYJ103	M 10KOHM J 1/10W	R1672	ERJ6GEYJ471	M 470 OHM J 1/10W
R1583	ERJ6GEYJ561	M 560 OHM J 1/10W	R1673	ERJ6GEYOR00	M 0 OHM J 1/10W
R1584	ERJ6GEYJ561	M 560 OHM J 1/10W	R1674	ERJ6GEYOR00	M 0 OHM J 1/10W
R1585	ERJ6GEYJ103	M 10KOHM J 1/10W	R1675	ERJ6GEYOR00	M 0 OHM J 1/10W
R1586	ERJ6GEYOR00	M 0 OHM J 1/10W	R1676	ERJ6GEYJ560	M 56 OHM J 1/10W
R1587	ERJ6GEYOR00	M 0 OHM J 1/10W	R1677	ERJ6ENF6800	M 680 OHM 1/10W
R1588	ERJ6GEYJ221	M 220 OHM J 1/10W	R1678	ERJ6ENF1500	M 150 OHM 1/10W
R1589	ERJ6GEYJ152	M 1.5KOHM J 1/10W	R1679	ERJ6ENF2000	M 200 OHM 1/10W
R1590	ERJ6GEYJ101	M 100 OHM J 1/10W	R1680	ERJ6GEYJ271	M 270 OHM J 1/10W
R1591	ERJ6GEYJ103	M 10KOHM J 1/10W	R1681	ERJ6GEYJ271	M 270 OHM J 1/10W
R1592	ERJ6GEYJ101	M 100 OHM J 1/10W	R1682	ERJ6GEYJ271	M 270 OHM J 1/10W
R1593	ERJ6GEYJ101	M 100 OHM J 1/10W	R1683	ERJ6GEYJ271	M 270 OHM J 1/10W
R1594	ERJ6GEYJ101	M 100 OHM J 1/10W	R1684	ERJ6GEYJ271	M 270 OHM J 1/10W
R1595	ERJ6GEYJ101	M 100 OHM J 1/10W	R1685	ERQ14AJ100P	F 10 OHM J 1/4W
R1598	ERJ6GEYJ101	M 100 OHM J 1/10W	R1686	ERJ6GEYJ103	M 10KOHM J 1/10W
R1599	ERJ6GEYJ101	M 100 OHM J 1/10W	R1687	ERJ6GEYJ103	M 10KOHM J 1/10W
R1600	ERJ6GEYJ103	M 10KOHM J 1/10W	R1688	ERJ6GEYJ331	M 330 OHM J 1/10W
R1603	ERJ6GEYJ101	M 100 OHM J 1/10W	R1690	ERJ6GEYJ750	M 75 OHM J 1/10W
R1604	ERJ6GEYJ820	M 82 OHM J 1/10W	R1691	ERJ6GEYJ750	M 75 OHM J 1/10W
R1605	ERJ6GEYJ183	M 18KOHM J 1/10W	R1692	ERJ6GEYJ750	M 75 OHM J 1/10W
R1606	ERJ6GEYJ273	M 27KOHM J 1/10W	R1801	ERJ6GEYJ101	M 100 OHM J 1/10W
R1607	ERJ6GEYJ101	M 100 OHM J 1/10W	R1802	ERJ6GEYJ471	M 470 OHM J 1/10W
R1609	ERJ6GEYJ103	M 10KOHM J 1/10W	R1803	ERJ6GEYJ101	M 100 OHM J 1/10W

Ref. No	Part No.	Description
R1804	ERJ6GEYJ431	M 430 OHM J 1/10W
R1805	ERJ6GEYJ682	M 6.8KOHM J 1/10W
R1806	ERJ6GEYJ101	M 100 OHM J 1/10W
R1807	ERJ6GEYJ471	M 470 OHM J 1/10W
R1808	ERJ6GEYJ101	M 100 OHM J 1/10W
R1810	ERJ6GEYJ102	M 1KOHM J 1/10W
R1811	ERJ6GEYJ102	M 1KOHM J 1/10W
R1813	ERJ6GEY0R00	M 0 OHM J 1/10W
R1814	ERJ6GEYJ471	M 470 OHM J 1/10W
R1815	ERJ6GEYJ101	M 100 OHM J 1/10W
R1816	ERJ6GEYJ101	M 100 OHM J 1/10W
R1817	ERJ6GEYJ391	M 390 OHM J 1/10W
R1818	ERJ6GEY0R00	M 0 OHM J 1/10W
R1819	ERJ6GEY0R00	M 0 OHM J 1/10W
R1820	ERJ6GEYJ471	M 470 OHM J 1/10W
R1821	ERJ6GEYJ471	M 470 OHM J 1/10W
R1823	ERJ6GEYJ103	M 10KOHM J 1/10W
R1824	ERJ6GEY0R00	M 0 OHM J 1/10W
R1825	ERJ6GEYJ471	M 470 OHM J 1/10W
R1826	ERJ6GEYJ221	M 220 OHM J 1/10W
R1827	ERJ6GEYJ132	M 1.3KOHM J 1/10W
R1828	ERJ6GEYJ391	M 390 OHM J 1/10W
R1829	ERJ6GEYJ101	M 100 OHM J 1/10W
R1830	ERJ6GEYJ101	M 100 OHM J 1/10W
R1834	ERJ6GEYJ101	M 100 OHM J 1/10W
R1835	ERJ6GEYJ823	M 82KOHM J 1/10W
R1839	ERJ6GEYJ225	M 2.2MOHM J 1/10W
R1840	ERJ6GEY0R00	M 0 OHM J 1/10W
R1841	ERJ6GEYJ153	M 15KOHM J 1/10W
R1842	ERJ6GEYJ151	M 150 OHM J 1/10W
R1845	ERJ6GEYJ221	M 220 OHM J 1/10W
R1846	ERJ6GEYJ221	M 220 OHM J 1/10W
R1847	ERJ6GEYJ221	M 220 OHM J 1/10W
R1848	ERJ6GEYJ471	M 470 OHM J 1/10W
R1849	ERJ6GEYJ471	M 470 OHM J 1/10W
R1850	ERJ6GEYJ471	M 470 OHM J 1/10W
R1851	ERJ6GEYJ471	M 470 OHM J 1/10W
R1852	ERJ6GEYJ471	M 470 OHM J 1/10W
R1853	ERJ6GEYJ471	M 470 OHM J 1/10W
R1854	ERJ6GEYJ151	M 150 OHM J 1/10W
R1855	ERJ6GEYJ911	M 910 OHM J 1/10W
R1856	ERJ6GEYJ223	M 22KOHM J 1/10W
R1857	ERC14GJ206	S 20MOHM J 1/4W
R1858	ERC14GJ206	S 20MOHM J 1/4W
R2101	ERJ6GEYJ101	M 100 OHM J 1/10W
R2102	ERJ6GEYJ101	M 100 OHM J 1/10W
R2103	ERJ6GEY0R00	M 0 OHM J 1/10W
R2104	ERJ6GEY0R00	M 0 OHM J 1/10W
R2105	ERJ6GEYJ102	M 1KOHM J 1/10W
R2106	ERJ6GEYJ101	M 100 OHM J 1/10W
R2107	ERJ6GEYJ101	M 100 OHM J 1/10W
R2108	ERJ6GEYJ103	M 10KOHM J 1/10W
R2109	ERJ6GEYJ472	M 4.7KOHM J 1/10W
R2110	ERJ6GEYJ101	M 100 OHM J 1/10W
R2111	ERJ6GEYJ471	M 470 OHM J 1/10W
R2112	ERJ6GEYJ472	M 4.7KOHM J 1/10W
R2114	ERJ6GEYJ101	M 100 OHM J 1/10W
R2117	ERJ6GEYJ222	M 2.2KOHM J 1/10W
R2118	ERJ6GEYJ471	M 470 OHM J 1/10W
R2120	ERJ6GEYJ471	M 470 OHM J 1/10W
R2121	ERJ6GEYJ222	M 2.2KOHM J 1/10W
R2125	ERJ6GEYJ103	M 10KOHM J 1/10W
R2301	ERJ6GEYJ104	M 100KOHM J 1/10W
R2302	ERJ6GEYJ103	M 10KOHM J 1/10W
R2303	ERJ6GEYJ104	M 100KOHM J 1/10W
R2304	ERJ6GEY0R00	M 0 OHM J 1/10W
R2307	ERJ6GEY0R00	M 0 OHM J 1/10W
R2308	ERJ6GEYJ103	M 10KOHM J 1/10W
R2312	ERJ6GEYJ272	M 2.7KOHM J 1/10W
R2314	ERJ6GEY0R00	M 0 OHM J 1/10W

Ref. No	Part No.	Description
R2315	ERJ6GEY0R00	M 0 OHM J 1/10W
R2316	ERJ6GEYJ222	M 2.2KOHM J 1/10W
R2318	ERJ6GEYJ331	M 330 OHM J 1/10W
R2319	ERJ6GEYJ222	M 2.2KOHM J 1/10W
R2320	ERJ6GEYJ101	M 100 OHM J 1/10W
R2321	ERJ6GEYJ101	M 100 OHM J 1/10W
R2351	ERJ6GEYJ102	M 1KOHM J 1/10W
R2352	ERJ6GEYJ102	M 1KOHM J 1/10W
R2353	ERJ6GEYJ103	M 10KOHM J 1/10W
R2354	ERJ6GEYJ103	M 10KOHM J 1/10W
R2355	ERJ6GEYJ103	M 10KOHM J 1/10W
R2356	ERJ6GEYJ103	M 10KOHM J 1/10W
R2357	ERJ6GEYJ562	M 5.6KOHM J 1/10W
R2358	ERJ6GEYJ562	M 5.6KOHM J 1/10W
R2359	ERJ6GEYJ393	M 39KOHM J 1/10W
R2361	ERJ6GEYJ223	M 22KOHM J 1/10W
R2362	ERJ6GEYJ103	M 10KOHM J 1/10W
R2363	ERJ6GEYJ103	M 10KOHM J 1/10W
R2364	ERDS2TJ101	C 100 OHM J 1/4W
R2365	ERJ6GEYJ102	M 1KOHM J 1/10W
R2368	ERJ6GEYJ222	M 2.2KOHM J 1/10W
R2369	ERJ6GEYJ222	M 2.2KOHM J 1/10W
R2370	ERJ6GEYJ103	M 10KOHM J 1/10W
R2371	ERJ6GEYJ103	M 10KOHM J 1/10W
R2374	ERJ6GEYJ103	M 10KOHM J 1/10W
R2375	ERJ6GEYJ103	M 10KOHM J 1/10W
R2376	ERJ6GEYJ103	M 10KOHM J 1/10W
R2377	ERJ6GEYJ333	M 33KOHM J 1/10W
R2401	ERJ6GEYJ222	M 2.2KOHM J 1/10W
R2402	ERJ6GEYJ102	M 1KOHM J 1/10W
R2403	ERJ6GEYJ102	M 1KOHM J 1/10W
R2404	ERJ6GEYJ102	M 1KOHM J 1/10W
R2405	ERJ6GEYJ102	M 1KOHM J 1/10W
R2408	ERJ6GEYJ473	M 47KOHM J 1/10W
R2417	ERJ6GEYJ562	M 5.6KOHM J 1/10W
R2421	ERJ6GEYJ562	M 5.6KOHM J 1/10W
R2422	ERJ6GEYJ273	M 27KOHM J 1/10W
R2423	ERJ6GEYJ184	M 180KOHM J 1/10W
R2424	ERJ6GEYJ184	M 180KOHM J 1/10W
R2425	ERJ6GEYJ273	M 27KOHM J 1/10W
R2426	ERJ6GEYJ104	M 100KOHM J 1/10W
R2427	ERJ6GEYJ104	M 100KOHM J 1/10W
R2428	ERJ6GEYJ104	M 100KOHM J 1/10W
R2429	ERJ6GEYJ273	M 27KOHM J 1/10W
R2430	ERJ6GEYJ273	M 27KOHM J 1/10W
R2431	ERJ6GEYJ104	M 100KOHM J 1/10W
R2432	ERJ6GEYJ184	M 180KOHM J 1/10W
R2433	ERJ6GEYJ184	M 180KOHM J 1/10W
R2441	ERJ6GEYJ821	M 820 OHM J 1/10W
R2442	ERJ6GEYJ332	M 3.3KOHM J 1/10W
R2443	ERJ6GEYJ821	M 820 OHM J 1/10W
R2444	ERJ6GEYJ821	M 820 OHM J 1/10W
R2445	ERJ6GEYJ332	M 3.3KOHM J 1/10W
R2446	ERJ6GEYJ332	M 3.3KOHM J 1/10W
R2447	ERJ6GEYJ821	M 820 OHM J 1/10W
R2448	ERJ6GEYJ332	M 3.3KOHM J 1/10W
R2449	ERJ6GEYJ821	M 820 OHM J 1/10W
R2450	ERJ6GEYJ821	M 820 OHM J 1/10W
R2451	ERJ6GEYJ332	M 3.3KOHM J 1/10W
R2452	ERJ6GEYJ332	M 3.3KOHM J 1/10W
R2453	ERJ6GEYJ473	M 47KOHM J 1/10W
R2454	ERJ6GEYJ473	M 47KOHM J 1/10W
R2455	ERJ6GEYJ473	M 47KOHM J 1/10W
R2456	ERJ6GEYJ473	M 47KOHM J 1/10W
R2457	ERJ6GEYJ473	M 47KOHM J 1/10W
R2458	ERJ6GEYJ473	M 47KOHM J 1/10W
R2461	ERJ6GEYJ184	M 180KOHM J 1/10W
R2462	ERJ6GEYJ203	M 20KOHM J 1/10W
R2463	ERJ6GEYJ104	M 100KOHM J 1/10W
R2464	ERJ6GEYJ184	M 180KOHM J 1/10W

Ref. No	Part No.	Description	Ref. No	Part No.	Description
R2465	ERJ6GEYJ123	M 12KOHM J 1/10W	R2653	ERJ6GEYJ223	M 22KOHM J 1/10W
R2466	ERJ6GEYJ104	M 100KOHM J 1/10W	R2654	ERX12SJ1R0	M 0.1 OHM J 1/2W
R2471	ERJ6GEYJ101	M 100 OHM J 1/10W	R2660	ERJ6GEYJ223	M 22KOHM J 1/10W
R2472	ERJ6GEYJ101	M 100 OHM J 1/10W	R2661	ERJ6GEYOR00	M 0 OHM J 1/10W
R2473	ERJ6GEYJ101	M 100 OHM J 1/10W	R2662	ERJ6GEYJ681	M 680 OHM J 1/10W
R2474	ERJ6GEYJ101	M 100 OHM J 1/10W	R2663	ERJ6GEYJ223	M 22KOHM J 1/10W
R2475	ERJ6GEYJ101	M 100 OHM J 1/10W	R2664	ERX12SJ1R0	M 0.1 OHM J 1/2W
R2476	ERJ6GEYJ101	M 100 OHM J 1/10W	R2682	ERJ6GEYJ102	M 1KOHM J 1/10W
R2501	ERJ6GEYJ101	M 100 OHM J 1/10W	R2683	ERJ6GEYJ562	M 5.6KOHM J 1/10W
R2502	ERJ6GEYJ472	M 4.7KOHM J 1/10W	R3004	ERJ6GEYJ470	M 47 OHM J 1/10W
R2503	ERJ6GEYOR00	M 0 OHM J 1/10W	R3005	ERJ6GEYJ104	M 100KOHM J 1/10W
R2504	ERJ6GEYJ222	M 2.2KOHM J 1/10W	R3006	ERJ6GEYJ221	M 220 OHM J 1/10W
R2508	ERJ6GEYJ471	M 470 OHM J 1/10W	R3007	ERJ6GEYJ750	M 75 OHM J 1/10W
R2509	ERJ6GEYJ471	M 470 OHM J 1/10W	R3008	ERJ6GEYJ470	M 47 OHM J 1/10W
R2511	ERJ6GEYJ101	M 100 OHM J 1/10W	R3009	ERJ6GEYJ470	M 47 OHM J 1/10W
R2512	ERJ6GEYJ222	M 2.2KOHM J 1/10W	R3010	ERJ6GEYJ104	M 100KOHM J 1/10W
R2513	ERJ6GEYJ101	M 100 OHM J 1/10W	R3011	ERJ6GEYJ104	M 100KOHM J 1/10W
R2514	ERJ6GEYJ101	M 100 OHM J 1/10W	R3012	ERJ6GEYJ104	M 100KOHM J 1/10W
R2515	ERJ6GEYJ101	M 100 OHM J 1/10W	R3013	ERJ6GEYJ101	M 100 OHM J 1/10W
R2516	ERJ6GEYJ101	M 100 OHM J 1/10W	R3014	ERJ6GEYJ101	M 100 OHM J 1/10W
R2517	ERJ6GEYJ101	M 100 OHM J 1/10W	R3015	ERJ6GEYJ470	M 47 OHM J 1/10W
R2518	ERJ6GEYJ101	M 100 OHM J 1/10W	R3016	ERJ6GEYJ121	M 120 OHM J 1/10W
R2519	ERJ6GEYJ101	M 100 OHM J 1/10W	R3017	ERJ6GEYJ390	M 39 OHM J 1/10W
R2525	ERJ6GEYJ471	M 470 OHM J 1/10W	R3018	ERJ6GEYJ101	M 100 OHM J 1/10W
R2526	ERJ6GEYJ222	M 2.2KOHM J 1/10W	R3019	ERJ6GEYJ101	M 100 OHM J 1/10W
R2527	ERJ6GEYOR00	M 0 OHM J 1/10W	R3020	ERJ6GEYJ101	M 100 OHM J 1/10W
R2528	ERJ6GEYJ103	M 10KOHM J 1/10W	R3021	ERJ6GEYJ681	M 680 OHM J 1/10W
R2529	ERJ6GEYOR00	M 0 OHM J 1/10W	R3022	ERJ6GEYJ680	M 68 OHM J 1/10W
R2543	ERG3FJ471H	M 470 OHM J 3W	R3023	ERD2FCG560	C 56 OHM 1/4W
R2544	ERG3FJ471H	M 470 OHM J 3W	R3024	ERJ6GEYJ683	M 68KOHM J 1/10W
R2551	ERDS1TJ154	C 150KOHM J 1/2W	R3025	ERJ6GEYJ153	M 15KOHM J 1/10W
R2552	ERDS1TJ184	C 180KOHM J 1/2W	R3026	ERJ6GEYJ221	M 220 OHM J 1/10W
R2553	ERW12PKR33	W 0.33 OHM K 1/2W	R3027	ERJ6GEYJ100	M 10 OHM J 1/10W
R2554	ERD2FCJ4R7P	C 4.7 OHM 1/4W	R3028	ERJ6GEYJ681	M 680 OHM J 1/10W
R2555	ERG2FJ101H	M 100 OHM J 2W	R3029	ERJ6GEYJ100	M 10 OHM J 1/10W
R2556	ERG2FJ101H	M 100 OHM J 2W	R3030	ERJ6GEYJ153	M 15KOHM J 1/10W
△ R2557	TSF19252	PROTECTOR	R3031	ERJ6GEYJ472	M 4.7KOHM J 1/10W
R2558	ERG5FJ473H	M 47KOHM J 5W	R3033	ERJ6GEYJ103	M 10KOHM J 1/10W
R2559	ERD2FCJ4R7P	C 4.7 OHM 1/4W	R3034	ERJ6GEYJ103	M 10KOHM J 1/10W
△ R2567	TSF19402	PROTECTOR	R3035	ERJ6GEYJ103	M 10KOHM J 1/10W
△ R2568	TSF19252	PROTECTOR	R3036	ERJ6GEYJ101	M 100 OHM J 1/10W
R2586	ERG5FJ390H	M 39 OHM J 5W	R3037	ERJ6GEYJ103	M 10KOHM J 1/10W
R2588	ERQ2CJP2R4S	F 2.4 OHM J 2W	R3038	ERJ6GEYJ332	M 3.3KOHM J 1/10W
R2595	ERDS1TJ103	C 10KOHM J 1/2W	R3039	ERJ6GEYJ332	M 3.3KOHM J 1/10W
R2597	ERDS2TJ820	C 82 OHM J 1/4W	R3040	ERJ6GEYJ101	M 100 OHM J 1/10W
R2598	ERDS2TJ102	C 1KOHM J 1/4W	R3041	ERJ6GEYJ101	M 100 OHM J 1/10W
R2599	ERJ6GEYJ153	M 15KOHM J 1/10W	R3042	ERJ6GEYJ101	M 100 OHM J 1/10W
R2610	ERJ6GEYJ471	M 470 OHM J 1/10W	R3043	ERJ6GEYJ471	M 470 OHM J 1/10W
R2611	ERJ6GEYJ103	M 10KOHM J 1/10W	R3044	ERJ6GEYJ100	M 10 OHM J 1/10W
R2612	ERJ6GEYJ103	M 10KOHM J 1/10W	R3045	ERJ6GEYJ680	M 68 OHM J 1/10W
R2613	ERJ6GEYJ272	M 2.7KOHM J 1/10W	R3046	ERJ6GEYJ102	M 1KOHM J 1/10W
R2614	ERJ6GEYJ331	M 330 OHM J 1/10W	R3047	ERJ6GEYJ680	M 68 OHM J 1/10W
R2615	ERJ6GEYJ222	M 2.2KOHM J 1/10W	R3048	ERJ6GEYJ102	M 1KOHM J 1/10W
R2616	ERJ6GEYJ104	M 100KOHM J 1/10W	R3049	ERJ6GEYOR00	M 0 OHM J 1/10W
R2617	ERJ6GEYJ103	M 10KOHM J 1/10W	R3050	ERJ6GEYJ102	M 1KOHM J 1/10W
R2618	ERJ6GEYJ272	M 2.7KOHM J 1/10W	R3051	ERJ6GEYOR00	M 0 OHM J 1/10W
R2619	ERJ6GEYJ331	M 330 OHM J 1/10W	R3052	ERJ6GEYJ102	M 1KOHM J 1/10W
R2630	ERJ6GEYJ223	M 22KOHM J 1/10W	R3053	ERJ6GEYJ220	M 22 OHM J 1/10W
R2631	ERJ6GEYOR00	M 0 OHM J 1/10W	R3054	ERX5FJ3R3H	M 3.3 OHM J 5W
R2632	ERJ6GEYJ681	M 680 OHM J 1/10W	R3055	ERJ6GEYJ151	M 150 OHM J 1/10W
R2633	ERJ6GEYJ223	M 22KOHM J 1/10W	R3056	ERJ6GEYJ151	M 150 OHM J 1/10W
R2634	ERX12SJ1R0	M 0.1 OHM J 1/2W	R3057	ERJ6GEYJ151	M 150 OHM J 1/10W
R2640	ERJ6GEYJ223	M 22KOHM J 1/10W	R3058	ERJ6GEYJ104	M 100KOHM J 1/10W
R2641	ERJ6GEYOR00	M 0 OHM J 1/10W	R3059	ERJ6GEYJ102	M 1KOHM J 1/10W
R2642	ERJ6GEYJ681	M 680 OHM J 1/10W	R3060	ERJ6GEYJ471	M 470 OHM J 1/10W
R2643	ERJ6GEYJ223	M 22KOHM J 1/10W	R3061	ERJ6GEYJ153	M 15KOHM J 1/10W
R2644	ERX12SJ1R0	M 0.1 OHM J 1/2W	R3062	ERJ6GEYJ562	M 5.6KOHM J 1/10W
R2650	ERJ6GEYJ223	M 22KOHM J 1/10W	R3063	ERJ6GEYJ222	M 2.2KOHM J 1/10W
R2651	ERJ6GEYOR00	M 0 OHM J 1/10W	R3064	ERJ6GEYJ272	M 2.7KOHM J 1/10W
R2652	ERJ6GEYJ681	M 680 OHM J 1/10W	R3065	ERJ6GEYJ333	M 33KOHM J 1/10W

Ref. No	Part No.	Description
R3066	ERJ6GEYJ471	M 470 OHM J 1/10W
R3067	ERJ6GEYJ102	M 1KOHM J 1/10W
R3068	ERJ6GEYJ563	M 56KOHM J 1/10W
R3069	ERJ6GEYJ183	M 18KOHM J 1/10W
R3070	ERJ6GEYJ102	M 1KOHM J 1/10W
R3071	ERJ6GEYJ681	M 680 OHM J 1/10W
R3072	ERJ6GEYJ103	M 10KOHM J 1/10W
R3073	ERJ6GEYJ393	M 39KOHM J 1/10W
R3074	ERJ6GEYJ473	M 47KOHM J 1/10W
R3075	ERJ6GEYJ472	M 4.7KOHM J 1/10W
R3076	ERJ6GEYJ331	M 330 OHM J 1/10W
R3077	ERJ6GEYJ101	M 100 OHM J 1/10W
R3078	ERJ6GEY0R00	M 0 OHM J 1/10W
R3079	ERJ6GEYJ101	M 100 OHM J 1/10W
R3080	ERJ6GEYJ101	M 100 OHM J 1/10W
R3081	ERJ6GEYJ101	M 100 OHM J 1/10W
R3082	ERJ6GEYJ101	M 100 OHM J 1/10W
R3083	ERQ2CJP2R2S	F 2.2 OHM J 2W
R3084	ERX5SJ1R2H	M 1.2 OHM J 5W
R3113	ERJ6GEYJ101	M 100 OHM J 1/10W
R3114	ERJ6GEYJ101	M 100 OHM J 1/10W
R3125	ERJ6GEYJ101	M 100 OHM J 1/10W
R3126	ERJ6GEYJ101	M 100 OHM J 1/10W
R3281	ERDS2TJ750	C 75 OHM J 1/4W
R3282	ERDS2TJ750	C 75 OHM J 1/4W
R3284	ERDS2TJ102	C 1KOHM J 1/4W
R3285	ERDS2TJ102	C 1KOHM J 1/4W
R3351	ERDS2TJ683	C 68KOHM J 1/4W
R3352	ERDS2TJ471	C 470 OHM J 1/4W
R3353	ERDS2TJ101	C 100 OHM J 1/4W
R3354	ERDS2TC0	C 0 OHM 1/4W
R3355	ERDS2TJ392	C 3.9KOHM J 1/4W
R3356	ERDS2TJ822	C 8.2KOHM J 1/4W
R3357	ERDS2TJ392	C 3.9KOHM J 1/4W
R3361	ERDS2TJ683	C 68KOHM J 1/4W
R3362	ERDS2TJ471	C 470 OHM J 1/4W
R3363	ERDS2TJ101	C 100 OHM J 1/4W
R3364	ERDS2TC0	C 0 OHM 1/4W
R3365	ERDS2TJ392	C 3.9KOHM J 1/4W
R3366	ERDS2TJ822	C 8.2KOHM J 1/4W
R3367	ERDS2TJ392	C 3.9KOHM J 1/4W
R3371	ERDS2TJ683	C 68KOHM J 1/4W
R3372	ERDS2TJ471	C 470 OHM J 1/4W
R3373	ERDS2TJ101	C 100 OHM J 1/4W
R3374	ERDS2TC0	C 0 OHM 1/4W
R3375	ERDS2TJ392	C 3.9KOHM J 1/4W
R3376	ERDS2TJ822	C 8.2KOHM J 1/4W
R3377	ERDS2TJ392	C 3.9KOHM J 1/4W
R3381	ERDS2TJ104	C 100KOHM J 1/4W
R3382	ERDS2TJ471	C 470 OHM J 1/4W
R3383	ERDS2TJ472	C 4.7KOHM J 1/4W
R3384	ERDS2TJ332	C 3.3KOHM J 1/4W
R3401	ERJ6GEYJ101	M 100 OHM J 1/10W
R3402	ERJ6GEYJ101	M 100 OHM J 1/10W
R3403	ERJ6GEYJ333	M 33KOHM J 1/10W
R3404	ERJ6GEYJ333	M 33KOHM J 1/10W
R3405	ERJ6GEYJ102	M 1KOHM J 1/10W
R3406	ERJ6GEYJ102	M 1KOHM J 1/10W
R3407	ERJ6GEYJ153	M 15KOHM J 1/10W
R3408	ERJ6GEYJ102	M 1KOHM J 1/10W
R3409	ERJ6GEYJ102	M 1KOHM J 1/10W
R3410	ERJ6GEYJ104	M 100KOHM J 1/10W
R3412	ERJ6GEYJ102	M 1KOHM J 1/10W
R3413	ERJ6GEYJ102	M 1KOHM J 1/10W
R3414	ERJ6GEYJ750	M 75 OHM J 1/10W
R3415	ERJ6GEYJ104	M 100KOHM J 1/10W
R3416	ERJ6GEYJ333	M 33KOHM J 1/10W
R3417	ERJ6GEYJ104	M 100KOHM J 1/10W
R3418	ERJ6GEYJ104	M 100KOHM J 1/10W
R3419	ERJ6GEYJ333	M 33KOHM J 1/10W

Ref. No	Part No.	Description
R3420	ERJ6GEYJ750	M 75 OHM J 1/10W
R3421	ERJ6GEYJ750	M 75 OHM J 1/10W
R3422	ERJ6GEYJ153	M 15KOHM J 1/10W
R3423	ERJ6GEYJ470	M 47 OHM J 1/10W
R3424	ERJ6GEYJ101	M 100 OHM J 1/10W
R3425	ERJ6GEYJ221	M 220 OHM J 1/10W
R3426	ERJ6GEYJ680	M 68 OHM J 1/10W
R3427	ERJ6GEYJ102	M 1KOHM J 1/10W
R3428	ERJ6GEYJ680	M 68 OHM J 1/10W
R3429	ERJ6GEYJ100	M 10 OHM J 1/10W
R3430	ERJ6GEYJ103	M 10KOHM J 1/10W
R3431	ERJ6GEYJ101	M 100 OHM J 1/10W
R3432	ERJ6GEYJ221	M 220 OHM J 1/10W
R3433	ERJ6GEYJ332	M 3.3KOHM J 1/10W
R3434	ERJ6GEYJ333	M 33KOHM J 1/10W
R3435	ERJ6GEYJ680	M 68 OHM J 1/10W
R3436	ERJ6GEYJ102	M 1KOHM J 1/10W
R3437	ERJ6GEYJ102	M 1KOHM J 1/10W
R3438	ERJ6GEYJ101	M 100 OHM J 1/10W
R3439	ERJ6GEYJ333	M 33KOHM J 1/10W
R3440	ERJ6GEYJ102	M 1KOHM J 1/10W
R3441	ERJ6GEYJ153	M 15KOHM J 1/10W
R3443	ERJ6GEYJ750	M 75 OHM J 1/10W
R3444	ERJ6GEYJ470	M 47 OHM J 1/10W
R3445	ERJ6GEYJ750	M 75 OHM J 1/10W
R3446	ERJ6GEYJ102	M 1KOHM J 1/10W
R3447	ERJ6GEYJ102	M 1KOHM J 1/10W
R3452	ERJ6GEYJ101	M 100 OHM J 1/10W
R3453	ERJ6GEYJ101	M 100 OHM J 1/10W
R3454	ERJ6GEYJ101	M 100 OHM J 1/10W
R3455	ERJ6GEYJ101	M 100 OHM J 1/10W
R6701	ERC12ZGK335	S 3.3MOHM K 1/2W
R6704	ERF2AK5R6	W 5.6 OHM K 2W
R6705	ERG1FJS104D	M 100KOHM J 1W
R6708	ERDS2TJ101	C 100 OHM J 1/4W
R6751	ERDS2TJ273	C 27KOHM J 1/4W
R6752	ERDS2TJ682	C 6.8KOHM J 1/4W
R6753	ERDS2TJ122	C 1.2KOHM J 1/4W
R6754	ERDS2TJ182	C 1.8KOHM J 1/4W
R6755	ERDS2TJ471	C 470 OHM J 1/4W
R6763	ERDS1TJ102	C 1KOHM J 1/2W
R6764	ERDS1TJ122	C 1.2KOHM J 1/2W
R6766	ERDS1TJ330	C 33 OHM J 1/2W
R7001	EROS2CKF20R0	M 20 OHM F 1/4W
R7002	EROS2CKF20R0	M 20 OHM F 1/4W
R7003	EROS2CKF20R0	M 20 OHM F 1/4W
R7004	EROS2CKF20R0	M 20 OHM F 1/4W
R7005	EROS2CKF20R0	M 20 OHM F 1/4W
R7006	EROS2CKF20R0	M 20 OHM F 1/4W
R7007	EROS2CKF20R0	M 20 OHM F 1/4W
R7008	EROS2CKF20R0	M 20 OHM F 1/4W
R7009	EROS2CKF20R0	M 20 OHM F 1/4W
R7010	EROS2CKF20R0	M 20 OHM F 1/4W
R7011	EROS2CKF20R0	M 20 OHM F 1/4W
R7012	EROS2CKF20R0	M 20 OHM F 1/4W
R7013	EROS2CKF20R0	M 20 OHM F 1/4W
R7014	EROS2CKF20R0	M 20 OHM F 1/4W
R7015	EROS2CKF20R0	M 20 OHM F 1/4W
R7016	EROS2CKF20R0	M 20 OHM F 1/4W
R7019	EROS2CKF10R0	M 10 OHM F 1/4W
R7020	EROS2CKF10R0	M 10 OHM F 1/4W
R7021	EROS2CKF10R0	M 10 OHM F 1/4W
R7022	EROS2CKF10R0	M 10 OHM F 1/4W
R7027	ERDS2TJ332	C 3.3KOHM J 1/4W
R7028	ERDS2TJ332	C 3.3KOHM J 1/4W
R7029	ERDS2TJ561	C 560 OHM J 1/4W
R7030	ERDS2TJ332	C 3.3KOHM J 1/4W
R7031	ERDS2TJ332	C 3.3KOHM J 1/4W
R7032	ERDS2TJ332	C 3.3KOHM J 1/4W
R7033	ERDS2TJ561	C 560 OHM J 1/4W

Ref. No	Part No.	Description	Ref. No	Part No.	Description
R7035	ERDS2TJ332	C 3.3KOHM J 1/4W	R7151	ERJ6GEYJ682	M 6.8KOHM J 1/10W
R7036	ERDS2TJ561	C 560 OHM J 1/4W	R7152	ERJ6GEYJ103	M 10KOHM J 1/10W
R7039	ERDS2TJ332	C 3.3KOHM J 1/4W	R7153	ERJ6GEYJ103	M 10KOHM J 1/10W
R7040	ERDS2TJ561	C 560 OHM J 1/4W	R7154	ERJ6GEYJ103	M 10KOHM J 1/10W
R7041	ERDS2TJ332	C 3.3KOHM J 1/4W	R7155	ERJ6GEYJ103	M 10KOHM J 1/10W
R7042	ERDS2TJ561	C 560 OHM J 1/4W	R7156	ERJ6GEYJ103	M 10KOHM J 1/10W
R7043	ERDS2TJ561	C 560 OHM J 1/4W	R7157	ERJ6GEYJ103	M 10KOHM J 1/10W
R7044	ERDS2TJ332	C 3.3KOHM J 1/4W	R7158	ERJ6GEYJ103	M 10KOHM J 1/10W
R7045	ERG2SJ820H	M 82 OHM J 2W	R7159	ERJ6GEYJ103	M 10KOHM J 1/10W
R7046	ERG2SJ121H	M 120 OHM J 2W	R7160	ERJ6GEYJ103	M 10KOHM J 1/10W
R7047	ERG2SJ820H	M 82 OHM J 2W	R7161	ERJ6GEYJ103	M 10KOHM J 1/10W
R7048	ER0S2CKF10R0	M 10 OHM F 1/4W	R7162	ERJ6GEYJ103	M 10KOHM J 1/10W
R7049	ER0S2CKF10R0	M 10 OHM F 1/4W	R7163	ERJ6GEYJ103	M 10KOHM J 1/10W
R7050	ER0S2CKF10R0	M 10 OHM F 1/4W	R7164	ERJ6GEYJ103	M 10KOHM J 1/10W
R7051	ER0S2CKF10R0	M 10 OHM F 1/4W	R7165	ERJ6GEYJ103	M 10KOHM J 1/10W
R7056	ERG2SJ820H	M 82 OHM J 2W	R7166	ERJ6GEYJ103	M 10KOHM J 1/10W
R7057	ERDS2TJ332	C 3.3KOHM J 1/4W	R7168	ERJ6GEY0R00	M 0 OHM J 1/10W
R7058	ERDS2TJ561	C 560 OHM J 1/4W	R7172	ERJ6GEYJ103	M 10KOHM J 1/10W
R7059	ERDS2TJ561	C 560 OHM J 1/4W	R7173	ERJ6GEYJ103	M 10KOHM J 1/10W
R7060	ERDS2TJ332	C 3.3KOHM J 1/4W	R7174	ERJ6GEY0R00	M 0 OHM J 1/10W
R7061	ERDS2TJ561	C 560 OHM J 1/4W	R7175	ERJ6GEYJ103	M 10KOHM J 1/10W
R7062	ERDS2TJ332	C 3.3KOHM J 1/4W	R7177	ERJ6GEYJ103	M 10KOHM J 1/10W
R7063	ER0S2CKF10R0	M 10 OHM F 1/4W	R7178	ERJ6GEYJ103	M 10KOHM J 1/10W
R7064	ER0S2CKF10R0	M 10 OHM F 1/4W	R7182	ERJ6GEYJ562	M 5.6KOHM J 1/10W
R7065	ER0S2CKF10R0	M 10 OHM F 1/4W	R7183	ERJ6GEYJ562	M 5.6KOHM J 1/10W
R7066	ER0S2CKF10R0	M 10 OHM F 1/4W	R7184	ERJ6GEYJ103	M 10KOHM J 1/10W
R7073	ERG2SJ820H	M 82 OHM J 2W	R7186	ERJ6GEYJ103	M 10KOHM J 1/10W
R7074	ERDS2TJ561	C 560 OHM J 1/4W	R7188	ERJ6GEYJ103	M 10KOHM J 1/10W
R7075	ERDS2TJ561	C 560 OHM J 1/4W	R7189	ERJ6GEYJ103	M 10KOHM J 1/10W
R7076	ERDS2TJ332	C 3.3KOHM J 1/4W	R7190	ERJ6GEYJ103	M 10KOHM J 1/10W
R7077	ERDS2TJ332	C 3.3KOHM J 1/4W	R7191	ERJ6GEYJ103	M 10KOHM J 1/10W
R7078	ERDS2TJ332	C 3.3KOHM J 1/4W	R7192	ERJ6GEYJ103	M 10KOHM J 1/10W
R7080	ERG2SJ121H	M 120 OHM J 2W	R7193	ERJ6GEYJ103	M 10KOHM J 1/10W
R7081	ERDS2TJ561	C 560 OHM J 1/4W	R7194	ERJ6GEYJ123	M 12KOHM J 1/10W
R7082	ERDS2TJ332	C 3.3KOHM J 1/4W	R7197	ERJ6GEYJ103	M 10KOHM J 1/10W
R7083	ER0S2CKF20R0	M 20 OHM F 1/4W	R7200	ERJ6GEY0R00	M 0 OHM J 1/10W
R7084	ER0S2CKF20R0	M 20 OHM F 1/4W	R7202	ERJ6GEYJ103	M 10KOHM J 1/10W
R7085	ER0S2CKF20R0	M 20 OHM F 1/4W	R7206	ERJ6GEY0R00	M 0 OHM J 1/10W
R7086	ER0S2CKF20R0	M 20 OHM F 1/4W	R7207	ERJ6GEYJ103	M 10KOHM J 1/10W
R7087	ER0S2CKF20R0	M 20 OHM F 1/4W	R7210	ERJ6GEY0R00	M 0 OHM J 1/10W
R7088	ER0S2CKF20R0	M 20 OHM F 1/4W	R7211	ERJ6GEYJ103	M 10KOHM J 1/10W
R7089	ER0S2CKF20R0	M 20 OHM F 1/4W	R7213	ERJ6GEYJ103	M 10KOHM J 1/10W
R7090	ER0S2CKF20R0	M 20 OHM F 1/4W	R7215	ERJ6GEYJ103	M 10KOHM J 1/10W
R7091	ERDS2TJ332	C 3.3KOHM J 1/4W	R7217	ERJ6GEYJ103	M 10KOHM J 1/10W
R7092	ERDS2TJ332	C 3.3KOHM J 1/4W	R7219	ERJ6GEYJ103	M 10KOHM J 1/10W
R7107	ERJ6GEYJ331	M 330 OHM J 1/10W	R7222	ERJ6GEYJ122	M 1.2KOHM J 1/10W
R7108	ERJ6GEYJ331	M 330 OHM J 1/10W	R7226	ERJ6GEYJ331	M 330 OHM J 1/10W
R7109	ERJ6GEYJ331	M 330 OHM J 1/10W	R7227	ERJ6GEYJ122	M 1.2KOHM J 1/10W
R7112	ERJ6GEYJ331	M 330 OHM J 1/10W	R7231	ERJ6GEYJ331	M 330 OHM J 1/10W
R7113	ERJ6GEYJ331	M 330 OHM J 1/10W	R7233	ERJ6GEYJ122	M 1.2KOHM J 1/10W
R7114	ERJ6GEY0R00	M 0 OHM J 1/10W	R7236	ERJ6GEYJ331	M 330 OHM J 1/10W
R7121	ERJ6GEYJ103	M 10KOHM J 1/10W	R7241	ERJ6GEYJ102	M 1KOHM J 1/10W
R7122	ERJ6GEYJ103	M 10KOHM J 1/10W	R7245	ERJ6GEYJ122	M 1.2KOHM J 1/10W
R7127	ERJ6GEYJ103	M 10KOHM J 1/10W	R7246	ERJ6GEY0R00	M 0 OHM J 1/10W
R7130	ERJ6GEYJ103	M 10KOHM J 1/10W	R7247	ERJ6GEYJ221	M 220 OHM J 1/10W
R7131	ERJ6GEYJ103	M 10KOHM J 1/10W	R7248	ERJ6GEYJ221	M 220 OHM J 1/10W
R7132	ERJ6GEYJ103	M 10KOHM J 1/10W	R7249	ERJ6GEYJ221	M 220 OHM J 1/10W
R7133	ERJ6GEYJ684	M 680KOHM J 1/10W	R7250	ERJ6GEYJ221	M 220 OHM J 1/10W
R7134	ERJ6GEY0R00	M 0 OHM J 1/10W	R7251	ERJ6GEYJ121	M 120 OHM J 1/10W
R7136	ERJ6GEYJ103	M 10KOHM J 1/10W	R7253	ERJ6GEYJ223	M 22KOHM J 1/10W
R7138	ERJ6GEY0R00	M 0 OHM J 1/10W	R7254	ERJ6GEYJ223	M 22KOHM J 1/10W
R7139	ERJ6GEYJ103	M 10KOHM J 1/10W	R7255	ERJ6ENF2001	M 2KOHM 1/10W
R7140	ERJ6GEYJ221	M 220 OHM J 1/10W	R7256	ERJ6GEYJ223	M 22KOHM J 1/10W
R7142	ERJ6GEYJ103	M 10KOHM J 1/10W	R7257	ERJ6GEYJ223	M 22KOHM J 1/10W
R7143	ERJ6GEYJ392	M 3.9KOHM J 1/10W	R7259	ERJ6ENF2001	M 2KOHM 1/10W
R7144	ERJ6GEY0R00	M 0 OHM J 1/10W	R7261	ERJ6ENF2001	M 2KOHM 1/10W
R7145	ERJ6GEY0R00	M 0 OHM J 1/10W	R7262	ERJ6GEYJ223	M 22KOHM J 1/10W
R7148	ERJ6GEYJ103	M 10KOHM J 1/10W	R7263	ERJ6GEYJ223	M 22KOHM J 1/10W
R7149	ERJ6GEYJ103	M 10KOHM J 1/10W	R7264	ERJ6ENF1201	M 1.2KOHM 1/10W
R7150	ERJ6GEYJ222	M 2.2KOHM J 1/10W	R7265	ERJ6ENF1201	M 1.2KOHM 1/10W

Ref. No	Part No.	Description		
R7266	ERJ6ENF1201	M 1.2KOHM	1/10W	
R7267	ERJ6ENF1201	M 1.2KOHM	1/10W	
R7268	ERJ6ENF1201	M 1.2KOHM	1/10W	
R7269	ERJ6ENF1201	M 1.2KOHM	1/10W	
R7276	ERJ6ENF6652	M 66.5KOHM	1/10W	
R7277	ERJ6ENF6652	M 66.5KOHM	1/10W	
R7278	ERJ6ENF6652	M 66.5KOHM	1/10W	
R7280	ERJ6GEYJ102	M 1KOHM J	1/10W	
R7281	ERJ6GEYJ102	M 1KOHM J	1/10W	
R7282	ERJ6GEYJ102	M 1KOHM J	1/10W	
R7283	ERJ6ENF1003	M 100KOHM	1/10W	
R7284	ERJ6ENF1003	M 100KOHM	1/10W	
R7285	ERJ6ENF1003	M 100KOHM	1/10W	
R7286	ERJ6ENF4302	M 43KOHM	1/10W	
R7287	ERJ6ENF4302	M 43KOHM	1/10W	
R7288	ERJ6ENF4302	M 43KOHM	1/10W	
R7289	ERJ6ENF4302	M 43KOHM	1/10W	
R7290	ERJ6ENF1003	M 100KOHM	1/10W	
R7291	ERJ6ENF4302	M 43KOHM	1/10W	
R7292	ERJ6ENF1003	M 100KOHM	1/10W	
R7293	ERJ6ENF4302	M 43KOHM	1/10W	
R7294	ERJ6ENF1003	M 100KOHM	1/10W	
R7295	ERJ6GEYJ102	M 1KOHM J	1/10W	
R7296	ERJ6GEYJ102	M 1KOHM J	1/10W	
R7297	ERJ6GEYJ102	M 1KOHM J	1/10W	
R7298	ERJ6GEYJ561	M 560 OHM J	1/10W	
R7299	ERJ6ENF6652	M 66.5KOHM	1/10W	
R7300	ERJ6ENF6652	M 66.5KOHM	1/10W	
R7301	ERJ6ENF6652	M 66.5KOHM	1/10W	
R7308	ERJ6GEYJ561	M 560 OHM J	1/10W	
R7309	ERJ6GEYJ561	M 560 OHM J	1/10W	
R7310	ERJ6GEYJ561	M 560 OHM J	1/10W	
R7311	ERJ6GEYJ561	M 560 OHM J	1/10W	
R7312	ERJ6GEYJ561	M 560 OHM J	1/10W	
R7313	ERJ6GEY0R00	M 0 OHM J	1/10W	
R7315	ERJ6GEY0R00	M 0 OHM J	1/10W	
R7316	ERJ6GEY0R00	M 0 OHM J	1/10W	
R7317	ERJ6GEY0R00	M 0 OHM J	1/10W	
R7318	ERJ6GEY0R00	M 0 OHM J	1/10W	
R7319	ERJ6GEYJ151	M 150 OHM J	1/10W	
R7320	ERJ6GEYJ151	M 150 OHM J	1/10W	
R7321	ERJ6GEYJ151	M 150 OHM J	1/10W	
R7322	ERJ6GEYJ680	M 68 OHM J	1/10W	
R7323	ERJ6GEY0R00	M 0 OHM J	1/10W	
R7326	ERJ6GEYJ102	M 1KOHM J	1/10W	
R7334	ERJ6GEYJ102	M 1KOHM J	1/10W	
R7335	ERJ6GEYJ103	M 10KOHM J	1/10W	
R7340	ERJ6GEYJ105	M 1MOHM J	1/10W	
R7341	ERJ6GEYJ102	M 1KOHM J	1/10W	
R7347	ERJ6GEYJ471	M 470 OHM J	1/10W	
R7348	ERJ6GEYJ102	M 1KOHM J	1/10W	
R7349	ERJ6GEYJ102	M 1KOHM J	1/10W	
R7350	ERJ6GEYJ102	M 1KOHM J	1/10W	
R7359	ERJ6GEYJ102	M 1KOHM J	1/10W	
R7360	ERJ6GEYJ102	M 1KOHM J	1/10W	
R7363	ERJ6GEY0R00	M 0 OHM J	1/10W	
R7369	ERJ6GEYJ102	M 1KOHM J	1/10W	
R7370	ERJ6GEYJ102	M 1KOHM J	1/10W	
R7384	ERJ6GEY0R00	M 0 OHM J	1/10W	
R7385	ERJ6GEY0R00	M 0 OHM J	1/10W	
R7386	ERJ6GEY0R00	M 0 OHM J	1/10W	
R7402	ERJ6ENF2001	M 2KOHM	1/10W	
R7403	ERJ6GEYJ223	M 22KOHM J	1/10W	
R7404	ERJ6GEYJ223	M 22KOHM J	1/10W	
R7406	ERJ6ENF2001	M 2KOHM	1/10W	
R7407	ERJ6GEYJ223	M 22KOHM J	1/10W	
R7408	ERJ6GEYJ223	M 22KOHM J	1/10W	
R7410	ERJ6ENF2001	M 2KOHM	1/10W	
R7411	ERJ6GEYJ223	M 22KOHM J	1/10W	
R7412	ERJ6GEYJ223	M 22KOHM J	1/10W	

Ref. No	Part No.	Description		
R7413	ERJ6GEYJ563	M 56KOHM J	1/10W	
R7414	ERJ6GEYJ562	M 5.6KOHM J	1/10W	
R7415	ERJ6GEYJ473	M 47KOHM J	1/10W	
R7416	ERJ6GEYJ563	M 56KOHM J	1/10W	
R7417	ERJ6GEYJ562	M 5.6KOHM J	1/10W	
R7418	ERJ6GEYJ563	M 56KOHM J	1/10W	
R7419	ERJ6GEYJ821	M 820 OHM J	1/10W	
R7420	ERJ6GEYJ821	M 820 OHM J	1/10W	
R7421	ERJ6GEYJ821	M 820 OHM J	1/10W	
R7429	ERJ6GEY0R00	M 0 OHM J	1/10W	
R7430	ERJ6ENF1001	M 1KOHM	1/10W	
R7431	ERJ6GEY0R00	M 0 OHM J	1/10W	
R7432	ERJ6ENF1001	M 1KOHM	1/10W	
R7433	ERJ6GEY0R00	M 0 OHM J	1/10W	
R7434	ERJ6ENF1001	M 1KOHM	1/10W	
R7435	ERJ6GEYJ561	M 560 OHM J	1/10W	
R7436	ERJ6GEYJ561	M 560 OHM J	1/10W	
R7449	ERJ6GEY0R00	M 0 OHM J	1/10W	
R7455	ERJ6ENF6801	M 6.8KOHM	1/10W	
R7456	ERJ6ENF3301	M 3.3KOHM	1/10W	
R7457	ERJ6ENF6801	M 6.8KOHM	1/10W	
R7458	ERJ6ENF3301	M 3.3KOHM	1/10W	
R7460	ERJ6ENF6801	M 6.8KOHM	1/10W	
R7461	ERJ6ENF3301	M 3.3KOHM	1/10W	
R7462	ERJ6ENF6801	M 6.8KOHM	1/10W	
R7463	ERJ6ENF3301	M 3.3KOHM	1/10W	
R7465	ERJ6ENF6801	M 6.8KOHM	1/10W	
R7466	ERJ6ENF3301	M 3.3KOHM	1/10W	
R7467	ERJ6ENF6801	M 6.8KOHM	1/10W	
R7468	ERJ6GEYJ332	M 3.3KOHM J	1/10W	
R7469	ERJ6GEYJ103	M 10KOHM J	1/10W	
R7470	ERJ6GEYJ103	M 10KOHM J	1/10W	
R7471	ERJ6GEYJ102	M 1KOHM J	1/10W	
R7472	ERJ6GEYJ122	M 1.2KOHM J	1/10W	
R7474	ERJ6GEY0R00	M 0 OHM J	1/10W	
R7475	ERJ6GEY0R00	M 0 OHM J	1/10W	
R7476	ERJ6GEY0R00	M 0 OHM J	1/10W	
R7487	ERJ6ENF1472	M 14.7KOHM	1/10W	
R7488	ERJ6ENF1502	M 15KOHM	1/10W	
R7489	ERJ6GEYJ102	M 1KOHM J	1/10W	
R7502	ERDS2TJ563	C 56KOHM J	1/4W	
R7503	ERDS2TJ101	C 100 OHM J	1/4W	
R7504	ERDS2TJ153	C 15KOHM J	1/4W	
R7505	ERDS2TJ223	C 22KOHM J	1/4W	
R7507	ERDS2TJ471	C 470 OHM J	1/4W	
R7514	ERDS2TJ102	C 1KOHM J	1/4W	
R7515	ERDS1FJ220	C 22 OHM J	1/2W	
R7516	ERDS1FJ5R6	C 5.6 OHM J	1/2W	
R7517	ERDS1FJ470	C 47 OHM J	1/2W	
R7518	ERX12SJR47P	M 0.47 OHM J	1/2W	
R7519	ERX12SJR47P	M 0.47 OHM J	1/2W	
R7521	ERG3FJ153H	M 15KOHM J	3W	
R7522	ERG3FJ153H	M 15KOHM J	3W	
R7523	ERDS2TJ274	C 270KOHM J	1/4W	
R7524	ERDS1FJ331	C 330 OHM J	1/2W	
R7525	ERDS1FJ331	C 330 OHM J	1/2W	
R7540	ERQ14AJ101P	F 100 OHM J	1/4W	
R7541	ERQ14AJ101P	F 100 OHM J	1/4W	
R7542	ERQ14AJ101P	F 100 OHM J	1/4W	
R7543	ERQ14AJ101P	F 100 OHM J	1/4W	
R7544	ERX3FJS4R7D	M 4.7 OHM J	3W	
R7545	ERQ14AJ101P	F 100 OHM J	1/4W	
R7546	ERQ14AJ101P	F 100 OHM J	1/4W	
R7547	ERQ14AJ101P	F 100 OHM J	1/4W	
R7548	ERQ14AJ101P	F 100 OHM J	1/4W	
R7549	ERX2FJS4R7D	M 4.7 OHM J	2W	
R7550	ERDS2TJ270	C 27 OHM J	1/4W	
R7551	ERDS2TJ392	C 3.9KOHM J	1/4W	
R7552	ERDS2TJ332	C 3.3KOHM J	1/4W	
R7553	ERDS2TJ562	C 5.6KOHM J	1/4W	

Ref. No	Part No.	Description	Ref. No	Part No.	Description
R7554	ERDS2TJ562	C 5.6KOHM J 1/4W	R7743	ERJ6GEYJ101	M 100 OHM J 1/10W
R7556	ERDS2TJ472	C 4.7KOHM J 1/4W	R7744	ERJ6GEYJ562	M 5.6KOHM J 1/10W
R7557	ERDS2TJ182	C 1.8KOHM J 1/4W	R7745	ERJ6GEYJ182	M 1.8KOHM J 1/10W
R7558	ERDS2TJ182	C 1.8KOHM J 1/4W	R7746	ERJ6GEYJ103	M 10KOHM J 1/10W
R7559	ERDS2TJ103	C 10KOHM J 1/4W	R7747	ERJ6GEYJ332	M 3.3KOHM J 1/10W
R7560	ERDS2TJ103	C 10KOHM J 1/4W	R7749	ERJ6GEYJ103	M 10KOHM J 1/10W
R7561	ERDS2TJ104	C 100KOHM J 1/4W	R7750	ERJ6GEYJ103	M 10KOHM J 1/10W
R7562	ERDS2TJ103	C 10KOHM J 1/4W	R7751	ERJ6GEYJ103	M 10KOHM J 1/10W
R7563	ERDS2TJ103	C 10KOHM J 1/4W	R7752	ERJ6GEYJ103	M 10KOHM J 1/10W
R7564	ERDS2TJ103	C 10KOHM J 1/4W	R7753	ERJ6GEYJ152	M 1.5KOHM J 1/10W
R7565	ERDS2TJ103	C 10KOHM J 1/4W	R7754	ERJ6GEYJ104	M 100KOHM J 1/10W
R7566	ERDS2TJ102	C 1KOHM J 1/4W	R7755	ERJ6GEYJ152	M 1.5KOHM J 1/10W
R7567	ERDS2TJ103	C 10KOHM J 1/4W	R7756	ERJ6GEYJ102	M 1KOHM J 1/10W
R7569	ERDS2TJ392	C 3.9KOHM J 1/4W	R7757	ERJ6GEYJ221	M 220 OHM J 1/10W
R7570	ERDS2TJ122	C 1.2KOHM J 1/4W	R7758	ERJ6GEYJ221	M 220 OHM J 1/10W
R7571	ERX1SJR39	M 0.39 OHM J 1W	R7759	ERJ6GEYJ221	M 220 OHM J 1/10W
R7572	ERDS2TJ471	C 470 OHM J 1/4W	R7760	ERJ6ENF3742	M 37.4KOHM 1/10W
R7573	ERDS2TJ102	C 1KOHM J 1/4W	R7761	ERJ6GEYJ102	M 1KOHM J 1/10W
R7574	ERDS2TJ103	C 10KOHM J 1/4W	R7762	ERJ6ENF2702	M 27KOHM 1/10W
R7575	ERX1SJR39	M 0.39 OHM J 1W	R7763	ERJ6GEYJ123	M 12KOHM J 1/10W
R7576	ERDS2TJ122	C 1.2KOHM J 1/4W	R7764	ERJ6GEYJ122	M 1.2KOHM J 1/10W
R7577	ERDS2TJ222	C 2.2KOHM J 1/4W	R7765	ERJ6GEYJ152	M 1.5KOHM J 1/10W
R7580	ER0S2CKF1822	M 18.2KOHM F 1/4W	R7766	ERJ6GEYJ152	M 1.5KOHM J 1/10W
R7581	ER0S2CKF2321	M 2.32KOHM F 1/4W	R7767	ERJ6GEYJ102	M 1KOHM J 1/10W
R7582	ERDS2TJ332	C 3.3KOHM J 1/4W	R7768	ERJ6GEYJ272	M 2.7KOHM J 1/10W
R7583	ERDS2TJ152	C 1.5KOHM J 1/4W	R7769	ERJ6GEYJ271	M 270 OHM J 1/10W
R7584	ERDS2TJ101	C 100 OHM J 1/4W	R7772	ERJ6ENF5601	M 5.6KOHM 1/10W
R7585	ERDS2TJ472	C 4.7KOHM J 1/4W	R7773	ERJ6ENF4701	M 4.7KOHM 1/10W
R7701	ERJ6GEYJ103	M 10KOHM J 1/10W	R7774	ERJ6GEYJ103	M 10KOHM J 1/10W
R7702	ERJ6GEYJ682	M 6.8KOHM J 1/10W	R7775	ERJ6GEYJ562	M 5.6KOHM J 1/10W
R7703	ERJ6GEYJ102	M 1KOHM J 1/10W	R7783	ERJ6ENF1102	M 11KOHM 1/10W
R7704	ERJ6GEYJ221	M 220 OHM J 1/10W	R7784	ERJ6ENF5101	M 5.1KOHM 1/10W
R7705	ERJ6GEYJ221	M 220 OHM J 1/10W	R7785	ERJ6GEYJ333	M 33KOHM J 1/10W
R7706	ERJ6GEYJ272	M 2.7KOHM J 1/10W	R7787	ERJ6GEYJ333	M 33KOHM J 1/10W
R7707	ERJ6GEYJ333	M 33KOHM J 1/10W	R7788	ERJ6ENF2322	M 23.2KOHM 1/10W
R7708	ERJ6GEYJ561	M 560 OHM J 1/10W	R7789	ERJ6ENF1802	M 18KOHM 1/10W
R7709	ERJ6ENF3600	M 360 OHM 1/10W	R7792	ERJ6GEY0R00	M 0 OHM J 1/10W
R7710	ERJ6GEYJ561	M 560 OHM J 1/10W	R7793	ERJ6ENF1002	M 10KOHM 1/10W
R7711	ERJ6ENF3600	M 360 OHM 1/10W	R7794	ERJ6ENF2001	M 2KOHM 1/10W
R7712	ERJ6GEYJ823	M 82KOHM J 1/10W	R7798	ERJ6GEY0R00	M 0 OHM J 1/10W
R7713	ERJ6GEYJ103	M 10KOHM J 1/10W	R7801	ERJ6GEY0R00	M 0 OHM J 1/10W
R7714	ERJ6GEYJ221	M 220 OHM J 1/10W	R7802	ERJ6GEY0R00	M 0 OHM J 1/10W
R7715	ERJ6GEYJ221	M 220 OHM J 1/10W	R7803	ERJ6GEYJ471	M 470 OHM J 1/10W
R7716	ERJ6GEYJ332	M 3.3KOHM J 1/10W	R7808	ERJ6GEYJ471	M 470 OHM J 1/10W
R7717	ERJ6GEYJ223	M 22KOHM J 1/10W	R7809	ERJ6GEYJ471	M 470 OHM J 1/10W
R7718	ERJ6GEYJ151	M 150 OHM J 1/10W	R7810	ERJ6GEYJ471	M 470 OHM J 1/10W
R7719	ERJ6GEYJ101	M 100 OHM J 1/10W	R7811	ERJ6GEYJ681	M 680 OHM J 1/10W
R7720	ERJ6GEYJ561	M 560 OHM J 1/10W	R7813	ERJ6GEYJ122	M 1.2KOHM J 1/10W
R7721	ERJ6ENF3600	M 360 OHM 1/10W	R7814	ERJ6GEYJ122	M 1.2KOHM J 1/10W
R7722	ERJ6GEYJ561	M 560 OHM J 1/10W	R7815	ERJ6GEYJ472	M 4.7KOHM J 1/10W
R7723	ERJ6ENF3600	M 360 OHM 1/10W	R7816	ERJ6GEYJ122	M 1.2KOHM J 1/10W
R7724	ERJ6GEYJ391	M 390 OHM J 1/10W	R7817	ERJ6GEYJ221	M 220 OHM J 1/10W
R7725	ERJ6GEYJ102	M 1KOHM J 1/10W	R7818	ERJ6GEYJ472	M 4.7KOHM J 1/10W
R7726	ERJ6GEYJ221	M 220 OHM J 1/10W	R7819	ERJ6GEY0R00	M 0 OHM J 1/10W
R7727	ERJ6GEYJ221	M 220 OHM J 1/10W	R7820	ERJ6GEYJ472	M 4.7KOHM J 1/10W
R7728	ERJ6GEYJ562	M 5.6KOHM J 1/10W	R7821	ERJ6GEYJ472	M 4.7KOHM J 1/10W
R7729	ERJ6GEYJ561	M 560 OHM J 1/10W	R7822	ERJ6GEYJ222	M 2.2KOHM J 1/10W
R7730	ERJ6ENF3600	M 360 OHM 1/10W	R7824	ERJ6GEYJ221	M 220 OHM J 1/10W
R7731	ERJ6GEYJ561	M 560 OHM J 1/10W	R7825	ERJ6GEYJ221	M 220 OHM J 1/10W
R7732	ERJ6ENF3600	M 360 OHM 1/10W	R7826	ERJ6GEYJ101	M 100 OHM J 1/10W
R7733	ERJ6GEYJ683	M 68KOHM J 1/10W	R7828	ERJ6ENF1201	M 1.2KOHM 1/10W
R7734	ERJ6GEYJ103	M 10KOHM J 1/10W	R7829	ERJ6ENF3901	M 3.9KOHM 1/10W
R7735	ERJ6GEYJ101	M 100 OHM J 1/10W	R7830	ERJ6ENF1000	M 100 OHM 1/10W
R7736	ERJ6GEYJ101	M 100 OHM J 1/10W	R7831	ERJ6GEYJ181	M 180 OHM J 1/10W
R7737	ERJ6GEYJ682	M 6.8KOHM J 1/10W	R7832	ERJ6ENF4700	M 470 OHM 1/10W
R7738	ERJ6GEYJ821	M 820 OHM J 1/10W	R7833	ERJ6ENF2000	M 200 OHM 1/10W
R7739	ERJ6GEYJ473	M 47KOHM J 1/10W	R7834	ERJ6GEYJ181	M 180 OHM J 1/10W
R7740	ERJ6GEYJ223	M 22KOHM J 1/10W	R7835	ERJ6GEYJ181	M 180 OHM J 1/10W
R7741	ERJ6GEYJ822	M 8.2KOHM J 1/10W	R7836	ERJ6GEYJ682	M 6.8KOHM J 1/10W
R7742	ERJ6GEYJ122	M 1.2KOHM J 1/10W	R7838	ERJ6GEYJ102	M 1KOHM J 1/10W

Ref. No	Part No.	Description
R7839	ERJ6GEYJ563	M 56KOHM J 1/10W
R7840	ERJ6GEYJ152	M 1.5KOHM J 1/10W
R7841	ERJ6GEYJ100	M 10 OHM J 1/10W
R7842	ERJ6GEYJ100	M 10 OHM J 1/10W
R7843	ERJ6GEYJ100	M 10 OHM J 1/10W
R7844	ERJ6GEYJ101	M 100 OHM J 1/10W
R7845	ERJ6GEYJ101	M 100 OHM J 1/10W
R7846	ERJ6GEYJ101	M 100 OHM J 1/10W
R7847	ERJ6GEYJ560	M 56 OHM J 1/10W
R7848	ERJ6GEYJ101	M 100 OHM J 1/10W
R7849	ERJ6GEYJ101	M 100 OHM J 1/10W
R7850	ERJ6GEYJ101	M 100 OHM J 1/10W
R7851	ERJ6GEYJ331	M 330 OHM J 1/10W
R7852	ERJ6GEYJ101	M 100 OHM J 1/10W
R7853	ERJ6GEYJ101	M 100 OHM J 1/10W
R7854	ERJ6GEYJ221	M 220 OHM J 1/10W
R7855	ERJ6GEYJ152	M 1.5KOHM J 1/10W
R7856	ERJ6GEYJ472	M 4.7KOHM J 1/10W
R7857	ERJ6GEY0R00	M 0 OHM J 1/10W
R7858	ERJ6GEYJ472	M 4.7KOHM J 1/10W
R7859	ERJ6GEYJ222	M 2.2KOHM J 1/10W
R7861	ERJ6GEYJ332	M 3.3KOHM J 1/10W
R7862	ERJ6GEYJ683	M 68KOHM J 1/10W
R7863	ERJ6GEYJ103	M 10KOHM J 1/10W
R7864	ERJ6GEYJ102	M 1KOHM J 1/10W
R7865	ERJ6GEYJ473	M 47KOHM J 1/10W
R7866	ERJ6GEYJ103	M 10KOHM J 1/10W
R7867	ERJ6GEYJ562	M 5.6KOHM J 1/10W
R7868	ERJ6GEYJ103	M 10KOHM J 1/10W
R7869	ERJ6GEYJ103	M 10KOHM J 1/10W
R7870	ERJ6GEYJ103	M 10KOHM J 1/10W
R7873	ERJ6GEYJ331	M 330 OHM J 1/10W
R7874	ERJ6GEYJ331	M 330 OHM J 1/10W
R7879	ERJ6GEYJ103	M 10KOHM J 1/10W
R7880	ERJ6GEY0R00	M 0 OHM J 1/10W
R7881	ERJ6GEY0R00	M 0 OHM J 1/10W
R7882	ERJ6GEY0R00	M 0 OHM J 1/10W
R7883	ERJ6GEY0R00	M 0 OHM J 1/10W
R7884	ERJ6GEY0R00	M 0 OHM J 1/10W
R7885	ERJ6GEYJ472	M 4.7KOHM J 1/10W
R7886	ERJ6GEYJ472	M 4.7KOHM J 1/10W
R7887	ERJ6GEYJ472	M 4.7KOHM J 1/10W
R7889	ERJ6GEYJ102	M 1KOHM J 1/10W
R7890	ERJ6GEYJ102	M 1KOHM J 1/10W
R7891	ERJ6ENF1102	M 11KOHM 1/10W
R7892	EVMEASA00B53	CONTROL 5KOHMB
R7901	ERJ6ENF6201	M 6.2KOHM 1/10W
R7903	ERJ6ENF1002	M 10KOHM 1/10W
R7904	ERD25V0R00	C 0 OHM 1/4W
R7905	ERD25V0R00	C 0 OHM 1/4W
R7906	ERD25V0R00	C 0 OHM 1/4W
R7907	ERJ6ENF7680	M 768 OHM 1/10W
R7908	ERJ6ENF2701	M 2.7KOHM 1/10W
R7914	ERJ6GEYJ103	M 10KOHM J 1/10W
R7915	ERJ6GEY0R00	M 0 OHM J 1/10W
R7916	ERJ6ENF6201	M 6.2KOHM 1/10W
R7918	ERJ6GEYJ102	M 1KOHM J 1/10W
R7919	ERJ6ENF6201	M 6.2KOHM 1/10W
R7919	ERJ6GEYJ102	M 1KOHM J 1/10W
R7920	ERJ6GEY0R00	M 0 OHM J 1/10W
R7921	ERJ6GEY0R00	M 0 OHM J 1/10W
R7924	ERJ6GEYJ103	M 10KOHM J 1/10W
R7925	ERJ6ENF4701	M 4.7KOHM 1/10W
R7926	ERJ6ENF4701	M 4.7KOHM 1/10W
R7927	ERJ6GEYJ102	M 1KOHM J 1/10W
R7928	ERJ6GEYJ102	M 1KOHM J 1/10W
R7929	ERJ6GEYJ102	M 1KOHM J 1/10W
R7930	ERJ6GEYJ471	M 470 OHM J 1/10W
R7931	ERJ6GEYJ471	M 470 OHM J 1/10W
R7932	ERJ6GEYJ471	M 470 OHM J 1/10W

Ref. No	Part No.	Description
R7934	ERD25V0R00	C 0 OHM 1/4W
R7935	ERD25V0R00	C 0 OHM 1/4W
R7937	ERJ6GEYJ471	M 470 OHM J 1/10W
R7938	ERJ6GEYJ471	M 470 OHM J 1/10W
R7941	ERJ6GEYJ471	M 470 OHM J 1/10W
R7942	ERJ6GEYJ333	M 33KOHM J 1/10W
R9601	ERJ6GEYJ562	M 5.6KOHM J 1/10W
R9602	ERJ6GEYJ562	M 5.6KOHM J 1/10W
R9603	ERJ6GEYJ562	M 5.6KOHM J 1/10W
R9604	ERJ6GEY0R00	M 0 OHM J 1/10W
R9605	ERJ6GEYJ331	M 330 OHM J 1/10W
R9606	ERJ6GEYJ183	M 18KOHM J 1/10W
R9607	ERJ6GEYJ562	M 5.6KOHM J 1/10W
R9608	ERJ6GEYJ471	M 470 OHM J 1/10W
R9609	ERJ6GEYJ181	M 180 OHM J 1/10W
R9610	ERJ6GEYJ181	M 180 OHM J 1/10W
R9611	ERDS2TJ561	C 560 OHM J 1/4W
R9612	ERJ6GEYJ471	M 470 OHM J 1/10W
R9613	ERJ6GEYJ222	M 2.2KOHM J 1/10W
R9614	ERJ6GEYJ271	M 270 OHM J 1/10W
R9615	ERJ6GEYJ102	M 1KOHM J 1/10W
R9616	ERJ6GEYJ471	M 470 OHM J 1/10W
R9617	ERJ6GEYJ122	M 1.2KOHM J 1/10W
R9618	ERJ6GEYJ153	M 15KOHM J 1/10W
R9619	ERJ6GEYJ101	M 100 OHM J 1/10W
R9620	ERJ6GEYJ101	M 100 OHM J 1/10W
R9622	ERJ6GEYJ393	M 39KOHM J 1/10W
R9623	ERJ6GEYJ153	M 15KOHM J 1/10W
R9624	ERJ6GEYJ334	M 330KOHM J 1/10W
R9625	ERJ6GEYJ222	M 2.2KOHM J 1/10W
R9626	ERJ6GEYJ331	M 330 OHM J 1/10W
R9627	ERJ6GEYJ102	M 1KOHM J 1/10W
R9628	ERJ6GEYJ472	M 4.7KOHM J 1/10W
R9629	ERJ6GEYJ471	M 470 OHM J 1/10W
R9630	ERJ6GEYJ271	M 270 OHM J 1/10W
R9631	ERJ6GEYJ101	M 100 OHM J 1/10W
R9632	ERJ6GEYJ101	M 100 OHM J 1/10W
R9634	ERJ6GEYJ103	M 10KOHM J 1/10W
R9635	ERJ6GEYJ101	M 100 OHM J 1/10W
R9636	ERJ6GEYJ101	M 100 OHM J 1/10W
R9637	ERJ6GEYJ101	M 100 OHM J 1/10W
R9638	ERJ6GEYJ101	M 100 OHM J 1/10W
R9639	ERJ6GEYJ101	M 100 OHM J 1/10W
R9640	ERJ6GEYJ101	M 100 OHM J 1/10W
R9641	ERJ6GEYJ101	M 100 OHM J 1/10W
R9642	ERJ6GEYJ102	M 1KOHM J 1/10W
R9643	ERJ6GEYJ102	M 1KOHM J 1/10W
R9644	ERJ6GEYJ102	M 1KOHM J 1/10W
R9645	ERJ6GEYJ102	M 1KOHM J 1/10W
R9646	ERJ6GEYJ821	M 820 OHM J 1/10W
R9647	ERJ6GEYJ101	M 100 OHM J 1/10W
R9648	ERJ6GEYJ121	M 120 OHM J 1/10W
R9649	ERJ6GEYJ121	M 120 OHM J 1/10W
R9650	ERJ6GEYJ101	M 100 OHM J 1/10W
R9651	ERJ6GEYJ101	M 100 OHM J 1/10W
R9652	ERJ6GEYJ101	M 100 OHM J 1/10W
R9653	ERJ6GEYJ101	M 100 OHM J 1/10W
R9655	ERJ6GEYJ104	M 100KOHM J 1/10W
R9657	ERJ6GEYJ750	M 75 OHM J 1/10W
R9658	ERJ6ENF2212	M 22.1KOHM 1/10W
R9663	ERJ6GEYJ100	M 10 OHM J 1/10W
R9664	ERJ6GEYJ102	M 1KOHM J 1/10W
R9665	ERJ6GEYJ471	M 470 OHM J 1/10W
R9666	ERJ6GEYJ272	M 2.7KOHM J 1/10W
R9668	ERJ6GEYJ911	M 910 OHM J 1/10W
R9674	ERJ6GEYJ273	M 27KOHM J 1/10W
R9675	ERJ6GEYJ562	M 5.6KOHM J 1/10W
R9676	ERJ6GEYJ103	M 10KOHM J 1/10W
R9677	ERJ6GEYJ273	M 27KOHM J 1/10W
R9678	ERJ6GEYJ562	M 5.6KOHM J 1/10W

Ref. No	Part No.	Description	Ref. No	Part No.	Description
R9679	ERJ6GEYJ103	M 10KOHM J 1/10W	C354	ECA2EM470	E 47UF 250V
R9680	ERJ6ENF5602	M 56KOHM 1/10W	C355	ECCF1H220JC	C 22PF J 50V
R9681	ERJ6GEYJ103	M 10KOHM J 1/10W	C356	ECKF1H103ZF	C 0.01UF Z 50V
R9682	ERJ6GEYJ103	M 10KOHM J 1/10W	C357	ECKF1H103ZF	C 0.01UF Z 50V
R9683	ERJ6GEYJ103	M 10KOHM J 1/10W	C358	ECQM4223JZ	P 0.022UF J 400V
R9685	ERJ6GEYJ103	M 10KOHM J 1/10W	C359	ECKD2H561KB2	C 560PF K 500V
R9686	ERJ6GEYJ102	M 1KOHM J 1/10W	C360	ECKD2H103PU	C 0.01UF P 500V
R9688	ERJ6ENF3162	M 31.6KOHM 1/10W	C361	ECKD3D102KBN	C 1000PF K 2KV
R9689	ERJ6GEYJ911	M 910 OHM J 1/10W	C365	ECA2EM470	E 47UF 250V
R9691	ERJ6GEYJ102	M 1KOHM J 1/10W	C366	ECA1CM221	E 220UF 16V
R9692	ERJ6GEYJ911	M 910 OHM J 1/10W	C367	ECA1HM4R7	E 4.7UF 50V
R9694	ERJ6GEYJ102	M 1KOHM J 1/10W	C368	ECA1VM470	E 47UF 35V
R9695	ERJ6GEYJ102	M 1KOHM J 1/10W	C370	ECA2EM470	E 47UF 250V
R9696	ERJ6GEYJ103	M 10KOHM J 1/10W	C372	ECKF1H103ZF	C 0.01UF Z 50V
R9697	ERJ6GEYJ103	M 10KOHM J 1/10W	C373	ECKF1H103ZF	C 0.01UF Z 50V
R9700	ERDS2TJ680	C 68 OHM J 1/4W	C374	ECCF1H150JC	C 15PF J 50V
R9701	ERDS2TJ680	C 68 OHM J 1/4W	C375	ECQM4223JZ	P 0.022UF J 400V
R9702	ERJ6GEYJ680	M 68 OHM J 1/10W	C376	ECKD2H103PU	C 0.01UF P 500V
R9703	ERJ6GEYJ103	M 10KOHM J 1/10W	C377	ECKD2H561KB2	C 560PF K 500V
R9704	ERJ6GEYJ103	M 10KOHM J 1/10W	C378	ECKD3D102KBN	C 1000PF K 2KV
R9705	ERJ6GEYJ562	M 5.6KOHM J 1/10W	C381	ECA1HM4R7	E 4.7UF 50V
R9706	ERJ6ENF2702	M 27KOHM 1/10W	C382	ECA1VM470	E 47UF 35V
CAPACITORS					
C002	ECA1HMR33	E 0.33UF 50V	C384	ECA2EM470	E 47UF 250V
C003	ECJ2VF1H104Z	C 0.1UF Z 50V	C386	ECCF1H220JC	C 22PF J 50V
C004	ECJ2VF1H104Z	C 0.1UF Z 50V	C387	ECKF1H103ZF	C 0.01UF Z 50V
C005	ECA1CM221	E 220UF 16V	C388	ECKF1H103ZF	C 0.01UF Z 50V
C006	ECJ2VF1H104Z	C 0.1UF Z 50V	C389	ECQM4223JZ	P 0.022UF J 400V
C007	ECJ2VF1H104Z	C 0.1UF Z 50V	C390	ECKD2H103PU	C 0.01UF P 500V
C008	ECUX1H561JCX	M 560PF J 50V	C391	ECKD2H561KB2	C 560PF K 500V
C009	ECA1CM221	E 220UF 16V	C392	ECKD3D102KBN	C 1000PF K 2KV
C010	ECA1HM4R7	E 4.7UF 50V	C400	ECA1VM102	E 1000UF 35V
C011	ECUX1H100DCX	C 10PF D 50V	C401	ECA1VM102	E 1000UF 35V
C012	ECUX1H100DCX	C 10PF D 50V	C402	ECA1HM010	E 1UF 50V
C013	ECA1VM470	E 47UF 35V	C407	ECA1VM102	E 1000UF 35V
C014	ECJ2VF1H104Z	C 0.1UF Z 50V	C408	ECQV1H105JM	P 1UF J 50V
C015	ECJ2VF1H104Z	C 0.1UF Z 50V	C409	ECQB1473KF	P 0.047UF K 100V
C017	ECUX1H100DCX	C 10PF D 50V	C411	ECA1HM100	E 10UF 50V
C018	ECJ2VF1H104Z	C 0.1UF Z 50V	C413	ECA1VM102	E 1000UF 35V
C019	ECJ2VF1H104Z	C 0.1UF Z 50V	C414	ECSF1EE225V	T 2.2UF 25V
C103	ECJ2VF1H104Z	C 0.1UF Z 50V	C416	EEANA1E1R0	E 1UF 25V
C104	ECJ2VF1H103Z	C 0.01UF Z 50V	C417	ECKF1H103ZF	C 0.01UF Z 50V
C107	ECJ2VF1H104Z	C 0.1UF Z 50V	C418	ECQV1H224JM	P 0.22UF J 50V
C108	ECJ2VF1H104Z	C 0.1UF Z 50V	C419	ECSF1EE475V	T 4.7UF 25V
C109	ECJ2XB1C184K	C 0.18PF K 16V	C420	ECA1HM470	E 47UF 50V
C110	ECJ2VF1H104Z	C 0.1UF Z 50V	C421	ECKF1H103ZF	C 0.01UF Z 50V
C111	ECJ2VF1H104Z	C 0.1UF Z 50V	C422	ECA1HM470	E 47UF 50V
C251	ECA1CM101	E 100UF 16V	C423	ECKF1H103ZF	C 0.01UF Z 50V
C252	ECUX1H222KBX	C 2200PF K 50V	C426	EEANA1E100	E 10UF 25V
C253	ECA1HM100	E 10UF 50V	C430	ECQB1224KF	P 0.22UF 100V
C255	ECA1EHG101	E 100UF 25V	C431	ECKF1H103ZF	C 0.01UF Z 50V
C256	ECUX1H222KBX	C 2200PF K 50V	C432	ECHS1H562JZ	P 5600PF J 50V
C257	ECA1HM100	E 10UF 50V	C441	ECKF1H103ZF	C 0.01UF Z 50V
C258	ECA1CM101	E 100UF 16V	C443	ECCF1H470JC	C 47PF J 50V
C260	ECA1VM102	E 1000UF 35V	C458	ECA1HM100	E 10UF 50V
C261	ECA1VM102	E 1000UF 35V	C459	ECKF1H103ZF	C 0.01UF Z 50V
C263	ECA1HMH4R7	E 4.7UF 50V	C470	ECQB1H102JF	P 1000PF J 50V
C264	ECA1HM222	E 2200UF 50V	C500	ECQB1H153JF	P 0.015UF J 50V
C266	ECA1HMH4R7	E 4.7UF 50V	C501	ECCF1H221JU	C 220PF J 50V
C267	ECQV1H224JM	P 0.22UF J 50V	C502	ECA1HM100	E 10UF 50V
C268	ECQV1H224JM	P 0.22UF J 50V	C503	ECQB1H272JF	P 2700PF J 50V
C269	ECA1HM470	E 47UF 50V	C504	ECA1CM101	E 100UF 16V
C270	ECQV1H224JM	P 0.22UF J 50V	C505	ECA1VM470	E 47UF 35V
C271	ECQV1H224JM	P 0.22UF J 50V	C506	ECKF1H103ZF	C 0.01UF Z 50V
C277	ECUX1H102JCX	C 1000PF J 50V	C507	ECA1HM220	E 22UF 50V
C278	ECUX1H102JCX	C 1000PF J 50V	C508	ECKF1H103ZF	C 0.01UF Z 50V
C351	ECA1HM4R7	E 4.7UF 50V	C509	ECA1VM101	E 100UF 35V
C352	ECA1VM470	E 47UF 35V	C510	ECQB1104JF	P 0.1UF J 100V
C354	ECA2EM470	E 47UF 250V	C511	ECA1VM101	E 100UF 35V
C355	ECCF1H220JC	C 22PF J 50V	C513	ECA1HM010	E 1UF 50V
C356	ECKF1H103ZF	C 0.01UF Z 50V	C514	ECQB1H222JF	P 2200PF J 50V
C357	ECKF1H103ZF	C 0.01UF Z 50V			
C358	ECQM4223JZ	P 0.022UF J 400V			
C359	ECKD2H561KB2	C 560PF K 500V			
C360	ECKD2H103PU	C 0.01UF P 500V			
C361	ECKD3D102KBN	C 1000PF K 2KV			
C365	ECA2EM470	E 47UF 250V			
C366	ECA1CM221	E 220UF 16V			
C367	ECA1HM4R7	E 4.7UF 50V			
C368	ECA1VM470	E 47UF 35V			
C370	ECA2EM470	E 47UF 250V			
C372	ECKF1H103ZF	C 0.01UF Z 50V			
C373	ECKF1H103ZF	C 0.01UF Z 50V			
C374	ECCF1H150JC	C 15PF J 50V			
C375	ECQM4223JZ	P 0.022UF J 400V			
C376	ECKD2H103PU	C 0.01UF P 500V			
C377	ECKD2H561KB2	C 560PF K 500V			
C378	ECKD3D102KBN	C 1000PF K 2KV			
C381	ECA1HM4R7	E 4.7UF 50V			
C382	ECA1VM470	E 47UF 35V			
C384	ECA2EM470	E 47UF 250V			
C386	ECCF1H220JC	C 22PF J 50V			
C387	ECKF1H103ZF	C 0.01UF Z 50V			
C388	ECKF1H103ZF	C 0.01UF Z 50V			
C389	ECQM4223JZ	P 0.022UF J 400V			
C390	ECKD2H103PU	C 0.01UF P 500V			
C391	ECKD2H561KB2	C 560PF K 500V			
C392	ECKD3D102KBN	C 1000PF K 2KV			
C400	ECA1VM102	E 1000UF 35V			
C401	ECA1VM102	E 1000UF 35V			
C402	ECA1HM010	E 1UF 50V			
C407	ECA1VM102	E 1000UF 35V			
C408	ECQV1H105JM	P 1UF J 50V			
C409	ECQB1473KF	P 0.047UF K 100V			
C411	ECA1HM100	E 10UF 50V			
C413	ECA1VM102	E 1000UF 35V			
C414	ECSF1EE225V	T 2.2UF 25V			
C416	EEANA1E1R0	E 1UF 25V			
C417	ECKF1H103ZF	C 0.01UF Z 50V			
C418	ECQV1H224JM	P 0.22UF J 50V			
C419	ECSF1EE475V	T 4.7UF 25V			
C420	ECA1HM470	E 47UF 50V			
C421	ECKF1H103ZF	C 0.01UF Z 50V			
C422	ECA1HM470	E 47UF 50V			
C423	ECKF1H103ZF	C 0.01UF Z 50V			
C426	EEANA1E100	E 10UF 25V			
C430	ECQB1224KF	P 0.22UF 100V			
C431	ECKF1H103ZF	C 0.01UF Z 50V			
C432	ECHS1H562JZ	P 5600PF J 50V			
C441	ECKF1H103ZF	C 0.01UF Z 50V			
C443	ECCF1H470JC	C 47PF J 50V			
C458	ECA1HM100	E 10UF 50V			
C459	ECKF1H103ZF	C 0.01UF Z 50V			
C470	ECQB1H102JF	P 1000PF J 50V			
C500	ECQB1H153JF	P 0.015UF J 50V			
C501	ECCF1H221JU	C 220PF J 50V			
C502	ECA1HM100	E 10UF 50V			
C503	ECQB1H272JF	P 2700PF J 50V			
C504	ECA1CM101	E 100UF 16V			
C505	ECA1VM470	E 47UF 35V			
C506	ECKF1H103ZF	C 0.01UF Z 50V			
C507	ECA1HM220	E 22UF 50V			
C508	ECKF1H103ZF	C 0.01UF Z 50V			
C509	ECA1VM101	E 100UF 35V			
C510	ECQB1104JF	P 0.1UF J 100V			
C511	ECA1VM101	E 100UF 35V			
C513	ECA1HM010	E 1UF 50V			
C514	ECQB1H222JF	P 2200PF J 50V			

Ref. No	Part No.	Description			
C515	ECA1CM471	E	470UF	16V	
C516	ECA1CM101	E	100UF	16V	
C518	ECA1VM101	E	100UF	35V	
C519	ECA1CM101	E	100UF	16V	
C520	ECQB1H223JF	P	0.022UF	J	50V
C521	ECA1HM471	E	470UF	50V	
C522	ECA1HM100	E	10UF	50V	
C523	ECA1HM100	E	10UF	50V	
C548	ECQB1H222JF	P	2200PF	J	50V
C551	ECA1VM101	E	100UF	35V	
C552	ECKD3D681KBN	C	680PF	K	2KV
C553	ECQB1H183JF	P	0.018UF	J	50V
C554	ECKD3D681KBN	C	680PF	K	2KV
C555	ECA0JM471	E	470UF	6.3V	
C556	EEANA1E4R7	E	4.7UF	25V	
C558	ECA160V33U	E	33UF	160V	
C562	ECKD3D101KBN	C	100PF	K	2KV
C565	ECWH12H332JS	P	3300PF	J	1.2KV
C566	ECQB1183JF	P	0.018UF	J	100V
C567	ECWH12H332JS	P	3300PF	J	1.2KV
C568	ECWH12H332JS	P	3300PF	J	1.2KV
C569	ECWH12H222JS	P	2200PF	J	1.2KV
C574	ECA160V33U	E	33UF	160V	
C576	ECQB1224JF	P	0.22UF	J	100V
C583	ECA1CM101	E	100UF	16V	
C584	ECKD3D101JBN	C	100PF	J	2KV
C585	ECQB1H473JF	P	0.047UF	J	50V
C590	ECA160V33U	E	33UF	160V	
C591	ECQV1H105JM	P	1UF	J	50V
C593	ECKD3D221KBN	C	220PF	K	2KV
C594	ECKD3D221KBN	C	220PF	K	2KV
C595	ECKD3D391KBN	C	390PF	K	2KV
C596	ECKD3D221KBN	C	220PF	K	2KV
C610	ECA1VMH470	E	47UF	35V	
C611	ECQB1H103JF	P	0.01UF	J	50V
C612	EEANA1E100	E	10UF	25V	
C613	ECA1HM470	E	47UF	50V	
C614	ECKF1H102KB	C	1000PF	K	50V
C643	ECUX1H102KBX	C	1000PF	K	50V
C700	ECEA1CN101U	E	100UF	16V	
C701	ECA1CM101	E	100UF	16V	
C702	ECQB1H333JF	P	0.033UF	J	50V
C703	ECA1CM101	E	100UF	16V	
C704	ECKF1H151KB	C	150PF	K	50V
C705	ECEA1HN010U	E	1UF	50V	
C706	ECQB1H104JF	P	0.1UF	J	50V
C707	ECA1HM010	E	1UF	50V	
C708	ECKF1H102KB	C	1000PF	K	50V
C709	ECQB1H104JF	P	0.1UF	J	50V
C710	ECQB1H104JF	P	0.1UF	J	50V
C711	ECQB1H104JF	P	0.1UF	J	50V
C712	ECEA1CN100U	E	10UF	16V	
C713	ECQB1H153JF	P	0.015UF	J	50V
C714	ECA1CM101	E	100UF	16V	
C715	ECQE12473KF	P	0.047UF	K	1.2KV
C717	ECQB1H332JF	P	3300PF	J	50V
C718	ECKF1H102KB	C	1000PF	K	50V
C719	ECQB1H104JF	P	0.1UF	J	50V
C720	ECQB1H104JF	P	0.1UF	J	50V
C721	ECA1HM010	E	1UF	50V	
C722	ECEA1CN100U	E	10UF	16V	
C723	ECEA1CN470U	E	47UF	16V	
C751	ECWH15H332JN	P	3300PF	J	1.5KV
C753	ECWH15H272JN	P	2700PF	J	1.5KV
C797	ECWF2274JBB	P	0.27UF	250V	
C798	ECWF2274JBB	P	0.27UF	250V	
C801	ECKDAE472ZE	C	4700PF	Z	
C802	ECKDAE472ZE	C	4700PF	Z	
C803	ECKDAE472ZE	C	4700PF	Z	
C804	ECKDAE472ZE	C	4700PF	Z	

Ref. No	Part No.	Description			
C808	ECQV1H823JM	P	0.082UF	J	50V
C811	ECQB1H681JF	P	680PF	J	50V
C812	ECA1HM2R2	E	2.2UF		50V
C813	ECQB1H473JF	P	0.047UF	J	50V
C814	ECQV1H334JM	P	0.33UF	J	50V
C815	ECQB1H103JF	P	0.01UF	J	50V
C816	ECQB1H222JF	P	2200PF	J	50V
C817	ECKF1H103ZF	C	0.01UF	Z	50V
C818	ECQB1H472JF	P	4700PF	J	50V
C819	ECQV1H104JM	P	0.1UF	J	50V
C820	EEUFC1V151	E	150UF		35V
C821	ECCF1H101JC	C	100PF	J	50V
C823	ECKD3D222KBP	C	2200PF	K	2KV
C826	ECKD3D102KBP	C	1000PF	K	2KV
C828	ECQM4153KZ	P	0.015UF	K	400V
C829	EC0S2GP221BB	E	220UF		400V
C830	EC0S2GP221BB	E	220UF		400V
C831	ECKCWS471MBB	C	470PF	M	
C833	ECQB1H332JF	P	3300PF	J	50V
C835	ECQB1H473JF	P	0.047UF	J	50V
C840	ECA1HM221	E	220UF		50V
C841	EEUFC1H102	E	1000UF		50V
C842	ECKD2H471KB2	C	470PF	K	500V
C843	ECKD2H471KB2	C	470PF	K	500V
C846	ECKD3D101KBP	C	100PF	K	2KV
C847	ECKD3A471KBP	C	470PF	K	1KV
C848	ECKD3A331KBP	C	330PF	K	1KV
C849	ECKD3A331KBP	C	330PF	K	1KV
C850	ECKD2H471KB2	C	470PF	K	500V
C851	ECKD3D821KBP	C	820PF	K	2KV
C852	ECKD2H471KB2	C	470PF	K	500V
C855	EEUFC1E332	E	3300UF		25V
C856	ECA1EHG102	E	1000UF		25V
C857	ECA1VHG102	E	1000UF		35V
C858	EC0S2CB471BB	E	470UF		160V
C859	EEUFC1E272	E	2700UF		25V
C860	EEUFC1C152	E	1500UF		16V
C861	ECA2VHG330	E	33UF		350V
C862	ECKF1H103ZF	C	0.01UF	Z	50V
C863	ECA1VM101	E	100UF		35V
C864	ECA1CM471	E	470UF		16V
C865	ECKF1H103ZF	C	0.01UF	Z	50V
C866	ECA1HM100	E	10UF		50V
C867	ECA1CM101	E	100UF		16V
C868	ECQM2103KZ	P	0.01UF	K	200V
C869	ECA0JM331	E	330UF		6.3V
C870	EEANA1E100	E	10UF		25V
C871	EEANA1E100	E	10UF		25V
C873	ECA2EHG220	E	22UF		250V
C874	ECQM4103KZ	P	0.01UF	K	400V
C875	ECA1CHG470	E	47UF		16V
C876	ECA1CHG470	E	47UF		16V
C877	ECA1HHG2R2	E	2.2UF		50V
C901	ECEA1CN100U	E	10UF		16V
C902	ECA1CM101	E	100UF		16V
C906	ECA1CM101	E	100UF		16V
C907	ECCF1H121JC	C	120PF	J	50V
C910	ECA1HM100	E	10UF		50V
C911	ECA1CM101	E	100UF		16V
C920	ECKF1H103ZF	C	0.01UF	Z	50V
C932	ECA1HM101	E	100UF		50V
C952	ECA1HM101	E	100UF		50V
C955	ECQM2103KZ	P	0.01UF	K	200V
C958	ECA2CM100	E	10UF		160V
C961	ECA2CM100	E	10UF		160V
C962	ECKF1H103ZF	C	0.01UF	Z	50V
C964	ECA1CM101	E	100UF		16V
C966	ECA1CM101	E	100UF		16V
C967	ECA1CM221	E	220UF		16V
C972	ECKF1H103ZF	C	0.01UF	Z	50V

Ref. No	Part No.	Description			
C1589	ECJ2VF1H104Z	C	0.1UF	Z	50V
C1590	ECJ2VF1H104Z	C	0.1UF	Z	50V
C1591	ECJ2VF1H104Z	C	0.1UF	Z	50V
C1592	ECA1CM221	E	220UF		16V
C1593	ECA1CM221	E	220UF		16V
C1594	ECJ2VF1H104Z	C	0.1UF	Z	50V
C1595	ECJ2VF1H104Z	C	0.1UF	Z	50V
C1596	ECJ2VF1H104Z	C	0.1UF	Z	50V
C1597	ECJ2VF1H104Z	C	0.1UF	Z	50V
C1598	ECJ2VF1H104Z	C	0.1UF	Z	50V
C1599	ECJ2VF1H104Z	C	0.1UF	Z	50V
C1600	ECJ2VF1H104Z	C	0.1UF	Z	50V
C1601	ECJ2VF1H104Z	C	0.1UF	Z	50V
C1602	ECJ2VF1H104Z	C	0.1UF	Z	50V
C1603	ECJ2VF1H104Z	C	0.1UF	Z	50V
C1604	ECJ2VF1H104Z	C	0.1UF	Z	50V
C1605	ECJ2VF1H104Z	C	0.1UF	Z	50V
C1606	ECJ2VF1H104Z	C	0.1UF	Z	50V
C1607	ECJ2VF1H104Z	C	0.1UF	Z	50V
C1608	ECJ2VF1H104Z	C	0.1UF	Z	50V
C1609	ECJ2VF1H104Z	C	0.1UF	Z	50V
C1610	ECJ2VF1H104Z	C	0.1UF	Z	50V
C1611	ECA1CM471	E	470UF		16V
C1612	ECJ2VF1H104Z	C	0.1UF	Z	50V
C1614	ECJ2VF1H104Z	C	0.1UF	Z	50V
C1615	ECJ2VF1H104Z	C	0.1UF	Z	50V
C1616	ECJ2VF1H104Z	C	0.1UF	Z	50V
C1617	ECJ2VF1H104Z	C	0.1UF	Z	50V
C1618	ECJ2VF1H104Z	C	0.1UF	Z	50V
C1619	ECJ2VF1H104Z	C	0.1UF	Z	50V
C1620	ECJ2VF1H104Z	C	0.1UF	Z	50V
C1621	ECJ2VF1H104Z	C	0.1UF	Z	50V
C1622	ECJ2VF1H104Z	C	0.1UF	Z	50V
C1623	ECJ2VF1H104Z	C	0.1UF	Z	50V
C1624	ECJ2VF1H104Z	C	0.1UF	Z	50V
C1625	ECJ2VF1H104Z	C	0.1UF	Z	50V
C1626	ECJ2VF1H104Z	C	0.1UF	Z	50V
C1627	ECJ2VF1H104Z	C	0.1UF	Z	50V
C1628	ECJ2VF1H104Z	C	0.1UF	Z	50V
C1629	ECJ2VF1H104Z	C	0.1UF	Z	50V
C1630	ECJ2VF1H104Z	C	0.1UF	Z	50V
C1631	ECJ2VF1H104Z	C	0.1UF	Z	50V
C1632	ECJ2VF1H104Z	C	0.1UF	Z	50V
C1633	ECJ2VF1H104Z	C	0.1UF	Z	50V
C1636	ECJ2VF1H104Z	C	0.1UF	Z	50V
C1637	ECJ2VF1H104Z	C	0.1UF	Z	50V
C1638	ECJ2VF1H104Z	C	0.1UF	Z	50V
C1639	ECJ2VF1H104Z	C	0.1UF	Z	50V
C1642	ECJ2VF1H104Z	C	0.1UF	Z	50V
C1643	ECJ2VF1H104Z	C	0.1UF	Z	50V
C1644	ECJ2VF1H104Z	C	0.1UF	Z	50V
C1645	ECJ2VF1H104Z	C	0.1UF	Z	50V
C1647	ECUX1H470JCX	C	47PF	J	50V
C1648	ECJ2VF1H104Z	C	0.1UF	Z	50V
C1649	ECA1CM101	E	100UF		16V
C1650	ECJ2VF1H104Z	C	0.1UF	Z	50V
C1651	ECJ2VF1H104Z	C	0.1UF	Z	50V
C1652	ECA1CM101	E	100UF		16V
C1653	ECJ2VF1H104Z	C	0.1UF	Z	50V
C1654	ECJ2VF1H104Z	C	0.1UF	Z	50V
C1655	ECA1VM470	E	47UF		35V
C1656	ECJ2VF1H104Z	C	0.1UF	Z	50V
C1658	ECJ2VF1H104Z	C	0.1UF	Z	50V
C1659	ECA1VM470	E	47UF		35V
C1660	ECJ2VF1H104Z	C	0.1UF	Z	50V
C1661	ECA1CM101	E	100UF		16V
C1662	ECJ2VF1H104Z	C	0.1UF	Z	50V
C1663	ECUX1H150JCX	C	15PF	J	50V
C1664	ECJ2VF1H104Z	C	0.1UF	Z	50V
C1666	ECUX1H390JCX	C	39PF	J	50V

Ref. No	Part No.	Description			
C1667	ECUX1H820JCX	C	82PF	J	50V
C1668	ECUX1H680JCX	C	68PF	J	50V
C1669	ECUX1H271JCX	C	270PF	J	50V
C1670	ECUX1H391JCX	C	390PF	J	50V
C1671	ECUX1H390JCX	C	39PF	J	50V
C1672	ECUX1H820JCX	C	82PF	J	50V
C1673	ECUX1H680JCX	C	68PF	J	50V
C1674	ECUX1H271JCX	C	270PF	J	50V
C1675	ECUX1H391JCX	C	390PF	J	50V
C1676	ECUX1H390JCX	C	39PF	J	50V
C1677	ECUX1H820JCX	C	82PF	J	50V
C1678	ECUX1H680JCX	C	68PF	J	50V
C1679	ECUX1H271JCX	C	270PF	J	50V
C1680	ECUX1H391JCX	C	390PF	J	50V
C1681	ECUX1H820JCX	C	82PF	J	50V
C1682	ECJ2VF1H104Z	C	0.1UF	Z	50V
C1683	ECUX1H101JCX	C	100PF	J	50V
C1685	ECJ2VF1H104Z	C	0.1UF	Z	50V
C1686	ECUX1H101JCX	C	100PF	J	50V
C1688	ECJ2VF1H104Z	C	0.1UF	Z	50V
C1689	ECJ2VF1H104Z	C	0.1UF	Z	50V
C1690	ECJ2VF1C105Z	C	1UF	Z	16V
C1691	ECJ2VF1C105Z	C	1UF	Z	16V
C1692	EEUNA1E220	E	22UF		25V
C1693	ECA1CM101	E	100UF		16V
C1695	ECUX1H101JCX	C	100PF	J	50V
C1696	EEUNA1E220	E	22UF		25V
C1697	EEUNA1E220	E	22UF		25V
C1698	EEUNA1E220	E	22UF		25V
C1801	ECA1CM101	E	100UF		16V
C1802	ECA1CM101	E	100UF		16V
C1803	ECJ2VF1H104Z	C	0.1UF	Z	50V
C1804	ECJ2VF1H104Z	C	0.1UF	Z	50V
C1805	ECUX1H150JCX	C	15PF	J	50V
C1806	ECUX1H180JCX	C	18PF	J	50V
C1807	ECJ2VF1H104Z	C	0.1UF	Z	50V
C1808	ECJ2VF1H104Z	C	0.1UF	Z	50V
C1809	ECJ2VF1H104Z	C	0.1UF	Z	50V
C1810	ECA1CM101	E	100UF		16V
C1811	ECUX1H220JCX	C	22PF	J	50V
C1812	ECJ2VB1C104K	C	0.1UF	K	16V
C1813	ECJ2VF1H104Z	C	0.1UF	Z	50V
C1814	ECUX1H040CCX	C	4PF	C	50V
C1815	ECUX1H220JCX	C	22PF	J	50V
C1816	ECJ2VF1H104Z	C	0.1UF	Z	50V
C1817	ECUX1H331JCX	C	330PF	J	50V
C1818	ECJ2VB1C104K	C	0.1UF	K	16V
C1819	ECA1CM101	E	100UF		16V
C1820	ECUX1H680JCX	C	68PF	J	50V
C1821	ECJ2VF1H104Z	C	0.1UF	Z	50V
C1823	ECUX1H331JCX	C	330PF	J	50V
C1824	ECJ2VF1H104Z	C	0.1UF	Z	50V
C1825	ECJ2VB1C104K	C	0.1UF	K	16V
C1826	ECJ2VB1C104K	C	0.1UF	K	16V
C1827	ECJ2VB1C104K	C	0.1UF	K	16V
C1828	ECUX1H150JCX	C	15PF	J	50V
C1829	ECJ2VB1C104K	C	0.1UF	K	16V
C1830	ECJ2VB1C104K	C	0.1UF	K	16V
C1831	ECJ2VB1C104K	C	0.1UF	K	16V
C1832	ECJ2VF1H104Z	C	0.1UF	Z	50V
C1833	ECUX1H180JCX	C	18PF	J	50V
C1834	ECJ2VF1H104Z	C	0.1UF	Z	50V
C1835	ECJ2VB1C104K	C	0.1UF	K	16V
C1836	ECUX1H332KBX	C	3300PF	K	50V
C1837	ECJ2VB1C104K	C	0.1UF	K	16V
C1838	ECJ2VB1C104K	C	0.1UF	K	16V
C1840	ECUX1H332KBX	C	3300PF	K	50V
C1842	ECA1CM101	E	100UF		16V
C1843	ECJ2VF1H104Z	C	0.1UF	Z	50V
C1847	ECUX1H331JCX	C	330PF	J	50V

Ref. No	Part No.	Description						
C1848	ECUX1H102KBX	C	1000PF	K	50V			
C1849	ECUX1H102KBX	C	1000PF	K	50V			
C2103	ECUX1H391KBX	C	390PF	K	50V			
C2104	ECUX1H102KBX	C	1000PF	K	50V			
C2105	ECUX1H102KBX	C	1000PF	K	50V			
C2106	ECUX1H102KBX	C	1000PF	K	50V			
C2107	ECUX1H102KBX	C	1000PF	K	50V			
C2108	ECUX1H102KBX	C	1000PF	K	50V			
C2110	ECUX1H102KBX	C	1000PF	K	50V			
C2111	ECA1HM100	E	10UF		50V			
C2112	ECJ2VF1H104Z	C	0.1UF	Z	50V			
C2113	ECA1HM100	E	10UF		50V			
C2114	ECA1CM101	E	100UF		16V			
C2115	ECJ2VF1H104Z	C	0.1UF	Z	50V			
C2116	ECUX1H102KBX	C	1000PF	K	50V			
C2117	ECUX1H471KBX	C	470PF	K	50V			
C2118	ECA1HM3R3	E	3.3UF		50V			
C2119	ECUX1H471KBX	C	470PF	K	50V			
C2120	ECJ2VF1H104Z	C	0.1UF	Z	50V			
C2121	ECUX1H221JCX	C	220PF	J	50V			
C2122	ECUX1H221JCX	C	220PF	J	50V			
C2123	ECUX1H221JCX	C	220PF	J	50V			
C2124	ECJ2VF1H104Z	C	0.1UF	Z	50V			
C2125	ECA1HM100	E	10UF		50V			
C2126	ECUX1H221JCX	C	220PF	J	50V			
C2127	ECJ2VF1H104Z	C	0.1UF	Z	50V			
C2128	ECUX1H221JCX	C	220PF	J	50V			
C2129	ECA1HM100	E	10UF		50V			
C2130	ECUX1H221JCX	C	220PF	J	50V			
C2131	ECQV1H334JM	P	0.33UF	J	50V			
C2132	ECA1HM100	E	10UF		50V			
C2133	ECUX1H470JCX	C	47PF	J	50V			
C2134	ECUX1H470JCX	C	47PF	J	50V			
C2135	ECUX1H070DCX	C	7PF	D	50V			
C2137	ECJ2VF1H104Z	C	0.1UF	Z	50V			
C2138	ECUX1H010CCX	C	1PF	C	50V			
C2139	ECUX1H010CCX	C	1PF	C	50V			
C2141	ECUX1H560JCX	C	56PF	J	50V			
C2142	ECA1HM100	E	10UF		50V			
C2144	ECUX1H560JCX	C	56PF	J	50V			
C2146	ECA1HM100	E	10UF		50V			
C2147	ECUX1H103KBX	C	0.01UF	K	50V			
C2148	ECUX1H103KBX	C	0.01UF	K	50V			
C2301	ECA1VM470	E	47UF		35V			
C2302	ECA1VM470	E	47UF		35V			
C2353	ECA1CM471	E	470UF		16V			
C2356	ECA1HM4R7	E	4.7UF		50V			
C2359	ECA1HM4R7	E	4.7UF		50V			
C2361	ECA1VM470	E	47UF		35V			
C2362	ECA1CM101	E	100UF		16V			
C2363	ECA1HM221	E	220UF		50V			
C2364	ECA1HM221	E	220UF		50V			
C2365	ECA1CM101	E	100UF		16V			
C2366	ECA0JM222	E	2200UF		6.3V			
C2367	ECJ2VF1H104Z	C	0.1UF	Z	50V			
C2370	ECA1HM100	E	10UF		50V			
C2371	ECUX1H472KBX	C	4700PF	K	50V			
C2372	ECUX1H472KBX	C	4700PF	K	50V			
C2375	ECJ2VF1C104Z	C	0.1UF	Z	16V			
C2376	ECA1HM010	E	1UF		50V			
C2381	ECKF1H102KB	C	1000PF	K	50V			
C2382	ECKF1H102KB	C	1000PF	K	50V			
C2401	ECUX1H102KBX	C	1000PF	K	50V			
C2402	ECUX1H102KBX	C	1000PF	K	50V			
C2403	ECUX1H332KBX	C	3300PF	K	50V			
C2404	ECUX1H332KBX	C	3300PF	K	50V			
C2408	ECEA1CKA100	E	10UF		16V			
C2410	ECA1EM471	E	470UF		25V			
C2412	ECEA1HKN010	E	1UF		50V			
C2413	ECEA1CKA101	E	100UF		16V			
C2414	ECUX1H150JCX	C	15PF	J	50V			
C2415	ECUX1H150JCX	C	15PF	J	50V			
C2416	EEANA1E1R0	E	1UF		25V			
C2417	EEANA1E1R0	E	1UF		25V			
C2418	EEANA1E1R0	E	1UF		25V			
C2419	EEANA1E1R0	E	1UF		25V			
C2420	ECUX1H150JCX	C	15PF	J	50V			
C2421	ECUX1H150JCX	C	15PF	J	50V			
C2422	ECUX1H561JCX	M	560PF	J	50V			
C2423	ECUX1H561JCX	M	560PF	J	50V			
C2424	ECUX1H561JCX	M	560PF	J	50V			
C2425	ECUX1H561JCX	M	560PF	J	50V			
C2427	ECUX1H561JCX	M	560PF	J	50V			
C2428	ECUX1H561JCX	M	560PF	J	50V			
C2430	ECUX1H561JCX	M	560PF	J	50V			
C2431	ECUX1H561JCX	M	560PF	J	50V			
C2432	ECEA1HKA010	E	1UF		50V			
C2433	ECEA1HKA010	E	1UF		50V			
C2434	ECEA1HKA010	E	1UF		50V			
C2435	ECEA1HKA010	E	1UF		50V			
C2436	ECEA1HKA010	E	1UF		50V			
C2437	ECUX1H561JCX	M	560PF	J	50V			
C2438	ECUX1H561JCX	M	560PF	J	50V			
C2439	ECEA1HKA010	E	1UF		50V			
C2440	ECUX1H222KBX	C	2200PF	K	50V			
C2441	ECUX1H222KBX	C	2200PF	K	50V			
C2442	ECUX1H222KBX	C	2200PF	K	50V			
C2443	ECUX1H222KBX	C	2200PF	K	50V			
C2444	ECUX1H222KBX	C	2200PF	K	50V			
C2445	ECUX1H222KBX	C	2200PF	K	50V			
C2446	ECUX1H561JCX	M	560PF	J	50V			
C2447	ECUX1H561JCX	M	560PF	J	50V			
C2448	ECEA1HKN010	E	1UF		50V			
C2449	ECEA1HKN010	E	1UF		50V			
C2450	ECUX1H150JCX	C	15PF	J	50V			
C2451	ECUX1H561JCX	M	560PF	J	50V			
C2452	ECJ2VF1H103Z	C	0.01UF	Z	50V			
C2463	ECUX1H102KBX	C	1000PF	K	50V			
C2464	ECUX1H102KBX	C	1000PF	K	50V			
C2501	ECA1CM101	E	100UF		16V			
C2502	ECA1HM010	E	1UF		50V			
C2503	ECA1HM010	E	1UF		50V			
C2504	ECUX1H010CCX	C	1PF	C	50V			
C2505	ECJ2VF1H104Z	C	0.1UF	Z	50V			
C2506	ECA1HM3R3	E	3.3UF		50V			
C2507	ECA1HM100	E	10UF		50V			
C2508	ECA1HM100	E	10UF		50V			
C2509	ECUX1H010CCX	C	1PF	C	50V			
C2510	ECJ2VF1H104Z	C	0.1UF	Z	50V			
C2511	ECJ2VF1H104Z	C	0.1UF	Z	50V			
C2513	ECJ2VF1H104Z	C	0.1UF	Z	50V			
C2514	ECUX1H102KBX	C	1000PF	K	50V			
C2515	ECJ2VF1H104Z	C	0.1UF	Z	50V			
C2517	ECUX1H102KBX	C	1000PF	K	50V			
C2518	ECA1HM010	E	1UF		50V			
C2520	ECJ2XF1C334Z	C	0.33UF	Z	16V			
C2521	ECJ2XF1C334Z	C	0.33UF	Z	16V			
C2522	ECJ2XF1C334Z	C	0.33UF	Z	16V			
C2523	ECJ2XF1C334Z	C	0.33UF	Z	16V			
C2524	ECJ2XF1C334Z	C	0.33UF	Z	16V			
C2525	ECUX1H102KBX	C	1000PF	K	50V			
C2526	ECA1HM100	E	10UF		50V			
C2527	ECJ2XF1C334Z	C	0.33UF	Z	16V			
C2528	ECJ2XF1C334Z	C	0.33UF	Z	16V			
C2532	ECA1VM102	E	1000UF		35V			
C2542	ECA1VM102	E	1000UF		35V			
C2552	EC0S2GA101BB	E	100UF		400V			
C2553	ECA1CM221	E	220UF		16V			
C2554	ECQV1H104JM	P	0.1UF	J	50V			
C2555	ECKD3D102KBR	C	1000PF	K	2KV			

Ref. No	Part No.	Description		
C2556	ECA1CM221	E	220UF	16V
C2557	ECQB1H333JF	P	0.033UF J	50V
C2558	ECQB1H683JF	P	0.068UF J	50V
C2559	ECKD2H103KB2	C	0.01UF K	500V
C2569	ECKD2H681KB2	C	680PF K	500V
C2572	EEUFC1E331	E	330UF	25V
C2573	ECA1HHG102	E	1000UF	50V
C2599	ECUX1H103KBX	C	0.01UF K	50V
C2610	ECA1HM010	E	1UF	50V
C2612	ECUX1H223KBX	C	0.022UF K	50V
C2615	ECA1HM010	E	1UF	50V
C2618	ECEA1HN010U	E	1UF	50V
C2619	ECEA1HN010U	E	1UF	50V
C2623	ECQV1H474JM	P	0.47UF J	50V
C2624	ECQV1H474JM	P	0.47UF J	50V
C2625	ECQV1H474JM	P	0.47UF J	50V
C2626	ECQV1H474JM	P	0.47UF J	50V
C2628	ECEA1HN010U	E	1UF	50V
C2629	ECEA1HN010U	E	1UF	50V
C2631	ECUX1H101JCX	C	100PF J	50V
C2632	ECA1HM330	E	33UF	50V
C2633	ECJ2VF1H103Z	C	0.01UF Z	50V
C2634	ECA1HM010	E	1UF	50V
C2635	ECUX1H222KBX	C	2200PF K	50V
C2636	ECA1HM010	E	1UF	50V
C2637	ECJ2VF1H103Z	C	0.01UF Z	50V
C2638	ECQV1H474JM	P	0.47UF J	50V
C2639	ECUX1H102KBX	C	1000PF K	50V
C2641	ECUX1H101JCX	C	100PF J	50V
C2642	ECA1HM330	E	33UF	50V
C2643	ECJ2VF1H103Z	C	0.01UF Z	50V
C2644	ECA1HM010	E	1UF	50V
C2645	ECUX1H222KBX	C	2200PF K	50V
C2646	ECA1HM010	E	1UF	50V
C2647	ECJ2VF1H103Z	C	0.01UF Z	50V
C2648	ECQV1H474JM	P	0.47UF J	50V
C2649	ECUX1H102KBX	C	1000PF K	50V
C2651	ECUX1H101JCX	C	100PF J	50V
C2652	ECA1HM330	E	33UF	50V
C2653	ECJ2VF1H103Z	C	0.01UF Z	50V
C2654	ECA1HM010	E	1UF	50V
C2655	ECUX1H222KBX	C	2200PF K	50V
C2656	ECA1HM010	E	1UF	50V
C2657	ECJ2VF1H103Z	C	0.01UF Z	50V
C2658	ECQV1H474JM	P	0.47UF J	50V
C2661	ECUX1H101JCX	C	100PF J	50V
C2662	ECA1HM330	E	33UF	50V
C2663	ECJ2VF1H103Z	C	0.01UF Z	50V
C2664	ECA1HM010	E	1UF	50V
C2665	ECUX1H222KBX	C	2200PF K	50V
C2666	ECA1HM010	E	1UF	50V
C2667	ECJ2VF1H103Z	C	0.01UF Z	50V
C2668	ECQV1H474JM	P	0.47UF J	50V
C2683	ECUX1H561JCX	M	560PF J	50V
C2684	ECUX1H561JCX	M	560PF J	50V
C2685	ECUX1H561JCX	M	560PF J	50V
C2686	ECUX1H561JCX	M	560PF J	50V
C3001	ECJ2VF1H103Z	C	0.01UF Z	50V
C3002	ECA1VM470	E	47UF	35V
C3003	ECUX1H102ZFX	C	1000PF Z	50V
C3004	ECJ2VF1H104Z	C	0.1UF Z	50V
C3005	ECJ2VF1H104Z	C	0.1UF Z	50V
C3006	ECA1HM4R7	E	4.7UF	50V
C3007	ECA1HM4R7	E	4.7UF	50V
C3008	ECJ2VF1H104Z	C	0.1UF Z	50V
C3009	ECJ2VF1H473Z	C	0.047UF Z	50V
C3010	ECUX1H680JCX	C	68PF J	50V
C3011	ECA1VM470	E	47UF	35V
C3012	ECA1VM470	E	47UF	35V
C3013	ECA1VM470	E	47UF	35V

Ref. No	Part No.	Description		
C3014	EEUNA1A470	E	47UF	10V
C3015	ECJ2VF1H104Z	C	0.1UF Z	50V
C3016	ECA1VM470	E	47UF	35V
C3017	ECJ2VF1H104Z	C	0.1UF Z	50V
C3018	ECJ2VF1H104Z	C	0.1UF Z	50V
C3019	ECJ2VF1H104Z	C	0.1UF Z	50V
C3020	ECJ2VF1H104Z	C	0.1UF Z	50V
C3021	ECA1CM221	E	220UF	16V
C3022	ECA1CM101	E	100UF	16V
C3023	ECA1HM100	E	10UF	50V
C3024	ECA1HM2R2	E	2.2UF	50V
C3025	EEUNA1A470	E	47UF	10V
C3027	ECJ2VF1H104Z	C	0.1UF Z	50V
C3028	ECA1CHG471	E	470UF	16V
C3029	ECA1CHG471	E	470UF	16V
C3030	ECA1VM101	E	100UF	35V
C3031	ECA1VM101	E	100UF	35V
C3032	ECA1EHG101	E	100UF	25V
C3033	ECKF1H103ZF	C	0.01UF Z	50V
C3034	ECKF1H103ZF	C	0.01UF Z	50V
C3035	ECKF1H103ZF	C	0.01UF Z	50V
C3036	ECKF1H103ZF	C	0.01UF Z	50V
C3037	ECKF1H103ZF	C	0.01UF Z	50V
C3038	ECKF1H103ZF	C	0.01UF Z	50V
C3039	ECA1CM101	E	100UF	16V
C3040	ECA1CM221	E	220UF	16V
C3041	ECKF1H103ZF	C	0.01UF Z	50V
C3048	ECA1CHG221	E	220UF	16V
C3049	ECUX1H470JCX	C	47PF J	50V
C3050	ECA1CM471	E	470UF	16V
C3051	ECA1CHG101	E	100UF	50V
C3088	ECKF1H103ZF	C	0.01UF Z	50V
C3120	ECUX1H103KBX	C	0.01UF K	50V
C3122	ECUX1H102KBX	C	1000PF K	50V
C3123	ECUX1H103KBX	C	0.01UF K	50V
C3124	ECUX1H102KBX	C	1000PF K	50V
C3255	ECA1HM4R7	E	4.7UF	50V
C3256	ECA1HM4R7	E	4.7UF	50V
C3281	ECKF1H561KB	C	560PF K	50V
C3283	ECKF1H561KB	C	560PF K	50V
C3351	ECKF1H181KB	C	180PF K	50V
C3352	ECA1HM220	E	22UF	50V
C3353	ECKF1H103KB	C	0.01UF K	50V
C3361	ECKF1H181KB	C	180PF K	50V
C3362	ECA1HM220	E	22UF	50V
C3363	ECKF1H103KB	C	0.01UF K	50V
C3371	ECKF1H181KB	C	180PF K	50V
C3372	ECA1HM220	E	22UF	50V
C3373	ECKF1H103KB	C	0.01UF K	50V
C3401	ECEA1HKA100	E	10UF	50V
C3402	ECUX1H561JCX	M	560PF J	50V
C3403	ECUX1H561JCX	M	560PF J	50V
C3404	ECUX1H561JCX	M	560PF J	50V
C3405	ECUX1H561JCX	M	560PF J	50V
C3406	ECUX1H561JCX	M	560PF J	50V
C3407	ECUX1H561JCX	M	560PF J	50V
C3408	ECUX1H561JCX	M	560PF J	50V
C3409	ECEA1HKA4R7	E	4.7UF	50V
C3410	ECEA1HKA100	E	10UF	50V
C3411	ECUX1H561JCX	M	560PF J	50V
C3412	ECEA1HKA4R7	E	4.7UF	50V
C3413	ECUX1H102JCX	C	1000PF J	50V
C3414	ECEA1HKA100	E	10UF	50V
C3415	ECEA1HKA100	E	10UF	50V
C3416	ECEA1HKA4R7	E	4.7UF	50V
C3417	ECEA1HKA100	E	10UF	50V
C3418	ECEA1HKA100	E	10UF	50V
C3419	ECUX1H561JCX	M	560PF J	50V
C3420	ECUX1H561JCX	M	560PF J	50V
C3421	ECUX1H561JCX	M	560PF J	50V

Ref. No	Part No.	Description				Ref. No	Part No.	Description			
C3422	ECUX1H561JCX	M	560PF	J	50V	C6765	ECA1CM221	E	220UF		16V
C3423	ECUX1H561JCX	M	560PF	J	50V	C7002	ECKF1H681KB	C	680PF	K	50V
C3424	ECUX1H561JCX	M	560PF	J	50V	C7003	ECCF1H220JC	C	22PF	J	50V
C3425	ECUX1H561JCX	M	560PF	J	50V	C7004	ECKF1H102KB	C	1000PF	K	50V
C3426	ECUX1H561JCX	M	560PF	J	50V	C7005	ECKF1H681KB	C	680PF	K	50V
C3427	ECUX1H102JCX	C	1000PF	J	50V	C7006	ECCF1H220JC	C	22PF	J	50V
C3428	ECEA1HKA4R7	E	4.7UF		50V	C7007	ECKF1H102KB	C	1000PF	K	50V
C3429	ECEA1CKA220	E	22UF		16V	C7008	ECKF1H102KB	C	1000PF	K	50V
C3430	ECEA1HKA4R7	E	4.7UF		50V	C7009	ECKF1H681KB	C	680PF	K	50V
C3431	ECEA1CN470U	E	47UF		16V	C7010	ECCF1H220JC	C	22PF	J	50V
C3432	ECJ2VF1H104Z	C	0.1UF	Z	50V	C7011	ECKF1H102KB	C	1000PF	K	50V
C3433	ECA1CM221	E	220UF		16V	C7012	ECCF1H220JC	C	22PF	J	50V
C3434	ECUX1H561JCX	M	560PF	J	50V	C7013	ECCF1H220JC	C	22PF	J	50V
C3435	ECEA1HKA100	E	10UF		50V	C7014	ECKF1H681KB	C	680PF	K	50V
C3436	ECUX1H561JCX	M	560PF	J	50V	C7015	ECKF1H681KB	C	680PF	K	50V
C3437	ECUX1H561JCX	M	560PF	J	50V	C7016	ECCF1H220JC	C	22PF	J	50V
C3438	ECEA1HKA4R7	E	4.7UF		50V	C7017	ECKF1H102KB	C	1000PF	K	50V
C3439	ECUX1H561JCX	M	560PF	J	50V	C7018	ECKF1H102KB	C	1000PF	K	50V
C3440	ECUX1H561JCX	M	560PF	J	50V	C7019	ECKF1H681KB	C	680PF	K	50V
C3441	ECEA1HKA100	E	10UF		50V	C7101	TCUY1C105KBM	C	1UF		16V
C3442	ECUX1H561JCX	M	560PF	J	50V	C7102	ECJ2VF1H103Z	C	0.01UF	Z	50V
C3443	ECUX1H561JCX	M	560PF	J	50V	C7103	ECUX1H332ZFX	C	3300PF	Z	50V
C3444	ECEA1HKA4R7	E	4.7UF		50V	C7104	ECA1CM101	E	100UF		16V
C3445	ECUX1H102JCX	C	1000PF	J	50V	C7105	ECJ2VF1H103Z	C	0.01UF	Z	50V
C3446	ECEA1HKA4R7	E	4.7UF		50V	C7106	ECJ2VF1H103Z	C	0.01UF	Z	50V
C3447	ECUX1H561JCX	M	560PF	J	50V	C7107	ECJ2VF1H103Z	C	0.01UF	Z	50V
C3460	ECUX1H561JCX	M	560PF	J	50V	C7108	ECJ2VF1H103Z	C	0.01UF	Z	50V
C3461	ECUX1H561JCX	M	560PF	J	50V	C7109	ECA1CM101	E	100UF		16V
C3496	ECUX1H561JCX	M	560PF	J	50V	C7110	ECA1CM101	E	100UF		16V
C3498	ECUX1H561JCX	M	560PF	J	50V	C7112	ECJ2VF1H103Z	C	0.01UF	Z	50V
C3802	ECA1HM100	E	10UF		50V	C7113	ECJ2VF1H103Z	C	0.01UF	Z	50V
C3803	ECA1HM100	E	10UF		50V	C7114	ECA1CM101	E	100UF		16V
C3804	ECJ2VF1H104Z	C	0.1UF	Z	50V	C7115	ECUX1H102JCX	C	1000PF	J	50V
C3805	ECUX1H224ZFX	C	0.022UF	Z	50V	C7116	ECUX1H102JCX	C	1000PF	J	50V
C3806	ECA1CM101	E	100UF		16V	C7117	ECJ2VF1H103Z	C	0.01UF	Z	50V
C3807	ECA1HHG470	E	47UF		50V	C7118	ECJ2VF1H103Z	C	0.01UF	Z	50V
C3808	ECA1VM470	E	47UF		35V	C7120	ECJ2VF1H103Z	C	0.01UF	Z	50V
C3811	ECA1HM100	E	10UF		50V	C7122	ECUX1H101JCX	C	100PF	J	50V
C3812	ECA1HM100	E	10UF		50V	C7123	ECJ2VF1H103Z	C	0.01UF	Z	50V
C3813	ECJ2VF1H104Z	C	0.1UF	Z	50V	C7124	ECUX1H101JCX	C	100PF	J	50V
C3814	ECA1HM010	E	1UF		50V	C7125	ECJ2VF1H104Z	C	0.1UF	Z	50V
C3816	ECA1CM471	E	470UF		16V	C7126	ECJ2VF1H103Z	C	0.01UF	Z	50V
C3819	ECA1HHG010	E	1UF		50V	C7127	ECJ2VF1H104Z	C	0.1UF	Z	50V
C3821	ECA1HHG010	E	1UF		50V	C7128	ECA1CM101	E	100UF		16V
C3823	ECJ2VF1H104Z	C	0.1UF	Z	50V	C7130	ECJ2VF1H103Z	C	0.01UF	Z	50V
C3824	ECUX1H103KBX	C	0.01UF	K	50V	C7131	ECA1CM101	E	100UF		16V
C3825	ECJ2VB1C224K	C	0.22UF	K	16V	C7132	ECJ2VF1H103Z	C	0.01UF	Z	50V
C3827	ECUX1H224ZFX	C	0.022UF	Z	50V	C7133	ECJ2VF1H103Z	C	0.01UF	Z	50V
C3829	ECUX1H103KBX	C	0.01UF	K	50V	C7134	ECA1CM101	E	100UF		16V
△ C6701	ECKCWS332MEB	C	3300PF	M		C7136	ECJ2VF1H103Z	C	0.01UF	Z	50V
△ C6702	ECQU2A683MN	P	0.068UF	M	250V	C7137	ECJ2VF1H103Z	C	0.01UF	Z	50V
△ C6705	ECKCWS152MEB	C	1500PF	M		C7139	ECJ2VF1H103Z	C	0.01UF	Z	50V
△ C6706	ECKCWS152MEB	C	1500PF	M		C7140	ECA1CM101	E	100UF		16V
△ C6710	ECQU2A683MN	P	0.068UF	M	250V	C7141	ECA1CM101	E	100UF		16V
C6712	ECKD3D681KBP	C	680PF	K	2KV	C7142	ECUX1H120JCX	C	12PF	J	50V
C6713	ECA2WHG3R3	E	3.3UF		450V	C7143	ECUX1H120JCX	C	12PF	J	50V
C6714	ECKD3A392KBN	C	3900PF	K	1KV	C7144	ECJ2VF1H103Z	C	0.01UF	Z	50V
C6715	ECKD3D681KBP	C	680PF	K	2KV	C7145	ECUX1H560JCX	C	56PF	J	50V
C6718	ECCD3D220KGE	C	22PF	K	2KV	C7146	ECA1CM101	E	100UF		16V
C6722	ECCD3D270KGE	C	27PF	K	2KV	C7147	ECJ2VF1H103Z	C	0.01UF	Z	50V
C6723	ECQV1H104JM	P	0.1UF	J	50V	C7148	ECUX1H471JCX	C	470PF	J	50V
C6724	ECKF1H101KB	C	100PF	K	50V	C7149	ECJ2VF1H103Z	C	0.01UF	Z	50V
△ C6729	ECKCWS471MBB	C	470PF	M		C7150	ECA1CM101	E	100UF		16V
△ C6730	ECKCWS471MBB	C	470PF	M		C7151	ECA1CM101	E	100UF		16V
C6751	ECKF1H681KB	C	680PF	K	50V	C7152	ECJ2VF1H103Z	C	0.01UF	Z	50V
C6755	ECKD2H101KB2	C	100PF	K	500V	C7153	ECA1CM101	E	100UF		16V
C6758	ECA1CHG471	E	470UF		16V	C7154	ECJ2VF1H103Z	C	0.01UF	Z	50V
C6759	ECA1HM100	E	10UF		50V	C7155	ECJ2VF1H103Z	C	0.01UF	Z	50V
C6761	ECKF1H103ZF	C	0.01UF	Z	50V	C7156	ECJ2VF1H103Z	C	0.01UF	Z	50V
C6764	ECA1CM221	E	220UF		16V	C7157	ECJ2VF1H103Z	C	0.01UF	Z	50V

Ref. No	Part No.	Description			
C7158	ECJ2VF1H103Z	C	0.01UF	Z	50V
C7159	ECJ2VF1H103Z	C	0.01UF	Z	50V
C7160	ECA1CM101	E	100UF		16V
C7161	ECA1CM101	E	100UF		16V
C7162	ECA1CM101	E	100UF		16V
C7163	ECA1CM101	E	100UF		16V
C7164	ECA1CM101	E	100UF		16V
C7165	ECA1CM101	E	100UF		16V
C7166	ECA1CM101	E	100UF		16V
C7168	ECA1CM221	E	220UF		16V
C7169	ECUX1H471JCX	C	470PF	J	50V
C7170	ECUX1H471JCX	C	470PF	J	50V
C7171	ECUX1H471JCX	C	470PF	J	50V
C7172	ECJ2VF1H103Z	C	0.01UF	Z	50V
C7173	ECUX1H471JCX	C	470PF	J	50V
C7174	ECUX1H471JCX	C	470PF	J	50V
C7175	ECUX1H471JCX	C	470PF	J	50V
C7176	ECUX1H471JCX	C	470PF	J	50V
C7177	ECUX1H471JCX	C	470PF	J	50V
C7178	ECUX1H471JCX	C	470PF	J	50V
C7179	ECUX1H471JCX	C	470PF	J	50V
C7180	ECUX1H471JCX	C	470PF	J	50V
C7181	ECUX1H471JCX	C	470PF	J	50V
C7182	ECUX1H821JCX	C	820PF	J	50V
C7183	ECA1CM221	E	220UF		16V
C7184	ECJ2VF1H103Z	C	0.01UF	Z	50V
C7185	ECUX1H821JCX	C	820PF	J	50V
C7186	ECUX1H821JCX	C	820PF	J	50V
C7187	ECUX1H821JCX	C	820PF	J	50V
C7188	ECUX1H821JCX	C	820PF	J	50V
C7189	ECUX1H821JCX	C	820PF	J	50V
C7193	ECUX1H103KBX	C	0.01UF	K	50V
C7194	ECUX1H103KBX	C	0.01UF	K	50V
C7195	ECUX1H103KBX	C	0.01UF	K	50V
C7401	ECJ2VF1H103Z	C	0.01UF	Z	50V
C7402	ECJ2VF1H103Z	C	0.01UF	Z	50V
C7403	ECJ2VF1H103Z	C	0.01UF	Z	50V
C7404	ECJ2VF1H103Z	C	0.01UF	Z	50V
C7405	ECJ2VF1H103Z	C	0.01UF	Z	50V
C7406	ECJ2VF1H103Z	C	0.01UF	Z	50V
C7407	ECUX1H101JCX	C	100PF	J	50V
C7409	ECUX1H102JCX	C	1000PF	J	50V
C7410	ECUX1H101JCX	C	100PF	J	50V
C7411	ECUX1H101JCX	C	100PF	J	50V
C7414	ECA1CM101	E	100UF		16V
C7415	ECA1CM101	E	100UF		16V
C7416	ECA1CM101	E	100UF		16V
C7417	ECA1CM101	E	100UF		16V
C7418	ECA1CM101	E	100UF		16V
C7419	ECA1CM101	E	100UF		16V
C7420	ECJ2VF1H103Z	C	0.01UF	Z	50V
C7421	ECA1CM101	E	100UF		6V
C7424	ECJ2VF1H103Z	C	0.01UF	Z	50V
C7434	ECJ2VF1H103Z	C	0.01UF	Z	50V
C7436	ECA1CM221	E	220UF		16V
C7437	ECJ2VF1H103Z	C	0.01UF	Z	50V
C7453	ECUX1H101JCX	C	100PF	J	50V
△ C7502	ECKCWS471MBB	C	470PF	M	
C7503	ECCF1H101JC	C	100PF	J	50V
C7504	ECA1HM100	E	10UF		50V
C7505	ECQB1H473JF	P	0.047UF	J	50V
C7506	ECQV1H334JM	P	0.33UF	J	50V
C7507	ECQB1H103JF	P	0.01UF	J	50V
C7511	ECQB1H821JF	P	820PF	J	50V
C7512	ECQB1H222JF	P	2200PF	J	50V
C7513	ECQV1H474JM	P	0.47UF	J	50V
C7514	ECQV1H474JM	P	0.47UF	J	50V
C7515	EEUFC1V221	E	220UF		35V
C7516	ECKF1H182KB	C	1800PF	K	50V
C7518	ECKD3D152KBP	C	1500PF	K	2KV

Ref. No	Part No.	Description			
C7519	EC0S2GP331CB	E	330UF		400V
C7520	ECKDAE472ZE	C	4700PF	Z	
C7521	ECKDAE472ZE	C	4700PF	Z	
C7522	ECKDAE472ZE	C	4700PF	Z	
C7523	ECKDAE472ZE	C	4700PF	Z	
C7524	ECQB1H222JF	P	2200PF	J	50V
C7526	ECCF1H390JC	C	39PF	J	50V
C7542	ECA1CM101	E	100UF		16V
C7543	ECA1CM101	E	100UF		16V
C7545	ECA1CM101	E	100UF		16V
C7546	ECKF1H103ZF	C	0.01UF	Z	50V
C7547	ECKF1H103ZF	C	0.01UF	Z	50V
C7548	ECKF1H103ZF	C	0.01UF	Z	50V
C7550	ECKF1H103ZF	C	0.01UF	Z	50V
C7551	ECKF1H103ZF	C	0.01UF	Z	50V
C7552	ECKF1H103ZF	C	0.01UF	Z	50V
C7553	ECA1CM101	E	100UF		16V
C7554	ECA1CM101	E	100UF		16V
C7555	ECA1CM101	E	100UF		16V
C7556	ECKF1H103ZF	C	0.01UF	Z	50V
C7557	ECKF1H103ZF	C	0.01UF	Z	50V
C7558	ECKF1H103ZF	C	0.01UF	Z	50V
C7559	ECA1HHG101	E	100UF		50V
C7560	ECA1HHG101	E	100UF		50V
C7561	ECKF1H103ZF	C	0.01UF	Z	50V
C7562	ECKF1H103ZF	C	0.01UF	Z	50V
C7563	ECA1HHG101	E	100UF		50V
C7564	ECA1HHG101	E	100UF		50V
C7565	ECKF1H103ZF	C	0.01UF	Z	50V
C7566	ECKF1H103ZF	C	0.01UF	Z	50V
C7567	ECKF1H103ZF	C	0.01UF	Z	50V
C7568	ECKF1H103ZF	C	0.01UF	Z	50V
C7570	ECQB1H103JF	P	0.01UF	J	50V
C7571	ECQB1H103JF	P	0.01UF	J	50V
C7573	ECA1VHG471	E	470UF		35V
C7574	ECA1VHG471	E	470UF		35V
C7575	ECA1VM470	E	47UF		35V
C7576	ECA1HM101	E	100UF		50V
C7577	ECA1HM100	E	10UF		50V
C7578	ECA1HM101	E	100UF		50V
C7579	ECA1VM101	E	100UF		35V
C7581	ECA1VHG332	E	3300UF		35V
C7582	ECA1VHG332	E	3300UF		35V
C7583	ECA1CHG222	E	2200UF		16V
C7584	ECA1CHG222	E	2200UF		16V
C7585	ECKD2H471KB2	C	470PF	K	500V
C7586	ECKD2H471KB2	C	470PF	K	500V
C7587	ECKD2H471KB2	C	470PF	K	500V
C7588	ECKD2H471KB2	C	470PF	K	500V
C7589	ECA1HM2R2	E	2.2UF		50V
C7701	ECJ2VF1H103Z	C	0.01UF	Z	50V
C7702	ECJ2VF1H103Z	C	0.01UF	Z	50V
C7703	ECJ2VF1H103Z	C	0.01UF	Z	50V
C7704	ECJ2VF1H103Z	C	0.01UF	Z	50V
C7705	ECUX1H391KBX	C	390PF	K	50V
C7706	ECQB1H104JF	P	0.1UF	J	50V
C7707	ECUX1H561KBX	C	560PF	K	50V
C7708	ECJ2VF1H103Z	C	0.01UF	Z	50V
C7709	ECQB1H104JF	P	0.1UF	J	50V
C7710	ECJ2VF1H103Z	C	0.01UF	Z	50V
C7711	ECJ2VF1H103Z	C	0.01UF	Z	50V
C7712	ECJ2VF1H103Z	C	0.01UF	Z	50V
C7713	ECUX1H471KBX	C	470PF	K	50V
C7714	ECJ2VF1H103Z	C	0.01UF	Z	50V
C7716	ECJ2VF1H103Z	C	0.01UF	Z	50V
C7719	ECJ2VF1H103Z	C	0.01UF	Z	50V
C7720	ECJ2VF1H103Z	C	0.01UF	Z	50V
C7721	ECJ2VF1H103Z	C	0.01UF	Z	50V
C7722	ECJ2VF1H103Z	C	0.01UF	Z	50V
C7723	ECJ2VF1H104Z	C	0.1UF	Z	50V

Ref. No	Part No.	Description	Ref. No	Part No.	Description
C7727	ECUX1H471KBX	C 470PF K 50V	C9651	ECUX1H103KBX	C 0.01UF K 50V
C7728	ECJ2VF1H103Z	C 0.01UF Z 50V		OTHERS	
C7730	ECUX1H391JXC	C 390PF J 50V	A1	TJS1A8160	PHONO PIN (10P)
C7738	ECA1HM100	E 10UF 50V	A2	TJS5A9420	8P CONNECTOR
C7751	ECA1VM470	E 47UF 35V	A3	TJS5A9420	8P CONNECTOR
			A4	TJS3A9640	3P CONNECTOR
C7752	ECA1VM470	E 47UF 35V	A5	TJS3A9650	4P CONNECTOR
C7753	ECEA1HN010U	E 1UF 50V			
C7754	ECA1VM470	E 47UF 35V	A6	TJS3A9680	7P CONNECTOR
C7755	ECA1VM470	E 47UF 35V	A7	TJSF20016	16P CONNECTOR
C7756	ECA1HM220	E 22UF 50V	A8	TJSF20016	16P CONNECTOR
			A9	TJSF20016	16P CONNECTOR
C7757	ECA1VM470	E 47UF 35V	A10	TJSF20016	16P CONNECTOR
C7758	ECA1VM470	E 47UF 35V			
C7759	ECA1HM010	E 1UF 50V	A11	TJS5A9420	8P CONNECTOR
C7760	ECA1VM470	E 47UF 35V	A12	TJS5A9420	8P CONNECTOR
C7763	ECA1HM220	E 22UF 50V	A13	TJS5A9420	8P CONNECTOR
			A14	TJS5A9420	8P CONNECTOR
C7764	ECA1VM470	E 47UF 35V	A15	TJS5A9420	8P CONNECTOR
C7766	ECA1VM470	E 47UF 35V			
C7767	ECA1HM010	E 1UF 50V	A16	TJS5A9420	8P CONNECTOR
C7768	ECA1VM470	E 47UF 35V	A17	TJS5A9420	8P CONNECTOR
C7769	ECA1VM470	E 47UF 35V	A18	TJS5A9420	8P CONNECTOR
			A19	TJS5A9420	8P CONNECTOR
C7781	ECEA1HNR22U	E 0.22UF 50V	A20	TJS5A9420	8P CONNECTOR
C7782	ECEA1HNR22U	E 0.22UF 50V			
C7783	ECEA1HNR22U	E 0.22UF 50V	A21	TJS5A9420	8P CONNECTOR
C7784	ECEA1HNR22U	E 0.22UF 50V	A23	TJS3A9650	4P CONNECTOR
C7785	ECEA1HNR22U	E 0.22UF 50V	A24	TJS3A9650	4P CONNECTOR
			A25	TJS3A9880	8P CONNECTOR
C7786	ECEA1HN010U	E 1UF 50V	A26	TJS3A9660	5P CONNECTOR
C7787	ECEA1HN010U	E 1UF 50V			
C7788	ECEA1CN100U	E 10UF 16V	A27	TJS3A9640	3P CONNECTOR
C7791	ECA1VM470	E 47UF 35V	A28	TJS3A8980	24P CONNECTOR
C7792	ECJ2VF1H103Z	C 0.01UF Z 50V	A29	TJS3A8980	24P CONNECTOR
			A31	TJS3A9640	3P CONNECTOR
C9601	ECUX1H330JXC	C 33PF J 50V	A32	TJS118590	2P CONNECTOR
C9602	ECJ2VF1H104Z	C 0.1UF Z 50V			
C9603	ECJ2VF1H104Z	C 0.1UF Z 50V	A33	TJS118590	2P CONNECTOR
C9604	ECUX1H470JXC	C 47PF J 50V	A34	TJS118590	2P CONNECTOR
C9605	ECA1CM221	E 220UF 16V	A35	TJS118590	2P CONNECTOR
			CP1	TJS5A9420	8P CONNECTOR
C9606	ECA1AM332	E 3300UF 10V	CP2	TJS5A9420	8P CONNECTOR
C9607	ECJ2VF1H104Z	C 0.1UF Z 50V			
C9608	ECJ2VF1H104Z	C 0.1UF Z 50V	CP3	TJS5A9420	8P CONNECTOR
C9609	ECA1HM4R7	E 4.7UF 50V	CP4	TJS5A9420	8P CONNECTOR
C9610	ECJ2VF1H104Z	C 0.1UF Z 50V	CP6	TJS3A9920	12P CONNECTOR
			CP7	TJS3A9650	4P CONNECTOR
C9611	ECJ2VF1H104Z	C 0.1UF Z 50V	CP11	TJS3A9650	4P CONNECTOR
C9612	ECJ2VF1H104Z	C 0.1UF Z 50V			
C9613	ECJ2VF1H104Z	C 0.1UF Z 50V	CP12	TJS3A9650	4P CONNECTOR
C9614	ECJ2VF1H104Z	C 0.1UF Z 50V	CP13	TJS3A9650	4P CONNECTOR
C9615	ECJ2VB1C104K	C 0.1UF K 16V	D2	TJS3A9660	5P CONNECTOR
			D3	TJS3A9680	7P CONNECTOR
C9616	ECQV1H104JM	P 0.1UF J 50V	D4	TJS3A9880	8P CONNECTOR
C9617	ECJ2VF1H104Z	C 0.1UF Z 50V			
C9618	ECJ2VF1H104Z	C 0.1UF Z 50V	D5	TJS158130	2P CONNECTOR
C9619	ECUX1H271JXC	C 270PF J 50V	D11	TJSF11508	8P CONNECTOR
C9620	ECUX1H100DCX	C 10PF D 50V	D12	TJSF11508	8P CONNECTOR
			D13	TJSF11508	8P CONNECTOR
C9622	ECUX1H470JXC	C 47PF J 50V	D14	TJSF11508	8P CONNECTOR
C9623	ECUX1H470JXC	C 47PF J 50V			
C9624	ECUX1H820JXC	C 82PF J 50V	D15	TJSF11508	8P CONNECTOR
C9625	ECUX1H470JXC	C 47PF J 50V	DC1	TJS5A8160	CONNECTOR
C9626	ECUX1H470JXC	C 47PF J 50V	DC2	TJS5A9450	CONNECTOR
			DC3	TJS5A9450	CONNECTOR
C9627	ECUX1H470JXC	C 47PF J 50V	DC4	TJS5A8160	CONNECTOR
C9628	ECUX1H470JXC	C 47PF J 50V			
C9632	ECJ2VF1H104Z	C 0.1UF Z 50V	DC6	TJS1A8140	PHONO PIN (8P)
C9633	ECJ2VF1H104Z	C 0.1UF Z 50V	E1	TJSF11308	8P CONNECTOR
C9635	ECA1VM101	E 100UF 35V	E2	TJSF11308	8P CONNECTOR
			E3	TJSF11308	8P CONNECTOR
C9637	ECUX1H470JXC	C 47PF J 50V	E4	TJSF11308	8P CONNECTOR
C9638	ECUX1H270JXC	C 27PF J 50V			
C9639	ECJ2VF1H104Z	C 0.1UF Z 50V	E5	TJSF11308	8P CONNECTOR
C9642	ECUX1H561JXC	M 560PF J 50V	E6	TJSF11308	8P CONNECTOR
C9643	ECJ2VF1H104Z	C 0.1UF Z 50V	E7	TJSF19916	16P CONNECTOR
			E8	TJSF19916	16P CONNECTOR
C9644	ECJ2VF1H104Z	C 0.1UF Z 50V	E9	TJSF19916	16P CONNECTOR
C9645	ECQV1H104JM	P 0.1UF J 50V			
C9646	ECUX1H103KBX	C 0.01UF K 50V	E10	TJSF19916	16P CONNECTOR
C9647	ECUX1H101JXC	C 100PF J 50V	E11	TJSF11208	8P CONNECTOR
C9649	ECUX1H103KBX	C 0.01UF K 50V			

Ref. No	Part No.	Description
E13	TJSF11208	8P CONNECTOR
E14	TJSF11208	8P CONNECTOR
E15	TJSF11208	8P CONNECTOR
E16	TJSF11208	8P CONNECTOR
F1	TJSF11508	8P CONNECTOR
F2	TJSF11508	8P CONNECTOR
F3	TJSF11508	8P CONNECTOR
F4	TJSF11508	8P CONNECTOR
F5	TJSF11508	8P CONNECTOR
F6	TJSF11508	8P CONNECTOR
F13	TJS3A9650	4P CONNECTOR
F24	TJS1A8100	PHONO PIN (4P)
F30	TJS3A9650	4P CONNECTOR
F41	TJS5A8160	CONNECTOR
F42	TJS5A9450	CONNECTOR
F43	TJS5A9450	CONNECTOR
F44	TJS5A8160	CONNECTOR
G11	TJS5A9450	CONNECTOR
G12	TJS5A9450	CONNECTOR
G13	TJS5A9450	CONNECTOR
G14	TJS5A9450	CONNECTOR
H1	TJS1A8110	TELEPHONJACK (5P)
H2	TJS1A8100	PHONO PIN (4P)
H3	TJS1A8100	PHONO PIN (4P)
H11	TJS3A8990	24P CONNECTOR
H12	TJS3A8990	24P CONNECTOR
K1	TJS3A9650	4P CONNECTOR
K2	TJS158130	2P CONNECTOR
K4	TJS3A9660	5P CONNECTOR
K11	TJS5A8160	CONNECTOR
K12	TJS3A9150	CONNECTOR
K13	TJS5A8160	CONNECTOR
LB1	TJS3A9880	8P CONNECTOR
LB2	TJS3A9640	3P CONNECTOR
LG1	TJS3A9660	5P CONNECTOR
LG2	TJS3A9650	4P CONNECTOR
LG3	TJS3A9640	3P CONNECTOR
LG4	TJS3A9880	8P CONNECTOR
LG5	TJS3A9890	9P CONNECTOR
LR1	TJS3A9890	9P CONNECTOR
LR2	TJS3A9640	3P CONNECTOR
M1	TJS169610	4P CONNECTOR
M4	TJS3A9650	4P CONNECTOR
M5	TJS3A9640	3P CONNECTOR
M11	TJS3A9660	5P CONNECTOR
M12	TJS3A9910	11P CONNECTOR
P1	TJSF45504	CONNECTOR
P2	TJS169700	5P CONNECTOR
P11	TJS3A9880	8P CONNECTOR
RM1	TJS3A9640	3P CONNECTOR
SB1	TJS3A9660	5P CONNECTOR
SG1	TJS3A9660	5P CONNECTOR
SG2	TJS3A9640	3P CONNECTOR
SG3	TJS3A9660	5P CONNECTOR
SG4	TJS3A9660	5P CONNECTOR
SR1	TJS3A9660	5P CONNECTOR
W1	TJS3A9140	CONNECTOR
W2	TJS3A9140	CONNECTOR
W3	TJS1A8150	9P CONNECTOR
W4	TJS3A9880	8P CONNECTOR
F6701-1	EYF-52BC	FUSE HOLDER
F6701-2	EYF-52BC	FUSE HOLDER
△ F6701	XBA2C50TH15	FUSE (250V5A)
J622	EXCELSA39	BEAD CHOKE
JA1	ERJ6GEY0R00	M 0 OHM J 1/10W
JA2	ERJ6GEY0R00	M 0 OHM J 1/10W
JA3	ERJ6GEY0R00	M 0 OHM J 1/10W
JA4	ERJ6GEY0R00	M 0 OHM J 1/10W
JA5	ERJ6GEY0R00	M 0 OHM J 1/10W
JA6	ERJ6GEY0R00	M 0 OHM J 1/10W

Ref. No	Part No.	Description
JA7	ERJ6GEY0R00	M 0 OHM J 1/10W
JA8	ERJ6GEY0R00	M 0 OHM J 1/10W
JA9	ERJ6GEY0R00	M 0 OHM J 1/10W
JA10	ERJ6GEY0R00	M 0 OHM J 1/10W
JA11	ERJ6GEY0R00	M 0 OHM J 1/10W
JA12	ERJ6GEY0R00	M 0 OHM J 1/10W
JA13	ERJ6GEY0R00	M 0 OHM J 1/10W
JA14	ERJ6GEY0R00	M 0 OHM J 1/10W
JA15	ERJ6GEY0R00	M 0 OHM J 1/10W
JA16	ERJ6GEY0R00	M 0 OHM J 1/10W
JA17	ERJ6GEY0R00	M 0 OHM J 1/10W
JA18	ERJ6GEY0R00	M 0 OHM J 1/10W
JA19	ERJ6GEY0R00	M 0 OHM J 1/10W
JA20	ERJ6GEY0R00	M 0 OHM J 1/10W
JA21	ERJ6GEY0R00	M 0 OHM J 1/10W
JA22	ERJ6GEY0R00	M 0 OHM J 1/10W
JA23	ERJ6GEY0R00	M 0 OHM J 1/10W
JA24	ERJ6GEY0R00	M 0 OHM J 1/10W
JA25	ERJ6GEY0R00	M 0 OHM J 1/10W
JA26	ERJ6GEY0R00	M 0 OHM J 1/10W
JA27	ERJ6GEY0R00	M 0 OHM J 1/10W
JA28	ERJ6GEY0R00	M 0 OHM J 1/10W
JA29	ERJ6GEY0R00	M 0 OHM J 1/10W
JA30	ERJ6GEY0R00	M 0 OHM J 1/10W
JA31	ERJ6GEY0R00	M 0 OHM J 1/10W
JA32	ERJ6GEY0R00	M 0 OHM J 1/10W
JA33	ERJ6GEY0R00	M 0 OHM J 1/10W
JA35	ERJ6GEY0R00	M 0 OHM J 1/10W
JA36	ERJ6GEY0R00	M 0 OHM J 1/10W
JA38	ERJ6GEY0R00	M 0 OHM J 1/10W
JA41	ERJ6GEY0R00	M 0 OHM J 1/10W
JA42	ERJ6GEY0R00	M 0 OHM J 1/10W
JA43	ERJ6GEY0R00	M 0 OHM J 1/10W
JA44	ERJ6GEY0R00	M 0 OHM J 1/10W
JA45	ERJ6GEY0R00	M 0 OHM J 1/10W
JA46	ERJ6GEY0R00	M 0 OHM J 1/10W
JA48	ERJ6GEY0R00	M 0 OHM J 1/10W
JA49	ERJ6GEY0R00	M 0 OHM J 1/10W
JA50	ERJ6GEY0R00	M 0 OHM J 1/10W
JA51	ERJ6GEY0R00	M 0 OHM J 1/10W
JA52	ERJ6GEY0R00	M 0 OHM J 1/10W
JA53	ERJ6GEY0R00	M 0 OHM J 1/10W
JA54	ERJ6GEY0R00	M 0 OHM J 1/10W
JA55	ERJ6GEY0R00	M 0 OHM J 1/10W
JA57	ERJ6GEY0R00	M 0 OHM J 1/10W
JA58	ERJ6GEY0R00	M 0 OHM J 1/10W
JA59	ERJ6GEY0R00	M 0 OHM J 1/10W
JA61	ERJ6GEY0R00	M 0 OHM J 1/10W
JA62	ERJ6GEY0R00	M 0 OHM J 1/10W
JA63	ERJ6GEY0R00	M 0 OHM J 1/10W
JA64	ERJ6GEY0R00	M 0 OHM J 1/10W
JA65	ERJ6GEY0R00	M 0 OHM J 1/10W
JA66	ERJ6GEY0R00	M 0 OHM J 1/10W
JA67	ERJ6GEY0R00	M 0 OHM J 1/10W
JA68	ERJ6GEY0R00	M 0 OHM J 1/10W
JA69	ERJ6GEY0R00	M 0 OHM J 1/10W
JA70	ERJ6GEY0R00	M 0 OHM J 1/10W
JA71	ERJ6GEY0R00	M 0 OHM J 1/10W
JC1	ERJ6GEY0R00	M 0 OHM J 1/10W
△ JK351	TJSC00700	CRT SOCKET
△ JK352	TJSC00700	CRT SOCKET
△ JK353	TJSC00700	CRT SOCKET
JK811	TJC6137	EARTH LUG
JK812	TJC6137	EARTH LUG
JK813	TJC6137	EARTH LUG
JK814	TJC6137	EARTH LUG
JK2401	TJB8E018	PIN JACK
JK2402	TJB8E015	PIN JACK
JK2403	TJB8E015	PIN JACK

Ref. No	Part No.	Description	Ref. No	Part No.	Description
JK2551	TJB18924-1	TERMINAL	JS7421	ERJ6GEYJ102	M 1KOHM J 1/10W
JK3281	TJB18613	FRONT TERMINAL	JS7423	ERJ6GEY0R00	M 0 OHM J 1/10W
JK3401	TJSF39821	21P CONNECTOR	JS7424	ERJ6GEY0R00	M 0 OHM J 1/10W
JK3402	TJSF39821	21P CONNECTOR	JS7425	ERJ6GEY0R00	M 0 OHM J 1/10W
JK3403	TJSF39821	21P CONNECTOR	JS7430	ERJ6GEY0R00	M 0 OHM J 1/10W
JS1	ERJ6GEY0R00	M 0 OHM J 1/10W	JS7431	ERJ6GEY0R00	M 0 OHM J 1/10W
JS1	EXCELSA35	BEAD CHOKE (TNPA0360AD)	JS7432	ERJ6GEY0R00	M 0 OHM J 1/10W
JS2	ERJ6GEY0R00	M 0 OHM J 1/10W	JS7433	ERJ6GEY0R00	M 0 OHM J 1/10W
JS3	EXCELSA35	BEAD CHOKE	JS7435	ERJ6GEY0R00	M 0 OHM J 1/10W
JS5	EXCELSA35	BEAD CHOKE	△ RL6701	TSEH0024	RELAY (5V)
JS6	ERJ6GEY0R00	M 0 OHM J 1/10W	△ RTL	TNAG039	F2 MODULE
JS7	ERJ6GEY0R00	M 0 OHM J 1/10W	△ RTL	TNPA0360AD	CIRCUIT BOARD LR
JS8	ERJ6GEY0R00	M 0 OHM J 1/10W	△ RTL	TNPA0361AD	CIRCUIT BOARD LG
JS9	ERJ6GEY0R00	M 0 OHM J 1/10W	△ RTL	TNPA0362AD	CIRCUIT BOARD LB
JS10	ERJ6GEY0R00	M 0 OHM J 1/10W	△ RTL	TNPA1224AB	CIRCUIT BOARD F
JS003	ERJ6GEY0R00	M 0 OHM J 1/10W	△ RTL	TNPA1226AB	CIRCUIT BOARD DC
JS004	ERJ6GEY0R00	M 0 OHM J 1/10W	△ RTL	TNPA1227AB	CIRCUIT BOARD CP
JS005	ERJ6GEY0R00	M 0 OHM J 1/10W	△ RTL	TNPA1335	CIRCUIT BOARD G
JS008	ERJ6GEY0R00	M 0 OHM J 1/10W	△ RTL	TNPA1336	CIRCUIT BOARD H
JS011	ERJ6GEY0R00	M 0 OHM J 1/10W	△ RTL	TNPA1337	CIRCUIT BOARD K
JS026	ERJ6GEY0R00	M 0 OHM J 1/10W	△ RTL	TNPA1338	CIRCUIT BOARD D
JS034	ERJ6GEY0R00	M 0 OHM J 1/10W	△ RTL	TNPA1339	CIRCUIT BOARD P
JS051	ERJ6GEY0R00	M 0 OHM J 1/10W	△ RTL	TNPA1340	CIRCUIT BOARD M
JS052	ERDS2TJ121	C 120 OHM J 1/4W	△ RTL	TNPA1341	CIRCUIT BOARD K2
JSF001	ERJ6GEY0R00	M 0 OHM J 1/10W	△ RTL	TNPA1342	CIRCUIT BOARD RM
JSF005	ERJ6GEY0R00	M 0 OHM J 1/10W	△ RTL	TNPA1405	CIRCUIT BOARD SG
JSF006	ERJ6GEY0R00	M 0 OHM J 1/10W	△ RTL	TNPA1406	CIRCUIT BOARD SR
JSF007	ERJ6GEY0R00	M 0 OHM J 1/10W	△ RTL	TNPA1408	CIRCUIT BOARD SB
JSF009	ERJ6GEY0R00	M 0 OHM J 1/10W	△ RTL	TNPA1431	CIRCUIT BOARD W
JSF010	ERJ6GEY0R00	M 0 OHM J 1/10W	△ RTL	TNPH0243AB	CIRCUIT BOARD E
JSF013	ERJ6GEY0R00	M 0 OHM J 1/10W	△ RTL	TNPH0264	CIRCUIT BOARD A
JSF015	ERJ6GEY0R00	M 0 OHM J 1/10W	△ S840	ESB92S11B	SWITCH
JSF017	ERJ6GEY0R00	M 0 OHM J 1/10W	S1701	EVQK06K	SWITCH
JSF018	ERJ6GEY0R00	M 0 OHM J 1/10W	S1702	EVQK06K	SWITCH
JSF019	ERJ6GEY0R00	M 0 OHM J 1/10W	S1703	EVQK06K	SWITCH
JSF020	ERJ6GEY0R00	M 0 OHM J 1/10W	S1704	EVQK06K	SWITCH
JSF021	ERJ6GEY0R00	M 0 OHM J 1/10W	S1705	EVQK06K	SWITCH
JSF022	ERJ6GEY0R00	M 0 OHM J 1/10W	S2401	TSE8E001	SLIDE SWITCH
JSF023	ERJ6GEY0R00	M 0 OHM J 1/10W	X101	EFC56504BF	CERAMIC FILTER
JSF024	ERJ6GEY0R00	M 0 OHM J 1/10W	X102	EFC57004BF	CERAMIC FILTER
JSF025	ERJ6GEY0R00	M 0 OHM J 1/10W	X501	TAFCSB503F38	CERAMIC RESONATOR
JSF026	ERJ6GEY0R00	M 0 OHM J 1/10W	X1101	TSSA121	CRYSTAL
JSF027	ERJ6GEY0R00	M 0 OHM J 1/10W	X1501	TSS2169-B	CRYSTAL
JSF028	ERJ6GEY0R00	M 0 OHM J 1/10W	X1801	TSSA009	CRYSTAL
JSF029	ERJ6GEY0R00	M 0 OHM J 1/10W	X1802	TSSA025	CRYSTAL
JSF032	ERJ6GEY0R00	M 0 OHM J 1/10W	X1803	TSSA024	CRYSTAL
JSF034	ERJ6GEY0R00	M 0 OHM J 1/10W	X2101	TSSA074	CRYSTAL
JSF037	ERJ6GEY0R00	M 0 OHM J 1/10W	X2501	TSSA074	CRYSTAL
JSF039	ERJ6GEY0R00	M 0 OHM J 1/10W	X7101	EF0EC4004A4	CERAMIC FILTER
JSF041	ERJ6GEY0R00	M 0 OHM J 1/10W	X9601	TSSA010	CRYSTAL
JSF042	ERJ6GEY0R00	M 0 OHM J 1/10W			
JSF043	ERJ6GEY0R00	M 0 OHM J 1/10W			
JSG1	ERJ6GEY0R00	M 0 OHM J 1/10W			
JSG2	ERJ6GEY0R00	M 0 OHM J 1/10W			
JSG3	ERJ6GEY0R00	M 0 OHM J 1/10W			
JSG4	ERJ6GEY0R00	M 0 OHM J 1/10W			
JSG9	ERJ6GEY0R00	M 0 OHM J 1/10W			
JSG10	ERJ6GEY0R00	M 0 OHM J 1/10W			
JSG13	ERJ6GEY0R00	M 0 OHM J 1/10W			
JSG14	ERJ6GEY0R00	M 0 OHM J 1/10W			
JSH002	ERJ6GEY0R00	M 0 OHM J 1/10W			
JSH009	ERJ6GEY0R00	M 0 OHM J 1/10W			
JSK021	ERJ6GEY0R00	M 0 OHM J 1/10W			
JS7413	ERJ6GEY0R00	M 0 OHM J 1/10W			
JS7414	ERJ6GEY0R00	M 0 OHM J 1/10W			
JS7415	ERJ6GEY0R00	M 0 OHM J 1/10W			
JS7416	ERJ6GEY0R00	M 0 OHM J 1/10W			
JS7417	ERJ6GEY0R00	M 0 OHM J 1/10W			
JS7418	ERJ6GEY0R00	M 0 OHM J 1/10W			
JS7419	ERJ6GEY0R00	M 0 OHM J 1/10W			